

TECHNOLOGICAL UNIVERSITY OF THE PHILIPPINES – CAVITE
CQT Ave., Brgy. Salawag, City of Dasmariñas, Cavite

BUDGET PROPOSAL

(Regular Fund 01)

FY 2027



TECHNOLOGICAL UNIVERSITY OF THE PHILIPPINES CAVITE

CQT Avenue, Brgy. Salawag, City of Dasmariñas, Cavite

EXECUTIVE BRIEF

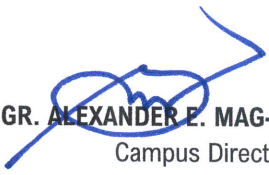
SUBJECT	REQUEST FOR APPROVAL OF THE FY 2027 BUDGET PROPOSAL FOR TIER I AND TIER II UNDER REGULAR AGENCY FUND 01																				
SOURCE OF FUND	REGULAR AGENCY FUND 01																				
BACKGROUND	<p>The FY 2027 Budget Proposal for Tier I and Tier II under the Regular Agency Fund 01 has been prepared in alignment with the operational requirements of TUP Cavite. This proposal is designed to ensure the efficient allocation of resources necessary for sustaining and enhancing the institution's academic, research, extension, and administrative functions.</p> <p>Tier I (Ongoing Programs and Activities) covers the baseline requirements of TUP Cavite, ensuring the continued implementation of personnel services and existing programs that are essential in maintaining institutional stability and compliance with government regulations.</p> <p>Tier II (Proposed New Programs) includes the budgetary requests for new initiatives and critical enhancements to existing services. These proposals aim to support institutional development priorities and infrastructure improvements of TUP Cavite.</p> <p>This proposal is crucial to sustaining campus operations, improving service delivery, and advancing academic excellence for FY 2027 and the amount is enumerated hereunder:</p> <table border="1"> <thead> <tr> <th></th> <th>TIER I</th> <th>TIER II</th> <th>TOTAL BUDGET PROPOSAL</th> </tr> </thead> <tbody> <tr> <td>PERSONNEL SERVICES</td> <td>101,701,219.00</td> <td>9,977,026.00</td> <td>111,678,245.00</td> </tr> <tr> <td>MOOE</td> <td>15,801,203.00</td> <td>6,970,665.00</td> <td>22,771,868.00</td> </tr> <tr> <td>CAPITAL OUTLAY</td> <td>-</td> <td>211,000,000.00</td> <td>211,000,000.00</td> </tr> <tr> <td>GRAND TOTAL</td> <td>117,502,422.00</td> <td>227,947,691.00</td> <td>345,450,113.00</td> </tr> </tbody> </table>		TIER I	TIER II	TOTAL BUDGET PROPOSAL	PERSONNEL SERVICES	101,701,219.00	9,977,026.00	111,678,245.00	MOOE	15,801,203.00	6,970,665.00	22,771,868.00	CAPITAL OUTLAY	-	211,000,000.00	211,000,000.00	GRAND TOTAL	117,502,422.00	227,947,691.00	345,450,113.00
	TIER I	TIER II	TOTAL BUDGET PROPOSAL																		
PERSONNEL SERVICES	101,701,219.00	9,977,026.00	111,678,245.00																		
MOOE	15,801,203.00	6,970,665.00	22,771,868.00																		
CAPITAL OUTLAY	-	211,000,000.00	211,000,000.00																		
GRAND TOTAL	117,502,422.00	227,947,691.00	345,450,113.00																		
LEGAL BASIS	National Budget Memorandum No. 156 dated January 05, 2026																				
RECOMMENDATION	For the Confirmation/Approval of the BOARD OF REGENTS																				
CERTIFICATION	The undersigned hereby certify to the accuracy and completeness of all attached documents.																				
<p style="text-align: right;">  ATTY. DANILO M. ABAYON Chief Administrative Officer/ADAF </p> <p>Recommending Approval:</p> <p style="text-align: center;">  ENGR. ALEXANDER E. MAG-ISA, PhD.,PME Campus Director </p>																					



TUP-Cavite Administrative Council
Resolution No. 01, s. 2026

RESOLUTION ENDORSING THE APPROVAL OF FY 2027 BUDGET PROPOSAL FOR TIER I AND TIER II UNDER REGULAR AGENCY FUND 01

WHEREAS:

1. Technological University of the Philippines (TUP) Cavite Campus is committed to sustaining and enhancing its academic, research, extension, and administrative functions to fulfill its institutional mandate;
2. TUPC has prepared a comprehensive Fiscal Year (FY) 2027 Budget Proposal under Regular Agency Fund 01, encompassing Tier I (Ongoing Programs and Activities) and Tier II (Proposed New Programs) and recommends the approval of the said proposal and should pass through the Administrative Council before being recommended to the Board of Regents (BOR) Finance Committee for endorsement;
3. In the meeting held on March 05, 2026, the proposal was presented by Ms. Nikki Rose C. Vergara, Budget officer, to the administrative council;
4. The total proposed budget is Php 345,450,113.00, with Php 117,502,422.00 allocated for Tier I and Php 227,947,691.00 allocated for Tier II, designed to support institutional development priorities and infrastructure improvements;
5. In the same meeting, the members of the Administrative Council at Cavite Campus unanimously agreed to endorse the FY 2027 Budget Proposal for Regular Fund 01 for the approval of the Board of Regents (BOR).

NOW, THEREFORE, BE IT RESOLVED, as it is hereby resolved, that the proposal for approval of FY 2027 Budget Proposal for Regular Fund 01, and be endorsed for approval to the board of regents through the BOR finance committee.

APPROVED.

Done this 5th of March 2026.

Certified Correct:

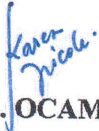
KAREN NICOLE OCAMPO
Campus Secretary

Attested:

ENGR. ALEXANDER E. MAG-ISA, Ph.D., PME
Campus Director

Approved:

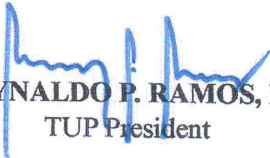
ENGR. REYNALDO P. RAMOS, Ph.D., EnP
TUP President



TECHNOLOGICAL UNIVERSITY OF THE PHILIPPINES
CAVITE CAMPUS

DETAILS OF FY 2027 BUDGET PROPOSAL

UACS Code	OBJECT OF EXPENDITURES	TIER 1	TIER 2	TOTAL	REMARKS
	PERSONAL SERVICES				
5-01-01-010-01	Basic Salary- Civilian	43,884,504	-	43,884,504	
5-01-01-020-00	Salaries & Wages-Casuals	1,926,413	-	1,926,413	
5-01-02-010-01	PERA- Civilian	1,800,000	-	1,800,000	
5-01-02-020-00	Representation Allowance	72,000	-	72,000	
5-01-02-030-01	Transportation Allowance	72,000	-	72,000	
5-01-02-040-01	Clothing Allowance	525,000	-	525,000	
5-01-02-100-01	Honoraria	2,076,000	7,079,055	9,155,055	Overload of Faculty
5-01-02-130-00	Overtime Pay	-	2,897,971	2,897,971	Overtime Services for Admin
5-01-02-140-01	Year End Benefits	3,657,042	-	3,657,042	
5-01-02-150-01	Cash Gift	375,000	-	375,000	
5-01-02-990-12	Productivity Enhancement Incentive	375,000	-	375,000	
5-01-02-990-36	Mid-Year Bonus	3,657,042	-	3,657,042	
5-01-03-020-01	PAG-IBIG Contributions	180,000	-	180,000	
5-01-03-030-01	PHILHEALTH Contributions	1,042,233	-	1,042,233	
5-01-03-040-01	ECIP Contributions	90,000	-	90,000	
5-01-04-030-01	Terminal Leave Benefits	787,798	-	787,798	
5-01-04-990-10	Lump-sum for Step Increments-Length of service	101,000	-	101,000	
5-01-04-990-07	Lump-sum for Vacant Positions	35,249,046	-	35,249,046	
5-01-04-990-15	Loyalty Award - Civilian	40,000	-	40,000	
	Other Personnel Benefits (Anniversary Bonus)	-	-	-	
	Other Personnel Benefits (Medical Allowance)	525,000	-	525,000	
	Sub-total	96,435,078	9,977,026	106,412,104	



TECHNOLOGICAL UNIVERSITY OF THE PHILIPPINES
CAVITE CAMPUS

DETAILS OF FY 2027 BUDGET PROPOSAL

UACS Code	OBJECT OF EXPENDITURES	TIER 1	TIER 2	TOTAL	REMARKS
	PERSONAL SERVICES				
5-01-03-010-00	Life & Retirement Insurance Contribution	5,266,141	-	5,266,141	
	SUB-TOTAL, PS	101,701,219	9,977,026	111,678,245	
	M.O.O.E.				
5-02-01-010-00	Traveling Expense- Local	642,000	-	642,000	
5-02-01-020-00	Traveling Expense- Foreign	137,000	-	137,000	
5-02-02-010-02	Training Expenses	523,000	-	523,000	
5-02-03-010-02	Office Supplies Expenses	981,000	-	981,000	
5-02-03-020-00	Accountable Forms	27,000	-	27,000	
5-02-03-090-00	Fuel, Oil and Lubricants Expenses	95,000	-	95,000	
5-02-03-110-01	Textbooks & Instructional Materials Expenses	350,000	-	350,000	
5-02-03-990-00	Other Supplies Expenses	733,000	-	733,000	
5-02-04-010-00	Water Expenses	612,000	-	612,000	
5-02-04-020-00	Electricity Expenses	3,687,203	-	3,687,203	
5-02-05-010-00	Postage and Courier	44,000	-	44,000	
5-02-05-020-02	Telephone Expenses-Landline	180,000	-	180,000	
5-02-05-020-01	Telephone Expenses-Mobile	37,000	17,000	54,000	Increase of communication expenses (Budget Circular 2024-2)
5-02-05-030-00	Internet Expenses	38,000	-	38,000	
5-02-99-030-00	Representation Expenses	653,000	-	653,000	
5-02-99-050-04	Rent - Equipment	240,000	-	240,000	
5-02-11-020-00	Auditing Services	10,000	-	10,000	
5-02-12-020-00	Janitorial Services	2,600,000	2,550,709	5,150,709	1 year contract for Janitorial Services
5-02-12-030-00	Security Services	3,800,000	3,402,956	7,202,956	1 year contract for Security Services



**TECHNOLOGICAL UNIVERSITY OF THE PHILIPPINES
CAVITE CAMPUS**

DETAILS OF FY 2027 BUDGET PROPOSAL

UACS Code	OBJECT OF EXPENDITURES	TIER 1	TIER 2	TOTAL	REMARKS
	M.O.O.E.				
5-02-13-040-01	Repair and Maintenance- Building	150,000	-	150,000	
5-02-13-040-02	Repair and Maintenance-School Bldg.	-	-	-	
5-02-13-040-07	Repair and Maintenance-Other Structures	-	-	-	
5-02-13-060-01	Repair and Maintenance-Office Equipment	-	-	-	
5-02-13-060-01	Repair and Maintenance-Motor Vehicle	100,000	-	100,000	
5-02-10-030-00	Extraordinary & Miscellaneous Expenses	102,000	-	102,000	
5-02-15-020-00	Fidelity Bond Premium	60,000	-	60,000	
5-02-15-030-00	Insurance Expenses	-	1,000,000	1,000,000	Insurance of facilities and equipment
	SUB-TOTAL, MOOE	15,801,203	6,970,665	22,771,868	
	CAPITAL OUTLAYS				
	Construction of Campus Dormitory at TUP-Cavite (Phase II)	-	75,000,000	75,000,000	
	Acquisition of Mini Steam Power Plant/Boiler for BSME program	-	15,000,000	15,000,000	
	Construction of Boiler Room at TUP Cavite Campus	-	10,000,000	10,000,000	
	Construction of Architecture and Engineering Building at TUP Cavite Campus (Phase I)	-	77,500,000	77,500,000	
	Renovation of Gymnasium at TUP Cavite Campus	-	30,000,000	30,000,000	
	Acquisition of 1 Unit Electric PUV under Green Public Procurement for Sustainable and Equitable Campus Mobility	-	3,500,000	3,500,000	
	SUB-TOTAL, CO	-	211,000,000	211,000,000	



TECHNOLOGICAL UNIVERSITY OF THE PHILIPPINES
CAVITE CAMPUS

DETAILS OF FY 2027 BUDGET PROPOSAL

UACS Code	OBJECT OF EXPENDITURES	TIER 1	TIER 2	TOTAL	REMARKS
	TOTAL	117,502,422	227,947,691	345,450,113	

Prepared by:

NIKKI ROSE C. VERGARA
Budget Officer III

Noted by:

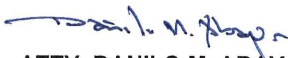
ATTY. DANILO M. ABAYON
Chief Administrative Officer/ADAF

Approved by:

ENGR. ALEXANDER E. MAG-ISA, PhD.,PME
Campus Director

**BP FORM 201 - SUMMARY OF OBLIGATIONS
AND PROPOSED ACTIVITIES / PROJECTS
(In Thousand Pesos)**

Department : State Universities and Colleges (SUCs)
 Agency : Technological University of the Philippines
 Operating Unit : Technological University of the Philippines - Cavite
 Authorization : New General Appropriations

UACS Code(s)	Cost Structure/Programs/ Activities/Projects	2025 - ACTUAL OBLIGATION					2026 - GAA					2027 - PROPOSED PROGRAM														
		PS	MOOE	FinEx	CO	TOTAL	PS	MOOE	FinEx	CO	TOTAL	TIER 1					TIER 2					TOTAL PROPOSED PROGRAM				
												PS	MOOE	FinEx	CO	TOTAL	PS	MOOE	FinEx	CO	TOTAL	PS	MOOE	FinEx	CO	TOTAL
(1)	(2)	(3)	(4)	(5)	(6)	(7)	(8)	(9)	(10)	(11)	(12)	(13)	(14)	(15)	(16)	(17)	(18)	(19)	(20)	(21)	(22)	(23)	(24)	(25)	(26)	(27)
1000000000000000	General Administration and Support	13,806	8,781	0	0	22,587	39,570	10,156	0	0	49,726	14,390	10,870	0	0	25,260	38,147	6,971	0	0	45,118	52,537	17,841	0	0	70,378
100000100001000	General Management and Supervision	11,369	8,781	0	0	20,150	11,777	10,156	0	0	21,933	13,602	10,870	0	0	24,472	2,898	6,971	0	0	9,869	16,500	17,841	0	0	34,341
100000100002000	Administration of Personnel Benefits	2,437	0	0	0	2,437	27,793	0	0	0	27,793	788	0	0	0	788	35,249	0	0	0	35,249	36,037	0	0	0	36,037
2000000000000000	Support to Operations	0	259	0	0	259	0	274	0	0	274	0	279	0	0	279	0	0	0	0	0	0	279	0	0	279
200000100001000	Auxiliary Services	0	259	0	0	259	0	274	0	0	274	0	279	0	0	279	0	0	0	0	0	0	279	0	0	279
3000000000000000	Operations	43,488	3,739	0	867	48,094	48,044	5,007	0	0	53,051	46,804	3,884	0	0	50,688	7,079	0	0	211,000	218,079	53,883	3,884	0	211,000	268,767
3100000000000000	OO : Relevant and quality tertiary education ensured to achieve inclusive growth and access of poor but deserving students to quality tertiary education increased	43,488	3,222	0	867	47,577	48,044	4,407	0	0	52,451	46,804	3,310	0	0	50,114	7,079	0	0	211,000	218,079	53,883	3,310	0	211,000	268,193
3101000000000000	HIGHER EDUCATION PROGRAM	43,488	3,222	0	867	47,577	48,044	4,407	0	0	52,451	46,804	3,310	0	0	50,114	7,079	0	0	211,000	218,079	53,883	3,310	0	211,000	268,193
	Project(s)	0	0	0	0	0	0	0	0	0	0	0	0	0	0	0	0	0	0	211,000	211,000	0	0	0	211,000	211,000
	Locally-Funded Project(s)	0	0	0	0	0	0	0	0	0	0	0	0	0	0	0	0	0	0	211,000	211,000	0	0	0	211,000	211,000
310100200027000	Construction of Campus Dormitory at TUP Cavite (Phase II)	0	0	0	0	0	0	0	0	0	0	0	0	0	0	0	0	0	0	75,000	75,000	0	0	0	75,000	75,000
310100200030000	Construction of Architecture and Engineering Building at TUP Cavite Campus (Phase I)	0	0	0	0	0	0	0	0	0	0	0	0	0	0	0	0	0	0	77,500	77,500	0	0	0	77,500	77,500

Department : State Universities and Colleges (SUCs)
 Agency : Technological University of the Philippines
 Operating Unit : Technological University of the Philippines - Cavite
 Authorization : New General Appropriations

UACS Code(s)	Cost Structure/Programs/ Activities/Projects	2025 - ACTUAL OBLIGATION					2026 - GAA					2027 - PROPOSED PROGRAM														
		PS	MOOE	FinEx	CO	TOTAL	PS	MOOE	FinEx	CO	TOTAL	TIER 1					TIER 2					TOTAL PROPOSED PROGRAM				
												PS	MOOE	FinEx	CO	TOTAL	PS	MOOE	FinEx	CO	TOTAL	PS	MOOE	FinEx	CO	TOTAL
(1)	(2)	(3)	(4)	(5)	(6)	(7)	(8)	(9)	(10)	(11)	(12)	(13)	(14)	(15)	(16)	(17)	(18)	(19)	(20)	(21)	(22)	(23)	(24)	(25)	(26)	(27)
310100200031000	Renovation of Gymnasium at TUP Cavite Campus	0	0	0	0	0	0	0	0	0	0	0	0	0	0	0	0	0	0	30,000	30,000	0	0	0	30,000	30,000
310100200032000	Acquisition of One (1) Unit Electric PUV under Green Public Procurement for Sustainable and Equitable Campus Mobility	0	0	0	0	0	0	0	0	0	0	0	0	0	0	0	0	0	0	3,500	3,500	0	0	0	3,500	3,500
310100200033000	Acquisition of Mini Steam Power Plant/Boiler for BSME Program and Construction of Boiler Room at TUP Cavite Campus	0	0	0	0	0	0	0	0	0	0	0	0	0	0	0	0	0	0	25,000	25,000	0	0	0	25,000	25,000
310100100001000	Provision of Higher Education Services	43,488	3,222	0	867	47,577	48,044	4,407	0	0	52,451	46,804	3,310	0	0	50,114	7,079	0	0	7,079	53,883	3,310	0	0	57,193	
320000000000000	OO : Higher education research improved to promote economic productivity and innovation	0	330	0	0	330	0	374	0	0	374	0	381	0	0	381	0	0	0	0	0	381	0	0	381	
320200000000000	RESEARCH PROGRAM	0	330	0	0	330	0	374	0	0	374	0	381	0	0	381	0	0	0	0	0	381	0	0	381	
320200100001000	Conduct of Research Services	0	330	0	0	330	0	374	0	0	374	0	381	0	0	381	0	0	0	0	0	381	0	0	381	
330000000000000	OO : Community engagement increased	0	187	0	0	187	0	226	0	0	226	0	193	0	0	193	0	0	0	0	0	193	0	0	193	
330100000000000	TECHNICAL ADVISORY EXTENSION PROGRAM	0	187	0	0	187	0	226	0	0	226	0	193	0	0	193	0	0	0	0	0	193	0	0	193	
330100100001000	Provision of Extension Services	0	187	0	0	187	0	226	0	0	226	0	193	0	0	193	0	0	0	0	0	193	0	0	193	
GRAND TOTAL		57,294	12,779	0	867	70,940	87,614	15,437	0	0	103,051	61,194	15,033	0	0	76,227	45,226	6,971	0	211,000	263,197	106,420	22,004	0	211,000	339,424

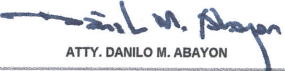
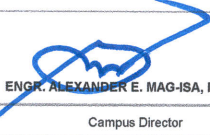
Prepared by:  NIKKI ROSE C. VERGARA Budget Officer III	Certified Correct:  ATTY. DANILO M. ABAYON Asst. Director for Admin and Finance	Approved by:  ENGR. ALEXANDER E. MAG-ISA, PH.D.,PME Campus Director	Date: _____ DAY/MO/YEAR
--	--	---	-------------------------------

BP Form 201 - Agency Request - PS
(In Thousand Pesos)

Department : State Universities and Colleges (SUCs)
 Agency : Technological University of the Philippines
 Operating Unit : Technological University of the Philippines - Cavite
 Authorization :

Tier 1



UACS Code(s)	Cost Structure/Programs/ Activities/Projects	Salaries and Wages - Regular	Salaries and Wages - Casual/Contractual	Personal Economic Relief Allowance (PERA)	Representation Allowance (RA)	Transportation Allowance (TA)	Clothing/Uniform Allowance	Honoraria	Overtime and Night Pay	Year End Bonus	Cash Gift	Mid-Year Bonus - Civilian	Other Bonuses and Allowances		Pag-IBIG Contributions	PhilHealth Contributions	Employees Compensation Insurance Premiums (ECIP)	Terminal Leave Benefits	Other Personnel Benefits			TOTAL
		Basic Salary - Civilian		PERA - Civilian		Transportation Allowance (TA)	Clothing/Uniform Allowance - Civilian	Honoraria - Civilian	Overtime Pay	Bonus - Civilian	Cash Gift - Civilian	Mid-Year Bonus - Civilian	Productivity Enhancement Incentive - Civilian	Medical Allowance	Pag-IBIG - Civilian	PhilHealth - Civilian	ECIP - Civilian	Terminal Leave Benefits - Civilian	Lump-sum for Filling of Positions - Civilian	Lump-sum for Step Increments - Length of Service	Loyalty Award - Civilian	
10000000000000	General Administration and Support	7,835	1,926	384	72	72	112	900	0	653	80	653	80	525	38	193	19	788	0	20	40	14,390
100000100001000	General Management and Supervision	7,835	1,926	384	72	72	112	900	0	653	80	653	80	525	38	193	19	0	0	20	40	13,602
100000100002000	Administration of Personnel Benefits	0	0	0	0	0	0	0	0	0	0	0	0	0	0	0	0	788	0	0	0	788
300000000000000	Operations	36,049	0	1,416	0	0	413	1,176	0	3,004	295	3,004	295	0	142	849	71	0	0	90	0	46,804
310000000000000	OO : Relevant and quality tertiary education ensured to achieve inclusive growth and access of poor but deserving students to quality tertiary education increased	36,049	0	1,416	0	0	413	1,176	0	3,004	295	3,004	295	0	142	849	71	0	0	90	0	46,804
310100000000000	HIGHER EDUCATION PROGRAM	36,049	0	1,416	0	0	413	1,176	0	3,004	295	3,004	295	0	142	849	71	0	0	90	0	46,804
310100100001000	Provision of Higher Education Services	36,049	0	1,416	0	0	413	1,176	0	3,004	295	3,004	295	0	142	849	71	0	0	90	0	46,804
Grand Total		43,884	1,926	1,800	72	72	525	2,076	0	3,657	375	3,657	375	525	180	1,042	90	788	0	110	40	61,194

Tier 2

UACS Code(s)	Cost Structure/Programs/ Activities/Projects	Salaries and Wages - Regular	Salaries and Wages - Casual/Contractual	Personal Economic Relief Allowance (PERA)	Representation Allowance (RA)	Transportation Allowance (TA)	Clothing/Uniform Allowance	Honoraria	Overtime and Night Pay	Year End Bonus	Cash Gift	Mid-Year Bonus - Civilian	Other Bonuses and Allowances		Pag-IBIG Contributions	PhilHealth Contributions	Employees Compensation Insurance Premiums (ECIP)	Terminal Leave Benefits	Other Personnel Benefits			TOTAL	
		Basic Salary - Civilian		PERA - Civilian		Transportation Allowance (TA)	Clothing/Uniform Allowance - Civilian	Honoraria - Civilian	Overtime Pay	Bonus - Civilian	Cash Gift - Civilian	Mid-Year Bonus - Civilian	Productivity Enhancement Incentive - Civilian	Medical Allowance	Pag-IBIG - Civilian	PhilHealth - Civilian	ECIP - Civilian	Terminal Leave Benefits - Civilian	Lump-sum for Filling of Positions - Civilian	Lump-sum for Step Increments - Length of Service	Loyalty Award - Civilian		
100000000000000	General Administration and Support	0	0	0	0	0	0	0	2,898	0	0	0	0	0	0	0	0	0	0	35,249	0	0	38,147
100000100001000	General Management and Supervision	0	0	0	0	0	0	0	2,898	0	0	0	0	0	0	0	0	0	0	0	0	0	2,898
100000100002000	Administration of Personnel Benefits	0	0	0	0	0	0	0	0	0	0	0	0	0	0	0	0	0	0	0	0	0	0
300000000000000	Operations	0	0	0	0	0	0	7,079	0	0	0	0	0	0	0	0	0	0	0	35,249	0	0	35,249
310000000000000	OO : Relevant and quality tertiary education ensured to achieve inclusive growth and access of poor but deserving students to quality tertiary education increased	0	0	0	0	0	0	7,079	0	0	0	0	0	0	0	0	0	0	0	0	0	0	7,079
310100000000000	HIGHER EDUCATION PROGRAM	0	0	0	0	0	0	7,079	0	0	0	0	0	0	0	0	0	0	0	0	0	0	7,079
310100100001000	Provision of Higher Education Services	0	0	0	0	0	0	7,079	0	0	0	0	0	0	0	0	0	0	0	0	0	0	7,079
Grand Total		0	0	0	0	0	0	7,079	2,898	0	0	0	0	0	0	0	0	0	0	35,249	0	0	45,226

Total

UACS Code(s)	Cost Structure/Programs/ Activities/Projects	Salaries and Wages - Regular	Salaries and Wages - Casual/Contractual	Personal Economic Relief Allowance (PERA)	Representation Allowance (RA)	Transportation Allowance (TA)	Clothing/Uniform Allowance	Honoraria	Overtime and Night Pay	Year End Bonus	Cash Gift	Mid-Year Bonus - Civilian	Other Bonuses and Allowances		Pag-IBIG Contributions	PhilHealth Contributions	Employees Compensation Insurance Premiums (ECIP)	Terminal Leave Benefits	Other Personnel Benefits			TOTAL
		Basic Salary - Civilian		PERA - Civilian		Transportation Allowance (TA)	Clothing/Uniform Allowance - Civilian	Honoraria - Civilian	Overtime Pay	Bonus - Civilian	Cash Gift - Civilian	Mid-Year Bonus - Civilian	Productivity Enhancement Incentive - Civilian	Medical Allowance	Pag-IBIG - Civilian	PhilHealth - Civilian	ECIP - Civilian	Terminal Leave Benefits - Civilian	Lump-sum for Filling of Positions - Civilian	Lump-sum for Step Increments - Length of Service	Loyalty Award - Civilian	
1000000000000000	General Administration and Support	7,835	1,926	384	72	72	112	900	2,898	653	80	653	80	525	38	193	19	788	35,249	20	40	52,537
100000100001000	General Management and Supervision	7,835	1,926	384	72	72	112	900	2,898	653	80	653	80	525	38	193	19	0	0	20	40	16,500
100000100002000	Administration of Personnel Benefits	0	0	0	0	0	0	0	0	0	0	0	0	0	0	0	0	788	35,249	0	0	36,037
3000000000000000	Operations	36,049	0	1,416	0	0	413	8,255	0	3,004	295	3,004	295	0	142	849	71	0	0	90	0	53,883
3100000000000000	OO : Relevant and quality tertiary education ensured to achieve inclusive growth and access of poor but deserving students to quality tertiary education increased	36,049	0	1,416	0	0	413	8,255	0	3,004	295	3,004	295	0	142	849	71	0	0	90	0	53,883
3101000000000000	HIGHER EDUCATION PROGRAM	36,049	0	1,416	0	0	413	8,255	0	3,004	295	3,004	295	0	142	849	71	0	0	90	0	53,883
310100100001000	Provision of Higher Education Services	36,049	0	1,416	0	0	413	8,255	0	3,004	295	3,004	295	0	142	849	71	0	0	90	0	53,883
Grand Total		43,884	1,926	1,800	72	72	525	9,155	2,898	3,657	375	3,657	375	525	180	1,042	90	788	35,249	110	40	106,420

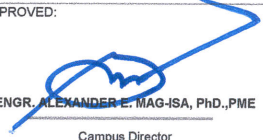
PREPARED BY:  NIKKI ROSE C. VERGARA Budget Officer III	CERTIFIED CORRECT:  ATTY. DANILO M. ABAYON Asst. Director for Admin and Finance	APPROVED:  ENGR. ALEXANDER E. MAG-ISA, Ph.D., PME Campus Director	DATE: DAY/MO/YEAR
--	---	--	--------------------------

BP Form 201 - Agency Request - PS
(In Thousand Pesos)

Department : State Universities and Colleges (SUCs)
Agency : Technological University of the Philippines
Operating Unit : Technological University of the Philippines - Cavite
Authorization :

Tier 1



UACS Code(s)	Cost Structure/Programs/ Activities/Projects	Retirement and Life Insurance Premiums	TOTAL
10000000000000	General Administration and Support	940	940
100000100001000	General Management and Supervision	940	940
300000000000000	Operations	4,326	4,326
310000000000000	OO : Relevant and quality tertiary education ensured to achieve inclusive growth and access of poor but deserving students to quality tertiary education increased	4,326	4,326
310100000000000	HIGHER EDUCATION PROGRAM	4,326	4,326
310100100001000	Provision of Higher Education Services	4,326	4,326
Grand Total		5,266	5,266

Tier 2



UACS Code(s)	Cost Structure/Programs/ Activities/Projects	Retirement and Life Insurance Premiums	TOTAL
100000000000000	General Administration and Support	0	0
100000100001000	General Management and Supervision	0	0
300000000000000	Operations	0	0
310000000000000	OO : Relevant and quality tertiary education ensured to achieve inclusive growth and access of poor but deserving students to quality tertiary education increased	0	0
310100000000000	HIGHER EDUCATION PROGRAM	0	0
310100100001000	Provision of Higher Education Services	0	0
Grand Total		0	0

Total

UACS Code(s)	Cost Structure/Programs/ Activities/Projects	Retirement and Life Insurance Premiums	TOTAL
1000000000000000	General Administration and Support	940	940
100000100001000	General Management and Supervision	940	940
3000000000000000	Operations	4,326	4,326
3100000000000000	OO : Relevant and quality tertiary education ensured to achieve inclusive growth and access of poor but deserving students to quality tertiary education increased	4,326	4,326
3101000000000000	HIGHER EDUCATION PROGRAM	4,326	4,326
310100100001000	Provision of Higher Education Services	4,326	4,326
Grand Total		5,266	5,266

<p>PREPARED BY:</p> <p style="text-align: center;"> NIKKI ROSE C. VERGARA <hr/> Budget Officer III</p>	<p>CERTIFIED CORRECT:</p> <p style="text-align: center;"> ATTY. DANILO M. ABAYON <hr/> Asst. Director for Admin and Finance</p>	<p>APPROVED:</p> <p style="text-align: center;"> ENGR. ALEXANDER E. MAG-ISA, PhD.,PME <hr/> Campus Director</p>	<p>DATE:</p> <hr/> <p>DAY/MO/YEAR</p>
--	---	---	---------------------------------------

30000000000000	Operations	10,000	107,500	75,000	15,000	3,500	211,000
31000000000000	OO : Relevant and quality tertiary education ensured to achieve inclusive growth and access of poor but deserving students to quality tertiary education increased	10,000	107,500	75,000	15,000	3,500	211,000
31010000000000	HIGHER EDUCATION PROGRAM	10,000	107,500	75,000	15,000	3,500	211,000
31010020000000	Locally-Funded Project(s)	10,000	107,500	75,000	15,000	3,500	211,000
310100200027000	Construction of Campus Dormitory at TUP Cavite (Phase II)	0	0	75,000	0	0	75,000
310100200030000	Construction of Architecture and Engineering Building at TUP Cavite Campus (Phase I)	0	77,500	0	0	0	77,500
310100200031000	Renovation of Gymnasium at TUP Cavite Campus	0	30,000	0	0	0	30,000
310100200032000	Acquisition of One (1) Unit Electric PUV under Green Public Procurement for Sustainable and Equitable Campus Mobility	0	0	0	0	3,500	3,500
310100200033000	Acquisition of Mini Steam Power Plant/Boiler for BSME Program and Construction of Boiler Room at TUP Cavite Campus	10,000	0	0	15,000	0	25,000
310100_00000000	Project(s)	10,000	107,500	75,000	15,000	3,500	211,000
Grand Total		10,000	107,500	75,000	15,000	3,500	211,000

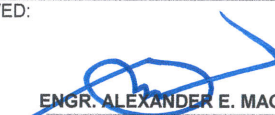
PREPARED BY:  NIKKI ROSE C. VERGARA Budget Officer III	CERTIFIED CORRECT:  ATTY. DANILO M. ABAYON Asst. Director for Admin and Finance	APPROVED:  ENGR. ALEXANDER E. MAG-ISA, PhD., PME Campus Director	DATE: DAY/MO/YEAR
---	--	---	--------------------------

STAFFING SUMMARY OF NON-PERMANENT POSITIONS

DEPARTMENT : State Universities and Colleges (SUCs)
 AGENCY : Technological University of the Philippines
 OPERATING UNIT : Technological University of the Philippines - Cavite
 YEAR : 2027

PAP Attribution	Organizational Unit	Position Title	Salary Grade	No. of Positions	No. of Months Employed Per Position	Total No. of Months Employed	Total Salary Based on Months Employed	Other Compensation													Total Compensation	
								PERA	RATA	Clothing/Uniform Allowance	Mid-Year Bonus	Year-End Bonus	Cash Gift	PEI	RLIP	Pag-IBIG	ECIP	PHIC	Medical Allowance	Compensation-Related Magna Carta Benefits		Total Other Compensation (Total of Columns 8-18)
(1)	(2)	(3)	(4)	(5)	(6)	(7)	(8)	(9)	(10)	(11)	(12)	(13)	(14)	(15)	(16)	(17)	(18)	(19)	(20)	(21)	(22)	(23)
TIER 1:																						
A. Casual																						
General Management and Supervision	General Administration and Support Services - TUP Cavite	Clerk I	03	6	12	72	1,232,640	144,000	0	42,000	102,720	102,720	30,000	30,000	147,917	14,400	7,200	30,403	42,000	0	693,360	1,926,000
Sub-Total, Casual				6	12	72	1,232,640	144,000	0	42,000	102,720	102,720	30,000	30,000	147,917	14,400	7,200	30,403	42,000	0	693,360	1,926,000
GRAND TOTAL, TIER 1				6	12	72	1,232,640	144,000	0	42,000	102,720	102,720	30,000	30,000	147,917	14,400	7,200	30,403	42,000	0	693,360	1,926,000
GRAND TOTAL				6	12	72	1,232,640	144,000	0	42,000	102,720	102,720	30,000	30,000	147,917	14,400	7,200	30,403	42,000	0	693,360	1,926,000

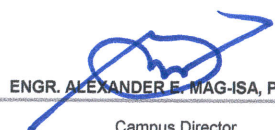
PREPARED BY :  LOVELY JOY V. AMAGO Administrative Officer IV (HRMO)	APPROVED BY :  ENGR. ALEXANDER E. MAG-ISA, PhD.,PME Campus Director	DATE : _____ DAY/MO/YEAR
---	--	--------------------------------

**LIST OF RETIREES
FOR PAYMENT OF TERMINAL LEAVE AND RETIREMENT GRATUITY BENEFITS
FY 2027**

DEPARTMENT : State Universities and Colleges (SUCs)
 AGENCY : Technological University of the Philippines
 OPERATING UNIT : Technological University of the Philippines - Cavite

NAMES OF RETIREES AND RETIREMENT LAW	Position at Ret. Date	Date (Mo/Day/Year)			Highest Monthly Salary (Per NOSA)	TERMINAL LEAVE			RETIREMENT GRATUITY		
		Birth	Orig. Appt.	Ret.		No. of Leave Credits Earned		Amount	Total Creditable Service	No. of Gratuity Months	Amount
						VL	SL				
(1)	(2)	(3)	(4)	(5)	(6)	(7)	(8)	(9)	(10)	(11)	(12)
For GSIS Members					60,356	110.07	160.77	787,797.35	0.00	0.00	0.00
Mandatory					60,356	110.07	160.77	787,797.35	0.00	0.00	0.00
RA8291					60,356	110.07	160.77	787,797.35	0.00	0.00	0.00
	Administrative Officer V	11-18-1962	11-16-1983	11-18-2027	60,356	110.07	160.77	787,797.35	0.00	0.00	0.00
Sub-Total - For GSIS Members					60,356	110.07	160.77	787,797.35	0.00	0.00	0.00
TOTAL					60,356	110.07	160.77	787,797.35	0.00	0.00	0.00

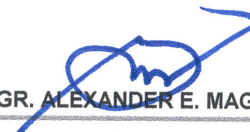
PREPARED BY:  LOVELY JOY V. AMAGO Administrative Officer IV (HRMO)	APPROVED BY:  ENGR. ALEXANDER E. MAG-ISA, PhD.,PME Campus Director	DATE: _____ DAY/MO/YEAR
--	--	-----------------------------------

COMPARISON OF APPROPRIATIONS AND OBLIGATIONS

FY 2025-2027

Department : State Universities and Colleges (SUCs)
 Agency : Technological University of the Philippines
 Operating Unit : Technological University of the Philippines - Cavite

PARTICULARS	AMOUNT IN P'000		
	2025 ACTUAL	2026 CURRENT	2027 PROPOSED
(1)	(2)	(3)	(4)
New General Appropriations	77,660	103,051	339,424
Specific Budgets of National Government Agencies	70,940	103,051	339,424
Miscellaneous Personnel Benefits Fund	4,549	0	0
Pension and Gratuity Fund	2,171	0	0
Continuing Appropriations	925	0	0
Specific Budgets of National Government Agencies	925	0	0
Automatic Appropriations	4,985	5,245	5,266
Retirement and Life Insurance Premiums	4,985	5,245	5,266
TOTAL OBLIGATION	83,570	108,296	344,690

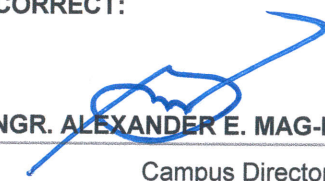
PREPARED BY:	CERTIFIED CORRECT:	DATE:
 NIKKI ROSE C. VERGARA Budget Officer III	 ENGR. ALEXANDER E. MAG-ISA, PHD.,PME Campus Director	15/04/2026 DAY/MO/YEAR

Department: State Universities and Colleges
 Agency: Technological University of the Philippines - Cavite Campus

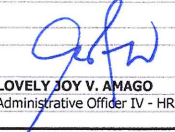

LOYALTY AWARDEES FOR FY 2027

NO.	NAME OF QUALIFIED EMPLOYEE	POSITION	DATE OF APPOINTMENT	EQUAL TO AGENCY SUBMISSION?	YEARS IN SERVICE (IN 2027)	AMOUNT	SCHEDULE OF PAY-OUT IN 2027												TOTAL
							JAN	FEB	MAR	APR	MAY	JUN	JUL	AUG	SEPT	OCT	NOV	DEC	
NON-TEACHING PERSONNEL																			
1	GASCON, Benedict F.	Administrative Officer V	16/10/1982		45	5,000.00										5,000.00		5,000.00	
2	VELOS, Sarah Jane D.	Registrar III	16/03/2007		20	5,000.00			5,000.00									5,000.00	
Sub-total						10,000.00	-	-	5,000.00	-	-	-	-	-	-	5,000.00	-	-	10,000.00
TEACHING PERSONNEL																			
1	BELTRAN, Emily L.	Professor VI	15/06/1992		35	5,000.00						5,000.00						5,000.00	
2	BELTRAN, Gil S.	Associate Professor V	01/10/1997		30	5,000.00										5,000.00		5,000.00	
3	FRIAS, Edmundo G.	Associate Professor V	01/07/1987		40	5,000.00						5,000.00						5,000.00	
4	REYES, Benefrido D.	Associate Professor IV	03/11/1997		30	5,000.00											5,000.00	5,000.00	
5	REYES, Maria Cecilia N.	Associate Professor III	17/11/1997		30	5,000.00											5,000.00	5,000.00	
6	SAULOG, Jessie C.	Associate Professor IV	15/06/1992		35	5,000.00						5,000.00						5,000.00	
Sub-total						30,000.00	0.00	0.00	0.00	0.00	0.00	10,000.00	5,000.00	0.00	0.00	5,000.00	10,000.00	0.00	30,000.00
Grand TOTAL						40,000.00	0.00	0.00	5,000.00	0.00	0.00	10,000.00	5,000.00	0.00	0.00	10,000.00	10,000.00	0.00	40,000.00

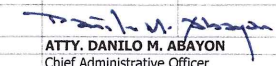
Prepared by:  Name: **LOVELY JOY V. AMAGO**
 Position: Administrative Officer IV - HRMO

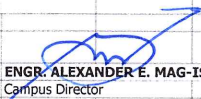
Reviewed by:  Name: **ATTY. DANILO M. ABAYON**
 Position: Chief Administrative Officer

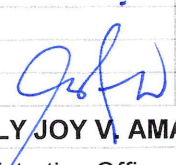
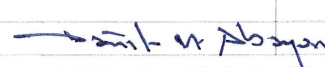
Approved by:  Name: **ENGR. ALEXANDER E. MAG-ISA, PhD., PME**
 Position: Campus Director

Department:	State Universities and Colleges			
Agency:	Technological University of the Philippines - Cavite Campus			
ANNIVERSARY BONUS (AB) FOR FY 2027				
FOUNDING YEAR*	NO. OF EMPLOYEES ENTITLED TO AB IN 2027	AMOUNT PER EMPLOYEE	TOTAL	MONTH OF PAYMENT IN 2027
1901			-	NONE
	N/A	N/A	N/A	
			-	
Total	0	-	-	
*Please upload legal basis of the founding year here:				
SIGNED SUBMISSIONS				
Prepared by:		Reviewed by:		Approved by:
				
Name: LOVELY JOY V. AMAGO	Name: ATTY. DANILO M. ABAYON	Name: ENGR. ALEXANDER E. MAG-ISA, PhD., PME		
Position: Administrative Officer IV - HRMO	Position: Chief Administrative Officer	Position: Campus Director		

Enrolment Data (Total for All Courses Offered) for Academic Years 2019-2020 to 2026-2027

State Universities and Colleges (SUCs)

SUC Name: **Technological University of the Philippines - Cavite**

Region: **National Capital Region (NCR)**

SUC Name: Technological University of the Philippines - Cavite	ENROLMENT															
	SY 2019-2020 (Actual)				SY 2020-2021 (Actual)				SY 2021-2022 (Actual)				SY 2022-2023 (Actual)			
	1st Semester	2nd Semester	Summer, if applicable	Total	1st Semester	2nd Semester	Summer, if applicable	Total	1st Semester	2nd Semester	Summer, if applicable	Total	1st Semester	2nd Semester	Summer, if applicable	Total
Total	2,028	1,855	1	3,884	2,149	1,997	244	4,390	2,613	2,485	309	5,407	2,485	2,399	229	5,113
TUP CAVITE	2,028	1,855	1	3,884	2,149	1,997	244	4,390	2,613	2,485	309	5,407	2,485	2,399	229	5,113

SUC Name: Technological University of the Philippines - Cavite	SY 2023-2024 (Actual)				SY 2024-2025 (Actual)				SY 2025-2026 (Actual)				SY 2026-2027 (Projected)			
	1st Semester	2nd Semester	Summer, if applicable	Total	1st Semester	2nd Semester	Summer, if applicable	Total	1st Semester	2nd Semester	Summer, if applicable	Total	1st Semester	2nd Semester	Summer, if applicable	Total
Total	2,234	2,014	202	4,450	2,230	2,132	181	4,543	2,111	2,039	0	4,150	2,214	2,175	221	4,610
TUP CAVITE	2,234	2,014	202	4,450	2,230	2,132	181	4,543	2,111	2,039	0	4,150	2,214	2,175	221	4,610

Prepared by:

SARAH JANE D. VELOS
Registrar III

Recommended by:

MARIA CECILIA N. REYES
Asst. Director for Academic Affairs

Approved by:

ENGR. ALEXANDER E. MAG-ISA, PhD.,PME
Campus Director

ADDITIONAL MOOE REQUIREMENTS FOR 2027 (COST TO OPERATE NEWLY-COMPLETED FACILITIES FUNDED UNDER THE GAA AS OF DECEMBER 31, 2025)

SUC: Technological University of the Philippines - Cavite Campus

(in thousand pesos)

A. Buildings and Other Structures				Additional Requirements																		
P/A/Ps	Projects Completed in 2025			Electricity			Water			Insurance Expenses			Janitorial Services Requirement			Social Services Requirement			Office Supplies	Total Cost to Operate		
	Name of Building / Structure	Date of Completion	Source of funds for construction	Estimated additional KWH	Rate per KWH	Total, Electricity	Estimated additional cu.m	Rate per cu.m	Total, Water Expenses	Insurance for Newly Completed Buildings based on GSIS standard rates	Estimated Number of Additional Personnel	Rate per Existing Contract/N WPC Regional Rate	Total JS Requirement	Estimated Number of Additional Personnel	Rate per Existing Contract/N WPC Regional Rate	Total SS Requirement						
General Administration and Support						-			-			-				-			-		-	-
	none					-			-			-				-			-		-	-
Support to Operations						-			-			-				-			-		-	-
	none					-			-			-				-			-		-	-
Higher Education Program						-			-			-				-			-		-	-
	none					-			-			-				-			-		-	-
Advanced Education Program						-			-			-				-			-		-	-
	none					-			-			-				-			-		-	-
Research Program						-			-			-				-			-		-	-
	none					-			-			-				-			-		-	-
Technical Advisory Extension Program						-			-			-				-			-		-	-
	none					-			-			-				-			-		-	-
Custodial Services Program						-			-			-				-			-		-	-
	none					-			-			-				-			-		-	-
Hospital Services Program						-			-			-				-			-		-	-
	none					-			-			-				-			-		-	-
Total						-			-			-				-			-		-	-

B. Machineries and Equipment				Additional Requirements																		
P/A/Ps	Machineries and Equipment in 2025			Electricity			Water			Insurance Expenses			Janitorial Services Requirement			Social Services Requirement			Office Supplies	Total Cost to Operate		
	Type of Machinery	No. of Units	Source of funds for acquisition	Estimated additional KWH	Rate per KWH	Total, Electricity	Estimated additional cu.m	Rate per cu.m	Total, Water Expenses	Insurance for Newly Completed Buildings based on GSIS standard rates	Estimated Number of Additional Personnel	Rate per Existing Contract/N WPC Regional Rate	Total JS Requirement	Estimated Number of Additional Personnel	Rate per Existing Contract/N WPC Regional Rate	Total SS Requirement						
General Administration and Support						-			-			-				-			-		-	-
	none					-			-			-				-			-		-	-
Support to Operations						-			-			-				-			-		-	-
	none					-			-			-				-			-		-	-
Higher Education Program						364,203.00			-			-				-			-		-	364,203.00
	SMART TV 55"	25	GAA	4,500	13.5	60,750.00			-			-				-			-		60,750.00	
	Window type inverter aircon 2HP	2	GAA	8,322	13.5	112,347.00			-			-				-			-		112,347.00	
	Split-type aircon 2HP	2	GAA	5,256	13.5	70,956.00			-			-				-			-		70,956.00	
	Floor Mounted aircon (5TR)	1	GAA	8,900	13.5	120,150.00			-			-				-			-		120,150.00	
						-			-			-				-			-		-	-
Advanced Education Program						-			-			-				-			-		-	-
	none					-			-			-				-			-		-	-
Research Program						-			-			-				-			-		-	-

	none					-			-				-			-			-
Technical Advisory Extension Program						-			-				-			-			-
	none					-			-				-			-			-
Custodial Services Program						-			-				-			-			-
	none					-			-				-			-			-
Hospital Services Program						-			-				-			-			-
	none					-			-				-			-			-
Total						364,203.00			-				-			-			-

Grand Total						364,203.00			-				-			-			-
--------------------	--	--	--	--	--	-------------------	--	--	---	--	--	--	---	--	--	---	--	--	---

Prepared by:

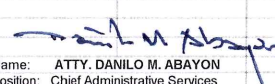
 Name: NIKKI ROSE C. VERGARA
 Position: Budget Officer III

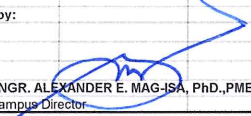
Reviewed by:

 Name: ATTY. DANILO M. ABAYON
 Position: Chief Administrative Services

Approved by:

 Name: ENGR. ALEXANDER E. MAG-JSA, PhD, PME
 Position: Campus Director

ESTIMATED OVERTIME SERVICES OF ADMINISTRATIVE EMPLOYEES FOR FY 2027

No.	NAME	POSITION TITLE	SG-STEP	MONTHLY BASIC SALARY	HOURLY RATE	RATE PER SEMESTER (1ST) (3 Hrs*5 Days*18 Weeks)	RATE PER SEMESTER (2ND) (3 Hrs*5 Days*18 Weeks)	ESTIMATED ANNUAL OVERTIME PAY
1		CHIEF ADMINISTRATIVE OFFICER	24-2	108,627.00	771.50	208,304.62	208,304.62	416,609.23
2		ACCOUNTANT III	19-1	61,916.00	439.74	118,730.97	118,730.97	237,461.93
3		ADMINISTRATIVE OFFICER V	18-8	60,356.00	428.66	115,739.49	115,739.49	231,478.98
4		REGISTRAR III	18-2	56,885.00	404.01	109,083.45	109,083.45	218,166.90
5		ADMINISTRATIVE OFFICER V	18-1	56,332.00	400.09	108,023.01	108,023.01	216,046.02
6		ADMINISTRATIVE OFFICER V	18-1	56,332.00	400.09	108,023.01	108,023.01	216,046.02
7		ADMINISTRATIVE OFFICER IV	15-1	44,148.00	313.55	84,658.81	84,658.81	169,317.61
8		ADMINISTRATIVE OFFICER IV	15-1	44,148.00	313.55	84,658.81	84,658.81	169,317.61
9		ADMINISTRATIVE ASSISTANT III	9-1	25,433.00	180.63	48,770.67	48,770.67	97,541.34
10		ADMINISTRATIVE ASSISTANT II	8-1	23,399.00	166.19	44,870.24	44,870.24	89,740.48
11		ADMINISTRATIVE AIDE VI	6-2	20,620.00	146.45	39,541.19	39,541.19	79,082.39
12		ADMINISTRATIVE AIDE VI	6-2	20,620.00	146.45	39,541.19	39,541.19	79,082.39
13		ADMINISTRATIVE AIDE VI	6-1	20,474.00	145.41	39,261.22	39,261.22	78,522.44
14		ADMINISTRATIVE AIDE IV	4-1	18,180.00	129.12	34,862.22	34,862.22	69,724.43
15		ADMINISTRATIVE AIDE IV	4-2	18,309.00	130.04	35,109.59	35,109.59	70,219.18
16		ADMINISTRATIVE AIDE III	3-1	17,120.00	121.59	32,829.55	32,829.55	65,659.09
17		ADMINISTRATIVE AIDE III	3-1	17,120.00	121.59	32,829.55	32,829.55	65,659.09
18		ADMINISTRATIVE AIDE III	3-1	17,120.00	121.59	32,829.55	32,829.55	65,659.09
19		ADMINISTRATIVE AIDE III	3-1	17,120.00	121.59	32,829.55	32,829.55	65,659.09
20		ADMINISTRATIVE AIDE III	3-1	17,120.00	121.59	32,829.55	32,829.55	65,659.09
21		ADMINISTRATIVE AIDE III	3-1	17,120.00	121.59	32,829.55	32,829.55	65,659.09
22		ADMINISTRATIVE AIDE III	3-1	17,120.00	121.59	32,829.55	32,829.55	65,659.09
						1,448,985.30	1,448,985.30	2,897,970.60

Estimated Annual Overtime 2,897,970.60

TIER 1 Appropriation -

TIER 2 Proposal 2,897,970.60

GAP from TIER 1 appropriation

Prepared By:

NIKKI ROSE C. VERGARA
 Administrative Officer V - Budget

Noted by:

ATTY. DANILO M. ABAYON
 Asst. Director for Admin and Finance

Approved by:

ENGR. ALEXANDER E. MAG-ISA, PhD.,PME
 Campus Director

ESTIMATED OVERLOAD HONORARIUM OF FACULTY FOR FY 2027

No.	NAME	POSITION TITLE	SG-STEP	MONTHLY BASIC SALARY	HOURLY RATE	HOURS PER WEEK	NO. OF WEEKS	SY 2026-2027 2nd SEM	SY 2027-2028 1st SEM	ESTIMATED ANNUAL OVERLOAD
1		PROFESSOR VI	29-3	200,519.00	1,879.26	3	18	101,480.26	101,480.26	202,960.52
2		PROFESSOR V	28-1	173,788.00	1,628.74	3	18	87,952.02	87,952.02	175,904.04
3		ASSOCIATE PROFESSOR V	23-4	99,320.00	930.83	3	18	50,264.66	50,264.66	100,529.32
4		ASSOCIATE PROFESSOR V	23-2	96,612.00	905.45	6	18	97,788.35	97,788.35	195,576.70
5		ASSOCIATE PROFESSOR V	23-2	96,612.00	905.45	6	18	97,788.35	97,788.35	195,576.70
6		ASSOCIATE PROFESSOR IV	22-2	86,598.00	811.60	6	18	87,652.42	87,652.42	175,304.83
7		ASSOCIATE PROFESSOR IV	22-3	87,785.00	822.72	6	18	88,853.87	88,853.87	177,707.74
8		ASSOCIATE PROFESSOR III	21-2	77,628.00	727.53	6	18	78,573.20	78,573.20	157,146.40
9		ASSOCIATE PROFESSOR III	21-2	77,628.00	727.53	6	18	78,573.20	78,573.20	157,146.40
10		ASSOCIATE PROFESSOR I	19-2	62,729.00	587.90	6	18	63,492.79	63,492.79	126,985.58
11		ASSOCIATE PROFESSOR I	19-2	62,729.00	587.90	9	18	95,239.18	95,239.18	190,478.36
12		ASSISTANT PROFESSOR IV	18-2	56,885.00	533.13	9	18	86,366.45	86,366.45	172,732.90
13		ASSISTANT PROFESSOR IV	18-2	56,885.00	533.13	9	18	86,366.45	86,366.45	172,732.90
14		ASSISTANT PROFESSOR IV	18-2	56,885.00	533.13	9	18	86,366.45	86,366.45	172,732.90
15		ASSISTANT PROFESSOR IV	18-1	56,332.00	527.94	9	18	85,526.85	85,526.85	171,053.70
16		ASSISTANT PROFESSOR IV	18-8	60,356.00	565.66	9	18	91,636.34	91,636.34	183,272.68
17		ASSISTANT PROFESSOR III	17-2	52,381.00	490.91	9	18	79,528.19	79,528.19	159,056.37
18		ASSISTANT PROFESSOR II	16-2	48,286.00	452.54	9	18	73,310.90	73,310.90	146,621.79
19		ASSISTANT PROFESSOR II	16-2	48,286.00	452.54	12	18	97,747.86	97,747.86	195,495.72
20		ASSISTANT PROFESSOR I	15-2	44,564.00	417.65	12	18	90,213.22	90,213.22	180,426.45
21		COLLEGE LIBRARIAN II	15-8	47,172.00	442.10	12	18	95,492.73	95,492.73	190,985.47
22		INSTRUCTOR III	14-1	40,505.00	379.61	12	18	81,996.38	81,996.38	163,992.76
23		INSTRUCTOR III	14-1	40,505.00	379.61	12	18	81,996.38	81,996.38	163,992.76
24		INSTRUCTOR II	13-5	38,948.00	365.02	12	18	78,844.46	78,844.46	157,688.92
25		INSTRUCTOR I	12-1	35,650.00	334.11	12	18	72,168.15	72,168.15	144,336.30
26		INSTRUCTOR I	12-1	35,650.00	334.11	12	18	72,168.15	72,168.15	144,336.30
27		INSTRUCTOR I	12-1	35,650.00	334.11	12	18	72,168.15	72,168.15	144,336.30
28		INSTRUCTOR I	12-1	35,650.00	334.11	12	18	72,168.15	72,168.15	144,336.30
29		INSTRUCTOR I	12-1	35,650.00	334.11	12	18	72,168.15	72,168.15	144,336.30
30		INSTRUCTOR I	12-1	35,650.00	334.11	12	18	72,168.15	72,168.15	144,336.30

ESTIMATED OVERLOAD HONORARIUM OF FACULTY FOR FY 2027

No.	NAME	POSITION TITLE	SG-STEP	MONTHLY BASIC SALARY	HOURLY RATE	HOURS PER WEEK	NO. OF WEEKS	SY 2026-2027 2nd SEM	SY 2027-2028 1st SEM	ESTIMATED ANNUAL OVERLOAD
31		INSTRUCTOR I	12-1	35,650.00	334.11	12	18	72,168.15	72,168.15	144,336.30
32		INSTRUCTOR I	12-1	35,650.00	334.11	12	18	72,168.15	72,168.15	144,336.30
33		INSTRUCTOR I	12-1	35,650.00	334.11	12	18	72,168.15	72,168.15	144,336.30
34		INSTRUCTOR I	12-1	35,650.00	334.11	12	18	72,168.15	72,168.15	144,336.30
35		INSTRUCTOR I	12-1	35,650.00	334.11	12	18	72,168.15	72,168.15	144,336.30
36		INSTRUCTOR I	12-1	35,650.00	334.11	12	18	72,168.15	72,168.15	144,336.30
37		INSTRUCTOR I	12-1	35,650.00	334.11	12	18	72,168.15	72,168.15	144,336.30
38		INSTRUCTOR I	12-1	35,650.00	334.11	12	18	72,168.15	72,168.15	144,336.30
39		INSTRUCTOR I	12-1	35,650.00	334.11	12	18	72,168.15	72,168.15	144,336.30
40		INSTRUCTOR I	12-1	35,650.00	334.11	12	18	72,168.15	72,168.15	144,336.30
41		INSTRUCTOR I	12-1	35,650.00	334.11	12	18	72,168.15	72,168.15	144,336.30
42		INSTRUCTOR I	12-1	35,650.00	334.11	12	18	72,168.15	72,168.15	144,336.30
43		INSTRUCTOR I	12-1	35,650.00	334.11	12	18	72,168.15	72,168.15	144,336.30
44		INSTRUCTOR I	12-1	35,650.00	334.11	12	18	72,168.15	72,168.15	144,336.30
45		INSTRUCTOR I	12-2	35,771.00	335.25	12	18	72,413.10	72,413.10	144,826.19
46		INSTRUCTOR I	12-1	35,650.00	334.11	12	18	72,168.15	72,168.15	144,336.30
47		INSTRUCTOR I	12-1	35,650.00	334.11	12	18	72,168.15	72,168.15	144,336.30
48		INSTRUCTOR I	12-1	35,650.00	334.11	12	18	72,168.15	72,168.15	144,336.30
49		INSTRUCTOR I	12-1	35,650.00	334.11	12	18	72,168.15	72,168.15	144,336.30
50		INSTRUCTOR I	12-1	35,650.00	334.11	12	18	72,168.15	72,168.15	144,336.30
51		INSTRUCTOR I	12-1	35,650.00	334.11	12	18	72,168.15	72,168.15	144,336.30
52		INSTRUCTOR I	12-1	35,650.00	334.11	12	18	72,168.15	72,168.15	144,336.30
53		INSTRUCTOR I	12-8	37,552.00	351.94	12	18	76,018.47	76,018.47	152,036.93
54		INSTRUCTOR I	12-1	35,650.00	334.11	12	18	72,168.15	72,168.15	144,336.30
55		INSTRUCTOR I	12-1	35,650.00	334.11	12	18	72,168.15	72,168.15	144,336.30
56		INSTRUCTOR I	12-8	37,552.00	351.94	12	18	76,018.47	76,018.47	152,036.93
57		INSTRUCTOR I	12-1	35,650.00	334.11	12	18	72,168.15	72,168.15	144,336.30
58		INSTRUCTOR I	12-1	35,650.00	334.11	12	18	72,168.15	72,168.15	144,336.30
GRAND TOTAL								4,577,527.50	4,577,527.50	9,155,054.99

ESTIMATED OVERLOAD HONORARIUM OF FACULTY FOR FY 2027

No.	NAME	POSITION TITLE	SG-STEP	MONTHLY BASIC SALARY	HOURLY RATE	HOURS PER WEEK	NO. OF WEEKS	SY 2026-2027 2nd SEM	SY 2027-2028 1st SEM	ESTIMATED ANNUAL OVERLOAD
-----	------	----------------	---------	----------------------	-------------	----------------	--------------	-------------------------	-------------------------	---------------------------

Estimated Annual Overload	9,155,054.99
TIER 1 Appropriation	2,076,000.00
TIER 2 Proposal	7,079,054.99 GAP from TIER 1 appropriation

Prepared By:



NIKKI ROSE C. VERGARA
 Administrative Officer V - Budget

Noted by:

ATTY. DANILO M. ABAYON
 Asst. Director for Admin and Finance

Approved by:

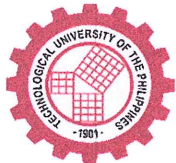
ENGR. ALEXANDER E. MAG-ISA, PhD.,PME
 Campus Director



Technological University of the Philippines

Cavite Campus

Carlos Q. Trinidad Avenue, Salawag, Dasmarinas City, Cavite

PRICE SCHEDULE FORM FOR SECURITY SERVICES

FY 2027

PARTICULARS	DAY SHIFT	NIGHT SHIFT
	7 Days 12 hrs work/day 8 Security Guard	7 Days 12 hrs work/day 6 Security Guard
Basic Rate (Daily Wage)	₱ 600.00	₱ 600.00
No. of Days per Year	395	395
Amount Directly to Guard		
Ave. Pay per Month (DW x no of days per year/12)	19,750.00	19,750.00
Night Differential Pay (Ave. Pay per Month x 10%)	-	1,975.00
13th Month Pay (DW x 365/12/12)	1,520.83	1,520.83
5 Days Incentive Pay (DW x 5/12)	250.00	250.00
Uniform Allowance (R.A. 5487)	100.00	100.00
Overtime Pay	₱12,453.25	₱12,453.25
<i>Total Amount Directly to Guard</i>	34,074.08	36,049.08
Amount to Government in Favor of Guard		
Retirement Pay (DW x 22.5/12)	1,125.00	1,125.00
SSS Premium	2,000.00	2,000.00
SSS Mandatory Provident Fund (MPF)	1,400.00	1,500.00
PhilHealth Contribution	493.75	493.75
EC Insurance Premiums	30.00	30.00
PAG-IBIG Fund	200.00	200.00
<i>Total Amount to Government in Favor of Guard</i>	5,248.75	5,348.75
A. Total Amount to Guard and Government	39,322.83	41,397.83
B. Administrative Overhead	5,898.43	6,209.68
C. Value Added Tax (12%)	707.81	745.16
D. Monthly Rate per Security Personnel (A + B + C)	45,929.07	48,352.67
E. Total Monthly Contract Rate (Total of D x No. of Guards)	367,432.55	290,116.02
F. Total Annual Rate (Total of E x 12 months)	4,409,190.66	3,481,392.19
TOTAL CONTRACT RATE		7,890,582.85



Technological University of the Philippines
Cavite Campus

Carlos Q. Trinidad Avenue, Salawag, Dasmariñas City, Cavite

PRICE SCHEDULE FORM FOR JANITORIAL SERVICES
FY 2027

Item No.	PARTICULARS	Eighteen (18) Janitors 6 days/week 8 hours/day
	Basic Rate (Daily Wage)	₱ 600.00
	No. of Days per Year	313
	Amount Directly Paid for Janitorial Personnel	
	Ave. Pay per Month (DW x no. of days per year/12)	15,650.00
	13th Month Pay (Ave. pay per month / 12 months)	1,304.17
	5 Days Incentive Pay (DW x 5/12)	250.00
A.	Total Amount Directly to Janitorial Personnel	17,204.17
	Amount to be Paid to Government for Janitorial Personnel	
	SSS Premium	1,550.00
	PhilHealth Contribution	391.25
	EC Insurance Premiums	30.00
	PAG-IBIG Fund	200.00
B.	Total Amount to Government in Favor of Janitorial Personnel	2,171.25
C.	Total Amount to Janitorial Personnel and Government (A + B)	19,375.42
D.	Administrative Overhead / Agency Fee	1,937.54
E.	Cost of Supplies and Materials	1,937.54
F.	Value Added Tax (C + D + E x 12%)	2,790.06
G.	Total Contract Rate for Eight (8) Hours (C + D + E + F)	26,040.56
H.	Total Contract Rate for Twenty (18) Janitors per Month	468,730.08
I.	Total Contract Rate for One (1) Year	5,624,760.96



JUSTIFICATION FOR THE FY 2027 TIER II BUDGET PROPOSAL

PERSONNEL SERVICES

Honoraria	<p>Budget: Php 7,079,055.00</p> <p>Currently, the Campus has an average of 2,100 enrolled students. The further subjects to be offered that come with the influx of enrollees shall be charged to the overload of faculty members. Existing faculty plantilla positions remain insufficient to fully cover the required teaching loads due to retirements and resignations. Also, the implementation of revised curricula, accreditation standards, and CHED requirements necessitates the offering of specialized and major subjects that can only be handled by faculty with appropriate expertise. It is also noted that from previous years, trends for the salary rate of Faculty Members are increasing due to Salary Standardization Law, and JC 3, thus a need for additional allotment to cover their increasing overload payment. An estimated overload computation is included in this proposal.</p>
Overtime Pay	<p>Budget: Php 2,897,971.00</p> <p>Because of staffing shortages in each office, increased workload, and time-bound government requirements, TUP Cavite plans to compensate administrative employees for overtime beyond their regular work hours. The growing volume of transactions in budgeting, accounting, procurement, payroll, records management, and mandatory reporting to oversight agencies such as DBM, COA, and CHED necessitates the extension of working hours, particularly during peak periods. Existing staffing levels are insufficient to fully address operational demands, thereby requiring authorized overtime work to ensure uninterrupted delivery of services and compliance with statutory deadlines. Approval of this request will sustain operational efficiency, accountability, and timely public service delivery. An estimated overtime pay computation is included in this proposal.</p>

MAINTENANCE AND OTHER OPERATING EXPENSES

Telephone Expense - Mobile	<p>Budget: Php 17,000.00</p> <p>TUP Cavite respectfully request this Tier 2 proposal to fund the additional mobile allowance increase for eligible personnel, in accordance with DBM Budget Circular No. 2024-2 dated August 2, 2024, which provides updated guidelines on the payment and reimbursement of communication expenses, including mobile/telephone costs, for government officials and employees in the performance of official duties. Approval of this request will ensure compliance with the latest DBM policy while supporting operational communication needs essential to timely coordination and service delivery.</p>
-----------------------------------	---



<p>Janitorial Services</p>	<p>Budget: Php 2,550,709.00</p> <p>This proposal is requested to augment funding for janitorial services to ensure the continuous maintenance of cleanliness, sanitation, and orderliness on campus. With the expansion of facilities, projected increase in student population, and full resumption of face-to-face classes and institutional activities, the demand for custodial services has significantly increased. Adequate janitorial services are essential to maintain a safe, healthy, and conducive learning and working environment in compliance with government health and safety standards. Approval of this request will sustain operational efficiency and uphold institutional responsibility for providing a clean and sanitary campus environment.</p>
<p>Security Services</p>	<p>Budget: Php 3,402,956.00</p> <p>This proposal is requested to augment funding for security services to ensure the safety and protection of students, personnel, facilities, and institutional assets. With the expansion of campus facilities, a projected increase in student population, and the conduct of regular academic and public activities, the demand for adequate security coverage has significantly increased. Continuous security presence is essential to maintain peace and order, regulate campus access, and prevent potential risks or incidents. Approval of this request will enable the University to sustain a secure and orderly environment conducive to learning and public service delivery.</p>
<p>Insurance Expense</p>	<p>Budget: Php 1,000,000</p> <p>Currently, the budget allocated from the Income Fund to cover the Insurance Expense for TUPC Properties and Facilities is insufficient to insure all properties, resulting in an AOM from COA. To address the gap in the Income Fund, an additional one (1) million from Regular Fund 01 is included in this proposal.</p>

CAPITAL OUTLAY

<p>Construction of Campus Dormitory at TUP Cavite (Phase II)</p>	<p>Budget: 75,000,000.00</p> <p>The construction of Campus Dormitory at TUP Cavite (Phase I) is ongoing and is expected to be completed in the 2nd quarter of 2026. This project is a justified and crucial initiative aimed at addressing the residential needs of students and enhancing their overall campus experience. Recognizing the importance of providing students with a supportive environment for learning and personal development, especially for those from distant locations, the dormitory project offers well-designed living quarters and common areas.</p> <p>The proposed dormitory is made up of individual rooms, communal rooms where students live, and common areas and amenities to foster social interaction and community building. The common space contains the lobby, waiting area, stairs, elevator, laundry room,</p>
---	---



	<p>kitchen, and restrooms. Each room in the boys' and girls' areas can include three double decks, three study desks, two lavatories, and one shower area. It also offers an entertainment space, a conference room, and a lobby area if needed for additional student support.</p> <p>The project is a continuation of the approved Phase 1 works and is necessary to complete the planned facility design and achieve its intended capacity and functionality. Delays in funding may result in project cost escalation. Approval of this request will ensure project continuity and strengthen the Campus's physical infrastructure in support of its expanding academic operations.</p>
<p>Acquisition of Mini Steam Power Plant/Boiler for BSME Program and Construction of Boiler Room at TUP Cavite Campus</p>	<p>Budget: Php 25,000,000.00</p> <p>This is a specialized technical facility project comprising two main components: the acquisition of a Mini Steam Power Plant/Boiler, and the construction of a dedicated, safe Boiler Room to house this equipment. The definite purpose is to provide students in the BS Mechanical Engineering (BSME) program with high-fidelity, industrial-scale, hands-on training experience in energy generation, thermodynamics, and steam power operation. This facility will serve as a specialized laboratory for advanced practical instruction and technology utilization.</p> <p>This project addresses the critical gap between theoretical mechanical engineering instruction and the practical demands of industrial power generation, crucial for key sectors like Energy and Manufacturing. The acquisition of the Mini Steam Power Plant provides essential, industry-standard equipment necessary for scaling up technology adoption and hands-on utilization among future engineers. This investment ensures that graduates possess the immediate job-ready technical competencies and applied knowledge required to transform production sectors through modern industrial practices.</p> <p>The Mini Steam Power Plant/Boiler consists of a boiler unit, fuel source, steam generator, and a comprehensive system of control, instrumentation, and safety devices. The project also encompasses the construction of a dedicated Boiler Room, ensuring a safe and purpose-built space to house the mini-steam power plant ideally situated in proximity to the academic facilities of the BSME program.</p>
<p>Construction of Architecture and Engineering Building at TUP Cavite Campus (Phase I)</p>	<p>Budget: Php 77,500,000.00</p> <p>This project is a vital undertaking aimed at creating a purpose-built facility tailored to the specific needs of architecture and engineering programs. Envisioned as a hub for academic excellence and innovation, the building's cutting-edge design incorporates specialized laboratories, CAD studios, and collaborative spaces to provide students and faculty with an environment conducive to theoretical learning, hands-on practical experience, and collaborative research.</p> <p>The building consists of various features such as lecture room, laboratory rooms to house lab equipment, CAD rooms, multi-purpose hall, offices, conference room, multi-media center, and E-library. These are in accordance with the instructional facilities stated in section 2.4 of CMO 86, series 2017. Once operationalized, this building will significantly contribute to the accommodation of the projected 13.7% increase in population of students for the next 10</p>



	<p>years especially when the complete engineering program has been implemented, and it will also support the plan to offer an architecture program.</p>
<p>Renovation of Gymnasium at TUP Cavite Campus</p>	<p>Budget: Php 30,000,000.00</p> <p>This is a project for the comprehensive renovation and upgrade of the existing campus gymnasium and related athletic/recreational facilities. The specific components include structural repairs, modernization of sporting equipment, improvement of safety features, and enhancement of ancillary facilities (e.g., locker rooms, seating areas) to meet modern standards. The facility's definite purpose is to provide a safe, functional, and enhanced venue for physical activity, health, and campus community engagement.</p> <p>The renovation addresses the critical development gap posed by the deterioration of recreational infrastructure, which limits the university's capacity to fully support the physical, mental, and social well-being of its population. An upgraded gymnasium revitalizes facilities essential for physical fitness and community engagement, serving as a vital component in improving the social determinants of student health. This project aligns with the PDP mandate to ensure that communities and schools support physical, mental, and social well-being for all, allowing Filipinos to enjoy longer and healthier lives and achieve fulfillment.</p> <p>The project includes the following components: firstly, the construction of one covered court designed to accommodate various sports such as basketball, volleyball, and badminton. This multipurpose court will serve as a dynamic space for students and the campus community to engage in a range of athletic activities. Additionally, the project features the establishment of one adjacent room specifically designated for table tennis, providing a dedicated space for this popular recreational sport.</p>
<p>Acquisition of Electric PUV under Green Public Procurement for Sustainable and Equitable Campus Mobility</p>	<p>Budget: Php 3,500,000.00</p> <p>This project focuses on the strategic Green Procurement of one (1) unit of the Electric PUV Class 2 Battery Electric Vehicle (BEV) to launch a pilot low-emission, high-capacity transport service. The procurement aligns with the PDP's strategy to strengthen green public procurement and increase the adoption of e-vehicles to reduce transport costs and GHG emissions. The components include the BEV unit (featuring specialized energy-efficient air conditioning and a regenerative braking system) and the necessary charging infrastructure. The definite purpose is to transition the campus fleet towards low-carbon technology and establish an affordable, reliable, and inclusive transport service for students and employees for official business.</p> <p>This initiative addresses the dual development gap of significant transport-related greenhouse gas (GHG) emissions and the high financial burden of commuting, which contributes to student dropout rates. By acquiring this zero-emission Electric PUV through green procurement principles, the project enables the low carbon economy transition and advances climate action, aligning with the national commitment to green economic transformation. Concurrently, the service provides an affordable and inclusive mode of transport,</p>



thereby strengthening the protection of student capabilities and ensuring access to high-quality lifelong learning opportunities.

The core component is of one (1) high-capacity PUV Class 2 Battery Electric Vehicle (BEV), specifically chosen for its energy efficiency, low maintenance costs, and high passenger capacity (22+9). An essential accompanying component is the Installation of Required Charging Infrastructure to ensure the continuous and optimal operational viability of the single BEV unit, supported by its 70kWh battery and rapid charging capability. The project includes the Implementation of an Equitable Fare and Route Service Plan designed to reduce commuting costs for students and promote inclusive access across the campus community. Finally, Performance Monitoring and Reporting mechanisms will be established to track the reduction in transportation-related GHG emissions and assess the fleet's positive impact on student retention and institutional climate action compliance.

Prepared by:

NIKKI ROSE C. VERGARA
Budget Officer III

Certified by:

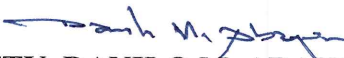
ATTY. DANILO M. ABAYON
Assistant Director for Admin and Finance

Approved by:

ENGR. ALEXANDER E. MAG-ISA, PhD., PME
Campus Director



INDICATIVE ANNUAL PROCUREMENT PLAN FY 2027

TECHNOLOGICAL UNIVERSITY OF THE PHILIPPINES - CAVITE

ANNUAL PROCUREMENT PLAN FOR FY 2027

INDICATIVE
 FINAL
 UPDATED [Version No. 1]

PROCUREMENT PROJECT DETAILS						PROJECTED TIMELINE (MM/YYYY)		FUNDING DETAILS		PROCUREMENT STRATEGY OR TOOLS	REMARKS (Other relevant descriptions of the procurement project, if applicable)
Project Title	End-User or Implementing Unit	General Description of the Project	Mode of Procurement	To be covered by an Early Procurement Activity? (Yes/No)	Criteria for Bid Evaluation (Including Sustainability and Domestic Preference)	Start of Procurement Activity	End of Procurement Activity	Source of Fund	Estimated Budget / Approved Budget for the Contract (PhP)		
Column 1	Column 2	Column 3	Column 4	Column 5	Column 6	Column 7	Column 8	Column 9	Column 10	Column 11	Column 12
General Requirements											
Procurement of Janitorial Services	GAS / HES	Procurement contract for janitorial services is essential for the maintaining cleanliness and managing of school properties and community within the Campus premises.	Public Bidding	Yes	LCRB	October 2026	December 2026	GOP	2,600,000.00		
Procurement of Security Services	GAS / HES	Procurement contract for security services is essential for the safety and security of school properties and community within the Campus premises.	Public Bidding	Yes	LCRB	October 2026	December 2026	GOP	3,800,000.00		
Provision for Supplies and Materials for Administrative Sector	GAS	Supply and delivery of supplies necessary for the daily operations of all administrative and finance offices to ensure the availability of essential materials needed for efficient and continuous delivery of administrative and financial services.	Small Value Procurement	No	N/A	January 2027	December 2027	GOP	883,000.00		
Provision for Supplies and Materials for Auxilliary Services	STO	Supply and delivery of supplies and materials necessary for the daily operations of auxilliary services	Small Value Procurement	No	N/A	January 2027	December 2027	GOP	222,000.00		
Provision for Supplies and Materials for Higher Education Services	HES	Supply and delivery of supplies necessary for the daily operations of academic sector to ensure the availability of essential materials needed for efficient and continuous delivery of services	Small Value Procurement	No	N/A	January 2027	December 2027	GOP	479,000.00		
Provision for Supplies and Materials for Research and Extension Sector	RESEARCH/ EXTENSION	Supply and delivery of supplies necessary for the daily operations of research services to ensure the availability of essential materials needed for efficient and continuous delivery of services.	Small Value Procurement	No	N/A	January 2027	December 2027	GOP	130,000.00		

TECHNOLOGICAL UNIVERSITY OF THE PHILIPPINES - CAVITE

ANNUAL PROCUREMENT PLAN FOR FY 2027

INDICATIVE
 FINAL
 UPDATED [Version No. 1]

PROCUREMENT PROJECT DETAILS						PROJECTED TIMELINE (MM/YYYY)		FUNDING DETAILS		PROCUREMENT STRATEGY OR TOOLS	REMARKS (Other relevant descriptions of the procurement project, if applicable)
Project Title	End-User or Implementing Unit	General Description of the Project	Mode of Procurement	To be covered by an Early Procurement Activity? (Yes/No)	Criteria for Bid Evaluation (Including Sustainability and Domestic Preference)	Start of Procurement Activity	End of Procurement Activity	Source of Fund	Estimated Budget / Approved Budget for the Contract (Php)		
Column 1	Column 2	Column 3	Column 4	Column 5	Column 6	Column 7	Column 8	Column 9	Column 10	Column 11	Column 12
General Requirements											
Provision for the purchase of Accountable Forms	GAS	This project covers the procurement of various accountable forms required for the efficient and compliant operations of the agency.	Small Value Procurement	No	N/A	January 2027	December 2027	GOP	27,000.00		
Provision for the procurement of Fuel/Oil/Lubricants	GAS	Procurement of fuel/gasoline to support the operation and mobility of official vehicles used for academic, administrative, logistical, and official functions of the campus.	Small Value Procurement	No	N/A	January 2027	December 2027	GOP	95,000.00		
Procurement of Textbooks and Instructional Materials	HES	This project involves the procurement of textbooks, reference books, manuals, and other instructional materials necessary to support quality teaching and learning across academic programs.	Small Value Procurement	No	N/A	September 2027	October 2027	GOP	350,000.00		
Provision for the Repair and Maintenance of Buildings	HES	This project covers the procurement of labor, materials, supplies, and related services necessary for the repair, rehabilitation, and preventive maintenance of buildings and other physical facilities.	Small Value Procurement	No	N/A	June 2027	July 2027	GOP	150,000.00		
Provision for the Repair and Maintenance of Motor Vehicle	GAS	This project involves the procurement of services, labor, parts, and supplies necessary for the regular upkeep, repair, and preventive maintenance of the institution's motor vehicles.	Small Value Procurement	No	N/A	January 2027	December 2027	GOP	100,000.00		
Procurement of internet subscription services	GAS	Procurement of internet subscription services to ensure reliable and continuous connectivity for online transactions, communications, and other operational requirements of the campus.	Small Value Procurement	No	N/A	August 2027	September 2027	GOP	38,000.00		

TECHNOLOGICAL UNIVERSITY OF THE PHILIPPINES - CAVITE

ANNUAL PROCUREMENT PLAN FOR FY 2027

INDICATIVE
 FINAL
 UPDATED [Version No. 1]

PROCUREMENT PROJECT DETAILS						PROJECTED TIMELINE (MM/YYYY)		FUNDING DETAILS		PROCUREMENT STRATEGY OR TOOLS	REMARKS (Other relevant descriptions of the procurement project, if applicable)
Project Title	End-User or Implementing Unit	General Description of the Project	Mode of Procurement	To be covered by an Early Procurement Activity? (Yes/No)	Criteria for Bid Evaluation (Including Sustainability and Domestic Preference)	Start of Procurement Activity	End of Procurement Activity	Source of Fund	Estimated Budget / Approved Budget for the Contract (Php)		
Column 1	Column 2	Column 3	Column 4	Column 5	Column 6	Column 7	Column 8	Column 9	Column 10	Column 11	Column 12
General Requirements											
Provision for Postage/Courier Services	GAS	This project covers the procurement of postage, courier, and delivery services required to facilitate the timely and secure transmission of official documents, communications, and materials to various stakeholders.	Small Value Procurement	No	N/A	January 2027	December 2027	GOP	44,000.00		
Acquisition of Telecommunication/Landline & Mobile Services	GAS	This project involves the procurement of telecommunication services, including landline and mobile to support the institution's communication and coordination needs.	Small Value Procurement	No	N/A	January 2027	December 2027	GOP	217,000.00		
Provision for rental of Photocopier machine	GAS	This project covers the rental of photocopier machines required to support the institution's administrative and finance document reproduction needs. It includes the provision of units, maintenance services, and basic consumables necessary for efficient day-to-day operations.	Small Value Procurement	No	N/A	January 2027	December 2027	GOP	240,000.00		
Provision for Fidelity Bond Premium	GAS	This project covers the procurement of fidelity bond premiums for accountable officers and employees responsible for handling cash, property, and other financial resources of the institution.	Agency-to-Agency	No	N/A	January 2027	December 2027	GOP	60,000.00		
Auditing Services	GAS	The audit aims to ensure compliance with existing government accounting standards, applicable laws, rules and regulations, and to assess the fairness and accuracy of financial reporting.	Small Value Procurement	No	N/A	January 2027	December 2027	GOP	10,000.00		

TECHNOLOGICAL UNIVERSITY OF THE PHILIPPINES - CAVITE

ANNUAL PROCUREMENT PLAN FOR FY 2027

INDICATIVE
 FINAL
 UPDATED [Version No. 1]

PROCUREMENT PROJECT DETAILS						PROJECTED TIMELINE (MM/YYYY)		FUNDING DETAILS		PROCUREMENT STRATEGY OR TOOLS	REMARKS (Other relevant descriptions of the procurement project, if applicable)
Project Title	End-User or Implementing Unit	General Description of the Project	Mode of Procurement	To be covered by an Early Procurement Activity? (Yes/No)	Criteria for Bid Evaluation (Including Sustainability and Domestic Preference)	Start of Procurement Activity	End of Procurement Activity	Source of Fund	Estimated Budget / Approved Budget for the Contract (Php)		
Column 1	Column 2	Column 3	Column 4	Column 5	Column 6	Column 7	Column 8	Column 9	Column 10	Column 11	Column 12
General Requirements											
Provision for Travelling Expenses for official local and foreign travel	ALL SECTORS	This project covers the provision and utilization of funds for official local and foreign travel, including transportation expenses, per diems, accommodation, and other necessary incidental costs incurred by employees in the performance of their official duties.	Small Value Procurement	No	N/A	January 2027	December 2026	GOP	779,000.00		
Provision for Training Expenses for personnel	ALL SECTORS	This project covers the provision of funds for training, seminars, workshops, and capacity-building activities for personnel to enhance their knowledge, skills, and competencies. It includes expenses related to registration fees, resource materials, venue, facilitators, and other necessary costs directly associated with the conduct of these programs.	Small Value Procurement	No	N/A	January 2027	December 2027	GOP	523,000.00		
Provision for representation expenses for the conduct of activities	ALL SECTORS	This project covers the allocation of funds for official representation purposes, including hosting meetings, receptions, and other official functions involving government officials, stakeholders, partners, or clients. It includes expenses for meals, tokens, and other necessary costs incurred to facilitate official engagements, promote institutional goodwill, and strengthen professional relationships.	Small Value Procurement	No	N/A	January 2027	December 2027	GOP	653,000.00		

TECHNOLOGICAL UNIVERSITY OF THE PHILIPPINES - CAVITE

ANNUAL PROCUREMENT PLAN FOR FY 2027

INDICATIVE
 FINAL
 UPDATED [Version No. 1]

PROCUREMENT PROJECT DETAILS						PROJECTED TIMELINE (MM/YYYY)		FUNDING DETAILS		PROCUREMENT STRATEGY OR TOOLS	REMARKS (Other relevant descriptions of the procurement project, if applicable)
Project Title	End-User or Implementing Unit	General Description of the Project	Mode of Procurement	To be covered by an Early Procurement Activity? (Yes/No)	Criteria for Bid Evaluation (Including Sustainability and Domestic Preference)	Start of Procurement Activity	End of Procurement Activity	Source of Fund	Estimated Budget / Approved Budget for the Contract (Php)		
Column 1	Column 2	Column 3	Column 4	Column 5	Column 6	Column 7	Column 8	Column 9	Column 10	Column 11	Column 12
General Requirements											
Provision for Extraordinary and Miscellaneous Expenses	ALL SECTORS	This project covers the allocation of funds for unforeseen, irregular, or incidental expenses that may arise in the course of institutional operations and are not included under other specific budgetary items. It includes costs necessary to address urgent, exceptional, or extraordinary situations that require immediate attention to ensure the continuity of services, compliance with regulations, and the efficient functioning of the institution.	Small Value Procurement	No	N/A	January 2027	December 2027	GOP	102,000.00		
Provision for Water Supply Services	GAS / HES	This project covers the procurement for water supply services required for the daily operations of the institution. It includes expenses for potable water consumption in offices, laboratories, classrooms, and other facilities, ensuring adequate provision for administrative, academic, and operational needs.	Small Value Procurement	No	N/A	January 2027	December 2027	GOP	612,000.00		
Provision for Electricity Services	GAS / HES	This project covers the procurement of electricity consumption necessary to support the day-to-day operations of the institution. It includes the cost of power supply for offices, classrooms, laboratories, and other facilities, ensuring uninterrupted services for administrative, academic, and operational activities.	Small Value Procurement	No	N/A	January 2027	December 2027	GOP	3,687,203.00		
Miscellaneous Items (for Direct Acquisition only) Sec 32.2 of RA No. 12009											
Common Use Supplies and Equipment (CSE) to be purchased from PS-DBM (kindly indicate the summary/total amounts only)											

Note: Insert additional rows as necessary

Total Amount of Estimated Budget for EPA Projects:	6,400,000.00
Total Amount of CSEs to be purchased from PS-DBM:	0
Total Amount of Estimated Budget:	6,400,000.00

TECHNOLOGICAL UNIVERSITY OF THE PHILIPPINES - CAVITE

ANNUAL PROCUREMENT PLAN FOR FY 2027

INDICATIVE
 FINAL
 UPDATED [Version No. 1]

TIER II

PROCUREMENT PROJECT DETAILS						PROJECTED TIMELINE (MM/YYYY)		FUNDING DETAILS		PROCUREMENT STRATEGY OR TOOLS	REMARKS (Other relevant descriptions of the procurement project, if applicable)
Project Title	End-User or Implementing Unit	General Description of the Project	Mode of Procurement	To be covered by an Early Procurement Activity? (Yes/No)	Criteria for Bid Evaluation (Including Sustainability and Domestic Preference)	Start of Procurement Activity	End of Procurement Activity	Source of Fund	Estimated Budget / Approved Budget for the Contract (PHP)		
Column 1	Column 2	Column 3	Column 4	Column 5	Column 6	Column 7	Column 8	Column 9	Column 10	Column 11	Column 12
General Requirements											
Procurement of Janitorial Services	GAS	Procurement contract for janitorial services is essential for the maintaining cleanliness and managing of school properties and community within the Campus premises.	Public Bidding	Yes	LCRB	October 2026	December 2026	GOP	2,550,709.00		
Procurement of Security Services	GAS	Procurement contract for security services is essential for the safety and security of school properties and community within the Campus premises.	Public Bidding	Yes	LCRB	October 2026	December 2026	GOP	3,402,956.00		
Insurance Expense	GAS	Procurement of insurance coverage for buildings and equipment to protect government properties against loss, damage, or other unforeseen risks and to ensure continuity of operations	Negotiated Procurement - Agency-to-Agency	No	N/A	February 2027	March 2027	GOP	1,000,000.00		
Acquisition of Telecommunication - Mobile Services	GAS	This project involves the procurement of telecommunication services, including mobile to support the institution's communication and coordination needs.	Small Value Procurement	No	N/A	January 2027	December 2027	GOP	17,000.00		
Construction of Campus Dormitory at TUP-Cavite (Phase II)	HES	The construction of Campus Dormitory at TUP Cavite (Phase I) is ongoing and is expected to be completed in the 2nd quarter of 2026. This project is a justified and crucial initiative aimed at addressing the residential needs of students and enhancing their overall campus experience. Recognizing the importance of providing students with a supportive environment for learning and personal development, especially for those from distant locations, the dormitory project offers well-designed living quarters and common areas.	Public Bidding	Yes	LCRB	October 2026	December 2026	GOP	75,000,000.00		

TECHNOLOGICAL UNIVERSITY OF THE PHILIPPINES - CAVITE

ANNUAL PROCUREMENT PLAN FOR FY 2027

INDICATIVE
 FINAL
 UPDATED [Version No. 1]

TIER II

PROCUREMENT PROJECT DETAILS						PROJECTED TIMELINE (MM/YYYY)		FUNDING DETAILS		PROCUREMENT STRATEGY OR TOOLS	REMARKS (Other relevant descriptions of the procurement project, if applicable)
Project Title	End-User or Implementing Unit	General Description of the Project	Mode of Procurement	To be covered by an Early Procurement Activity? (Yes/No)	Criteria for Bid Evaluation (Including Sustainability and Domestic Preference)	Start of Procurement Activity	End of Procurement Activity	Source of Fund	Estimated Budget / Approved Budget for the Contract (PHP)		
Column 1	Column 2	Column 3	Column 4	Column 5	Column 6	Column 7	Column 8	Column 9	Column 10	Column 11	Column 12
General Requirements											
Acquisition of Mini Steam Power Plant/Boiler for BSME program	HES	This is a specialized technical facility project comprising two main components: the acquisition of a Mini Steam Power Plant/Boiler, and the construction of a dedicated, safe Boiler Room to house this equipment. The definite purpose is to provide students in the BS Mechanical Engineering (BSME) program with high-fidelity, industrial-scale, hands-on training experience in energy generation, thermodynamics, and steam power operation. This facility will serve as a specialized laboratory for advanced practical instruction and technology utilization.	Public Bidding	Yes	LCRB	October 2026	December 2026	GOP	15,000,000.00		
Construction of Boiler Room at TUP Cavite Campus	HES		Public Bidding	Yes	LCRB	October 2026	December 2026	GOP	10,000,000.00		
Construction of Architecture and Engineering Building at TUP Cavite Campus (Phase I)	HES	This project is a vital undertaking aimed at creating a purpose-built facility tailored to the specific needs of architecture and engineering programs. Envisioned as a hub for academic excellence and innovation, the building's cutting-edge design incorporates specialized laboratories, CAD studios, and collaborative spaces to provide students and faculty with an environment conducive to theoretical learning, hands-on practical experience, and collaborative research.	Public Bidding	Yes	LCRB	October 2026	December 2026	GOP	77,500,000.00		
Renovation of Gymnasium at TUP Cavite Campus	HES	This is a project for the comprehensive renovation and upgrade of the existing campus gymnasium and related athletic/recreational facilities. The specific components include structural repairs, modernization of sporting equipment, improvement of safety features, and enhancement of ancillary facilities (e.g., locker rooms, seating areas) to meet modern standards. The facility's definite purpose is to provide a safe, functional, and enhanced venue for physical activity, health, and campus community engagement.	Public Bidding	Yes	LCRB	October 2026	December 2026	GOP	30,000,000.00		

TECHNOLOGICAL UNIVERSITY OF THE PHILIPPINES - CAVITE

ANNUAL PROCUREMENT PLAN FOR FY 2027

INDICATIVE
 FINAL
 UPDATED [Version No. 1]

TIER II

PROCUREMENT PROJECT DETAILS						PROJECTED TIMELINE (MM/YYYY)		FUNDING DETAILS		PROCUREMENT STRATEGY OR TOOLS	REMARKS (Other relevant descriptions of the procurement project, if applicable)
Project Title	End-User or Implementing Unit	General Description of the Project	Mode of Procurement	To be covered by an Early Procurement Activity? (Yes/No)	Criteria for Bid Evaluation (Including Sustainability and Domestic Preference)	Start of Procurement Activity	End of Procurement Activity	Source of Fund	Estimated Budget / Approved Budget for the Contract (PhP)		
Column 1	Column 2	Column 3	Column 4	Column 5	Column 6	Column 7	Column 8	Column 9	Column 10	Column 11	Column 12
General Requirements											
Acquisition of 1 Unit Electric PUV under Green Public Procurement for Sustainable and Equitable Campus Mobility	HES	This project focuses on the strategic Green Procurement of one (1) unit of the Electric PUV Class 2 Battery Electric Vehicle (BEV) to launch a pilot low-emission, high-capacity transport service. The procurement aligns with the PDP's strategy to strengthen green public procurement and increase the adoption of e-vehicles to reduce transport costs and GHG emissions. The components include the BEV unit (featuring specialized energy-efficient air conditioning and a regenerative braking system) and the necessary charging infrastructure. The definite purpose is to transition the campus fleet towards low-carbon technology and establish an affordable, reliable, and inclusive transport service for students and employees for official business.	Public Bidding	Yes	LCRB	October 2026	December 2026	GOP	3,500,000.00		
Miscellaneous Items (for Direct Acquisition only) Sec 32.2 of RA No. 12009											
Common Use Supplies and Equipment (CSE) to be purchased from PS-DBM (kindly indicate the summary/total amounts only)											

Note: Insert additional rows as necessary

Total Amount of Estimated Budget for EPA Projects:	5,953,665.00
Total Amount of CSEs to be purchased from PS-DBM:	0
Total Amount of Estimated Budget:	5,953,665.00

TECHNOLOGICAL UNIVERSITY OF THE PHILIPPINES - CAVITE

ANNUAL PROCUREMENT PLAN FOR FY 2027

INDICATIVE
 FINAL
 UPDATED [Version No. 1]

PROCUREMENT PROJECT DETAILS						PROJECTED TIMELINE (MM/YYYY)		FUNDING DETAILS		PROCUREMENT STRATEGY OR TOOLS	REMARKS (Other relevant descriptions of the procurement project, if applicable)
Project Title	End-User or Implementing Unit	General Description of the Project	Mode of Procurement	To be covered by an Early Procurement Activity? (Yes/No)	Criteria for Bid Evaluation (Including Sustainability and Domestic Preference)	Start of Procurement Activity	End of Procurement Activity	Source of Fund	Estimated Budget / Approved Budget for the Contract (Php)		
Column 1	Column 2	Column 3	Column 4	Column 5	Column 6	Column 7	Column 8	Column 9	Column 10	Column 11	Column 12

Prepared by:

Recommended by:
By the Authority of the Bids and Awards Committee:

Approved by:



ENGR. RAMON CHRISTOPHER H. ESCALONA
Bids and Awards Committee Secretariat



DR. EMILY L. BELTRAN
Bids and Awards Committee Chairperson

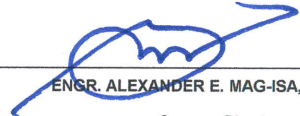

ENGR. ALEXANDER E. MAG-ISA, PhD., PME
Campus Director

Date : _____

Date : _____

Date : _____



CAPITAL OUTLAY PROPOSAL FY 2027



TABLE OF CONTENTS CAPITAL OUTLAY

- A. Construction of Campus Dormitory at TUP Cavite (Phase II)**
 - A.1** RDIP Project Profile
 - A.2** DENR Clearance
 - A.3** Feasibility Study
 - A.4** Architectural Design
 - A.5** Electrical Design
 - A.6** Structural Design
 - A.7** Plumbing Design
 - A.8** Program of Works
 - A.9** Detailed Scope of Works

- B. Acquisition of Mini Steam Power Plant/Boiler for BSME Program and Construction of Boiler Room at TUP Cavite Campus**
 - B.1** RDIP Project Profile
 - B.2** Justification
 - B.3** Detailed Engineering Design
 - B.4** Program of Works

- C. Construction of Architecture and Engineering Building at TUP Cavite (Phase I)**
 - C.1** RDIP Project Profile
 - C.2** Feasibility Study
 - C.3** Detailed Engineering Design
 - C.4** Program of Works
 - C.5** Detailed Scope of Works

- D. Renovation of Gymnasium at TUP Cavite Campus**
 - D.1** RDIP Project Profile
 - D.2** Detailed Engineering Design
 - D.3** Program of Works

- E. Acquisition of Electric PUV under Green Public Procurement for Sustainable and Equitable Campus Mobility**
 - RDIP Project Profile
 - Justification



CONSTRUCTION OF CAMPUS DORMITORY AT TUP CAVITE (PHASE II)



TUPC DORMITORY RDIP PROJECT PROFILE



**REGIONAL DEVELOPMENT COUNCIL
NATIONAL CAPITAL REGION (RDC-NCR)**

“Where Metro Manila goes, so the country goes”

FORMULATION OF THE REGIONAL DEVELOPMENT INVESTMENT PROGRAM FOR THE NATIONAL CAPITAL REGION (RDIP-NCR) 2023-2028

IMPLEMENTING AGENCY: TECHNOLOGICAL UNIVERSITY OF THE PHILIPPINES CAVITE CAMPUS

CO-IMPLEMENTING AGENCY: NA

FOCAL PERSON: ATTY. DANILO M. ABAYON/OIC-Campus Director

CONTACT DETAILS: Carlos Q. Trinidad Avenue, Salawag, Dasmariñas City, Cavite/ (046) 416-4920

PROJECT PROFILE	
A. GENERAL INFORMATION	
TITLE	Construction of Campus Dormitory at TUP Cavite Campus (Phase 2)
PROGRAM¹ OR PROJECT²	<input type="checkbox"/> Program <i>Is it a regular program?³</i> <input type="checkbox"/> Yes ✓ <input type="checkbox"/> No <input checked="" type="checkbox"/> Project <i>Is this part/included in your Central Office's Public Investment Program (PIP)?</i> <input checked="" type="checkbox"/> Yes <input type="checkbox"/> No
STATUS	<input type="checkbox"/> Ongoing ⁴ <input checked="" type="checkbox"/> Proposed <input type="checkbox"/> Pipeline <input type="checkbox"/> Completed
DESCRIPTION	This project involves the construction of Phase 2 of the campus dormitory, resulting in additional, essential residential facilities for TUP students. The components include well-designed living quarters (dorm rooms), common areas, study halls, and other amenities required for a safe and supportive student residential environment. The definite purpose is to upgrade the built environment of the campus by providing affordable and secure on-campus housing, particularly for non-local and vulnerable students.
OBJECTIVES	The project aims to address the gap in adequate and inclusive student housing, which currently limits access to safe and affordable accommodation for non-local and financially challenged students. By expanding on-campus residential capacity, the project supports the PDP objective of fostering a more inclusive, learner-centered, and enabling environment that enhances educational outcomes. The dormitory's Phase 2 development contributes to building a supportive learning ecosystem that promotes higher student retention, improved academic performance, and overall well-being—advancing the PDP

¹ A program is a group of activities and projects that contribute to a common particular outcome. A program should have the following: a) unique expected results or outcomes; b) clear target population or client group external to the agency; c) defined method of intervention to achieve the desired result; and d) a clear management structure that defines accountabilities.

² A project is a special undertaking carried out within a definite timeframe and intended to result in some pre-determined measure of goods and services.

³ Refers to a program being implemented on a regular basis. For regular programs, only the investment targets covering 2023-2028 shall be submitted.

⁴ Ongoing P/Ps are considered ongoing if they satisfy any of the following: (a) if locally funded - upon issuance of notice to proceed; (b) if Official Development Assistance (ODA)-assisted - upon effectivity of loan or grant agreement; and (c) if PPP or Joint Venture (JV)- upon signing of concession/JV agreement including unsolicited PPP P/Ps.

PROJECT PROFILE		
	outcome on globally competitive and inclusive TVET and higher education, with improved research output for a broader knowledge economy.	
COMPONENTS	The dormitory comprises several essential components meticulously designed to provide a conducive living environment for students. The ground floor is intelligently divided into three major sections: the common area, the girl's area, and the boy's area. The common area encompasses crucial facilities such as the lobby, waiting area, stairs, elevator, laundry room, and two toilets. Within the girl's and boy's areas, there are four rooms each, accommodating three double-deck beds, three study desks, two restrooms, and one shower area. The second floor offers eight rooms, capable of housing a total of forty-eight students. Each room features three double-deck beds, three study desks, and its own bathroom with two toilets, one shower area, and a sink area. Divided into girls' and boys' sections, this floor also includes a mess hall, a kitchen area, and designated fire exits. The third floor expands the dormitory's capacity, with nine rooms accommodating fifty students and five guest rooms with queen-sized beds. Each room on this floor includes its own toilet and bath with a sink area, and communal spaces like an entertainment area and lobby cater to the residents' needs. The fourth floor introduces a conference room, and an adjacent roof deck provides additional functionality. These meticulously planned components of the dormitory aim to create a supportive and well-equipped living space for students at TUP-Cavite, enhancing their overall campus experience.	
LOCATION/SCOPE	Carlos Q. Trinidad Avenue, Salawag, Dasmariñas City, Cavite	
IMPLEMENTATION PERIOD	Start of implementation: 1 st quarter of 2026 End of implementation: 4 th quarter of 2026	
EXPECTED OUTPUTS	The expected outputs include the creation of a sense of community among students, facilitated by communal spaces and amenities that foster social interaction. With the provision of convenient housing options, the dormitory aims to ease the accommodation challenges faced by students, enhancing their overall campus experience. As a vital component of campus infrastructure, this construction project aligns with TUP's commitment to ensuring a holistic and enriching educational environment. The tangible outputs, therefore, include well-equipped living quarters, common areas conducive to community building, and a convenient housing option that collectively contribute to an enhanced and supportive educational atmosphere at TUP-Cavite.	
LEVEL OF GAD RESPONSIVENESS⁵	<input type="checkbox"/> GAD is invisible in the program/project <input type="checkbox"/> Program/Project has promising GAD prospects <input type="checkbox"/> Program/Project is gender-sensitive <input checked="" type="checkbox"/> Program/Project is gender-responsive	
B. PROJECT FINANCING		
FINANCING SOURCE	<input checked="" type="checkbox"/> NG-Local <input type="checkbox"/> ODA Loan <input type="checkbox"/> ODA Grant <input type="checkbox"/> Internally-generated fund (for GOCCs/GFIs) <input type="checkbox"/> Private Sector <input type="checkbox"/> Others: Please specify, _____	
YEAR	Amount (separate columns per funding source, if applicable)	
	GAA/Internal Funds	Other Funding Source/s
2023	-	-

⁵ Identify the Level of GAD Responsiveness of the program/project based on the score of the program/project using the appropriate Gender and Development (GAD) checklist (<https://neda.gov.ph/gender-and-development/>).

PROJECT PROFILE		
2024	-	-
2025	-	-
2026	-	-
2027	75,000,000	-
2028	-	-
Continuing Years	-	-
Total (2023-2028)	75,000,000	-
TOTAL PROJECT COST	75,000,000	-
C. TYPOLOGY		
TYPE OF P/P	<input type="checkbox"/> Major Capital Investment Program and Project <input type="checkbox"/> Technical Assistance Program/Project (such as Research and Development, Institutional Development, Human Resource Capacity Building, or System/Process Improvement PAPs) <i>Is the Technical Assistance Program/Project considered a Research and Development Program/Project?</i> <input type="checkbox"/> Yes <input type="checkbox"/> No <input type="checkbox"/> Relending Program/Project of GFIs to LGUs and Target Beneficiary <input checked="" type="checkbox"/> Government Facilities used as an office, housing, and other technical purposes	
D. READINESS		
PROJECT PREPARATION DOCUMENT ACCOMPLISHED	<input checked="" type="checkbox"/> Feasibility Study F/S Cost (in exact PHP amount). _____ <i>Status:</i> <input checked="" type="checkbox"/> Completed <input type="checkbox"/> -Ongoing. Expected Completion Date: _____ <input type="checkbox"/> For Preparation. Start Date: _____ <input type="checkbox"/> Business Case <input type="checkbox"/> Project Proposal <input type="checkbox"/> Concept Note <input type="checkbox"/> Project Idea <input type="checkbox"/> Others: Detailed Engineering Design, Program of Works, and Scope of Works	
APPROVALS	<input type="checkbox"/> RDC-NCR Approval <i>Date of Approval:</i> _____ <input type="checkbox"/> ICC/NEDA Board Approval not required Approval/s Secured: _____ Date of Approval: _____ Approval/s Required: _____ Target Date of Approval: _____ <input type="checkbox"/> ICC/NEDA Board Approval required <i>Status of ICC/NEDA Board Approval?</i> <input type="checkbox"/> Yet to be submitted to NEDA Secretariat Target Date of Submission: _____ <input type="checkbox"/> Under the NEDA Secretariat Review Date of Submission to NEDA Secretariat: _____ <input type="checkbox"/> ICC-TB Endorsed	

PROJECT PROFILE			
	Date of Endorsement: _____ ICC-CC Approved Date of Approval: _____ NEDA Board Confirmed Date of Approval: _____		
LEVEL OF READINESS	<input type="checkbox"/> Level 1: With the approval of appropriate authority ⁶ but not yet ongoing <input type="checkbox"/> Level 2: Project preparation document completed; For the approval of appropriate approving body in 2022 or 2023 and for inclusion in the NEP for FY 2023 <input checked="" type="checkbox"/> Level 3: Project preparation document currently being prepared and to be completed in 2023; for approval in 2024 and for inclusion in the NEP for FY 2025		
FOR ONGOING P/Ps			
PHYSICAL ACCOMPLISHMENT	NA		
FINANCIAL ACCOMPLISHMENT			
Year	Amount Included/for Inclusion in the NEP	Amount Allocated in the Budget/GAA	Actual Amount Disbursed
2023	-	-	-
2024	-	-	-
2025	-	-	-
2026	-	-	-
2027	75,000,000	-	-
2028	-	-	-
E. PROJECT/PROGRAM VIABILITY			
Project benefits	<p><i>The construction of Campus Dormitory at TUP-Cavite is anticipated to yield positive economic and financial returns, along with substantial social and environmental benefits. The focus on establishing essential dormitory facilities, providing well-designed living quarters, and creating common areas aligns with TUP's commitment to ensuring a holistic and enriching educational environment. The provision of a supportive living space is particularly valuable for students hailing from distant locations, fostering personal development and a sense of community. In terms of economic and financial metrics, a competitive Internal Rate of Return (IRR), potentially ranging from 10-15% or higher, is expected, reflecting the long-term benefits associated with a thoughtfully designed living space for students. Similarly, a Benefit-Cost Ratio (BCR) greater than 1 is anticipated, indicating that the benefits of the project exceed the associated costs. Moreover, the project's incorporation of individual and communal spaces, amenities for social interaction, entertainment spaces, and additional support areas contributes to its potential social benefits. While the primary focus is on student welfare, the project may also consider sustainable practices in construction and operations, contributing to environmental responsibility.</i></p>		

⁶Please attach a copy of approval

PROJECT PROFILE

Prepared by:



DARIUS L. FAJARDO
Planning Officer
March 02 2026

Approved by:

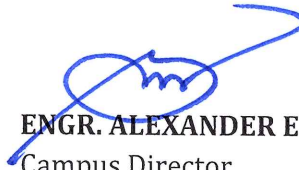

ENGR. ALEXANDER E. MAG-ISA
Campus Director
March 02, 2026

(as of June 26, 2023)



TUPC DORMITORY DENR CLEARANCE



Republic of the Philippines
Department of Environment and Natural Resources
MINES AND GEOSCIENCES BUREAU
Regional Office No. IV CALABARZON
8TH Floor, DENR by the Bay Building, Roxas Boulevard
Ermita, Manila, Philippines
Telefax. No. (+632) 5310-88-97 E-mail: region4a@mgb.gov.ph
Website: region4a.mgb.gov.ph



Certificate No. 66832
EAC Code: 36

November 2, 2023

MS. MYRNA M. TEPORA, Ph.D
Campus Director
Technological University of the Philippines
Cavite Campus
Carlos Q. Trinidad Avenue, Salawag,
4114 Dasmariñas City, Cavite

Dear Ms. M. M. Tepora, Ph.D:

This refers to the electronic mail dated 12 October 2023 which was received by this Office October 18, 2023 requesting from this Office a Clearance/Certification for the proposed project listed below.

After the submission of the geographical coordinates of the project areas last 24 October 2023, our evaluation of the project areas shows that their susceptibility ratings to rain-induced landslides and flooding are as follows:

PROJECT/LOCATION	QUADRANGLE NUMBERS/NAMES	SUSCEPTIBILITY RATING	
		LANDSLIDE	FLOOD
1. Six (6)-Storey Engineering and Architecture Building located at TUP Campus, Barangay Salawag, Dasmariñas City, Cavite. (14. 345183° North Latitude and 120.966514 East Longitude) (WGS 1984)	3129-I-20 SALAWAG	Low	Low
2. Four (4)-Storey TUPC Dormitory Building located at TUP Campus, Barangay Salawag, Dasmariñas City, Cavite. (14. 346390° North Latitude and 120.966364° East Longitude) (WGS 1984)		Low	Low

"MINING SHALL BE PRO-PEOPLE AND PRO-ENVIRONMENT
IN SUSTAINING WEALTH CREATION AND IMPROVED QUALITY OF LIFE"

2023-23 3-27

Attached is a copy of the composite landslide and flood hazard map, for your reference.

In lieu of Clearance/Certification, we are issuing you a Geohazard Certification stating the susceptibility ratings of the proposed site to rain induced landslide and flood hazards.

Please be informed that this certification shall not exempt the developer/proponent from securing other documents related to land development and housing projects nor be utilized as a replacement for Geohazard Assessment Report (GAR) and Engineering Geological and Geohazard Assessment Report (EGGAR).

Other types of geohazards, such as earthquake-related and volcanic hazards should also be considered to determine comprehensively the suitability of the project sites. The assessment for earthquake-related and volcanic hazards may be requested from the Philippine Institute of Volcanology and Seismology or PHIVOLCS.

This Letter **serves as the Certification** being requested.

Thank you.

Very truly yours,

EDGARDO D. CASTILLO
Chief, Mine Management Division and
OIC, Regional Director in Concurrent Capacity

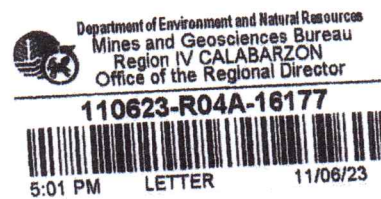



DETAILED LANDSLIDE AND FLOOD HAZARD MAP OF DASMARIÑAS AND GENERAL MARIANO ALVAREZ, CAVITE, PHILIPPINES 3129-I-20 SALAWAG QUADRANGLE

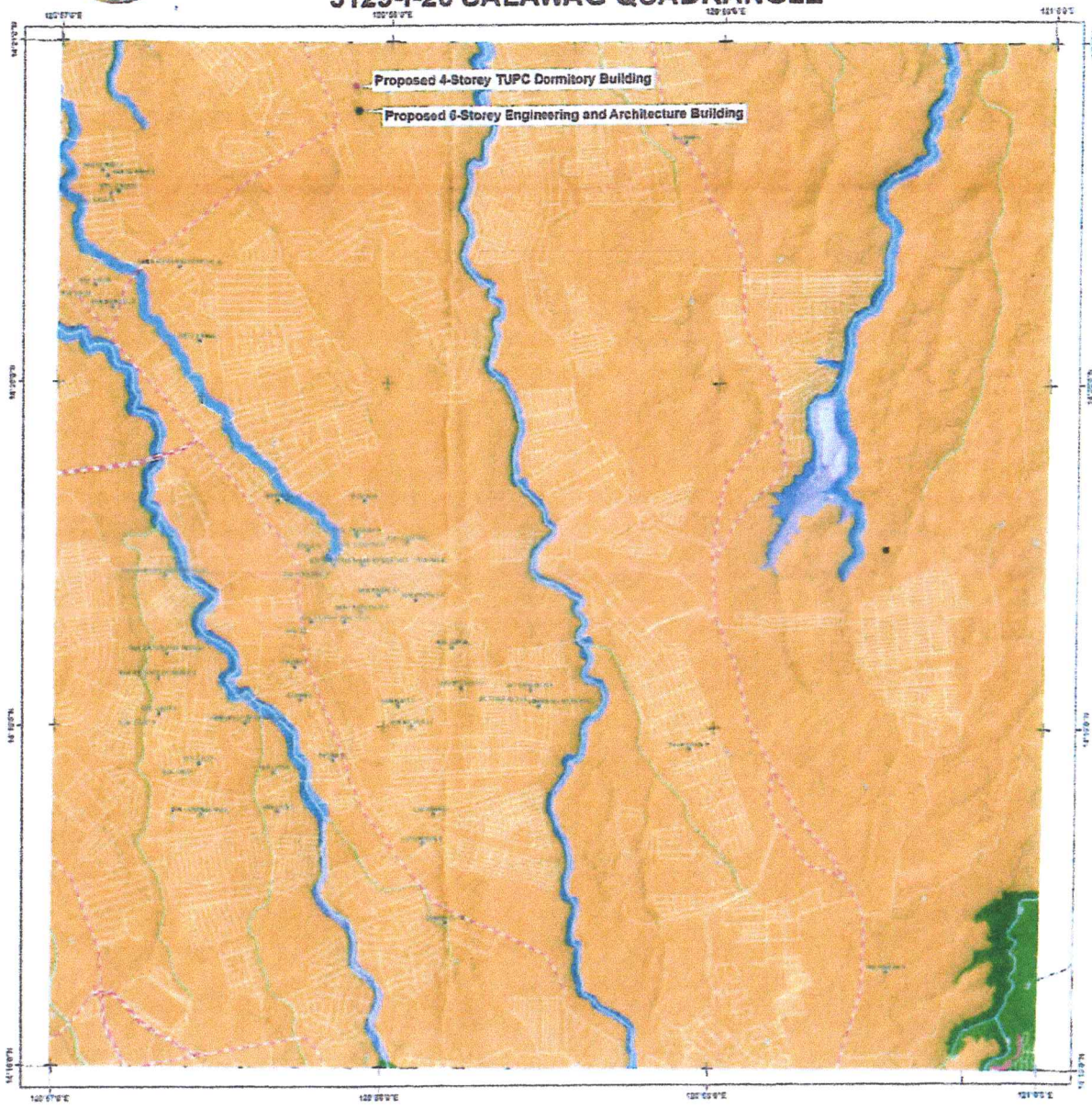
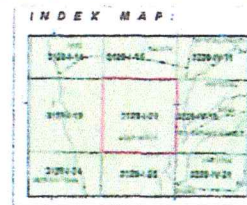

LEGEND :

- Main road
- Secondary road
- Track trail
- River
- Municipal boundary
- Contour (meter)
- Barangay center location
- Purok Office location (Barangay)
- School
- Hospital
- Church
- Proposed location of bus

Landslide

- Very High landslide susceptibility**
Areas usually with steep to very steep slopes and unstable by weak materials. Recurrent landslides, exceptments and forest-protection measures. Human-induced effects could be an aggravating factor.
- High landslide susceptibility**
Areas usually with steep to very steep slopes and underlain by weak materials. Areas with numerous old inactive landslides.
- Moderate landslide susceptibility**
Areas with moderately steep slopes. Soil creep and other indications of possible landslide occurrence are present.
- Low landslide susceptibility**
Gently sloping areas with no identified landslide.
- Debris flow / Possible accumulation zone**
Areas that could be affected by landslide debris.
- Active landslide
- Inactive landslide
- Landslide area with mitigating measure
- Rock fall/Rock slide prone area
- Old landslide deposits
- Recent landslide deposits
- Areas susceptible to ground subsidence/sinkhole development
- Creep
- Tension crack
- Gully
- Riverbank erosion

Flood

- Very High flood susceptibility**
Areas likely to experience flood heights of greater than 2 meters and/or flood duration of more than 3 days. These areas are immediately flooded during heavy rains of several hours. include landforms of topographic lows such as stream bed, channels, abandoned river channels and areas along river banks. also prone to flash floods.
- High flood susceptibility**
Areas likely to experience flood heights of greater than 1 up to 2 meters and/or flood duration of more than 3 days. These areas are immediately flooded during heavy rains of several hours. include landforms of topographic lows such as stream bed, channels, abandoned river channels and areas along river banks. also prone to flash floods.
- Moderate flood susceptibility**
Areas likely to experience flood heights of greater than 0.5m up to 2 meters and/or flood duration of 1 to 3 days. These areas are subjected to widespread inundation during prolonged and extreme heavy rainfall or extreme weather condition. River terraces, alluvial fans, and infilled valleys are areas moderately susceptible flooding.
- Low flood susceptibility**
Areas likely to experience flood heights of 0.5 meter or less and/or flood duration of less than 1 day. These areas include low hills and gentle slopes. They also have sparse to moderate drainage density.
- Direction of rising floodwater
- Direction of receding floodwater
- Flood depth (meter)
- Flood extent point

DEPARTMENT OF ENVIRONMENT AND NATURAL RESOURCES
MINES AND GEOSCIENCES BUREAU
North Avenue, Diliman, Quezon City

Data Sources :
MGB Geohazard Assessment Team
Lands Geological Survey Division
Geoscientific Division / MGB Regional Office (I/II)
National Mapping and Resources Information Authority

GIS Processing :
Lands Geological Survey Division

Coordinate System :
Spheroid
Projection
Datum
Clark 1966
Transverse Mercator
Luzon 1911

Mapping scale : 1 : 10,000

2.5 MILLIMETER SCALE
PHOTO COPY OF ORIGINAL



TUPC DORMITORY FEASIBILITY STUDY



REPUBLIC OF THE PHILIPPINES
TECHNOLOGICAL UNIVERSITY OF THE PHILIPPINES
CAVITE CAMPUS

Carlos Q. Trinidad Avenue, Salawag, Dasmariñas City, Cavite, Philippines
Telefax: (046) 416-4920
Email: cavite@tup.edu.ph | Website: www.tup.edu.ph



Management
System
ISO 9001:2015



www.tuv.com
ID 9108652185

**FEASIBILITY STUDY ON THE
PROPOSED CONSTRUCTION OF CAMPUS DORMITORY**

Darius L. Fajardo, Nicka Liezl L. Kwan, and Roberto L. Rodriguez Jr.

The proposed construction of a campus dormitory at the Technological University of the Philippines - Cavite Campus is the subject of this feasibility study. The proposed building's capabilities and capacities were defined based on its physical design in accordance with the Commission on Higher Education's policies, standards, and guidelines (CHED).

I. Campus History

The establishment of a campus of the Technological University of the Philippines (TUP) in Cavite was realized through the initiative of the Vice President for Administration Bayani Gutierrez under TUP President Jose Vergara, and was approved, by the Board of Regents on December 6, 1979 through Resolution No. 1895 s. 1979.

The establishment of the Cavite campus was in response to the demand for an institution of higher learning that can serve as an avenue for training technicians and skilled workers associated to the fast-growing industries in the region.

Technological University of the Philippines at Cavite (TUPC) stands on five-hectare land along Carlos Q. Trinidad Avenue in Salawag, Dasmariñas, Cavite, which was donated by the benevolent, Hon. Helena Benitez. A Memorandum of Agreement between TUP and the Philippine Women's University (PWU) dated February 14, 1981 stated, "PWU shall donate five (5) hectares of land to TUP, and TUP shall build facilities to house URC and such other facilities" abetted the realization of bringing Technology Education to Cavite.

Upon the release of the General Appropriations Act of 1981, Batas Pambansa 131, and the Deed of Donation in January 1982, operations in the Campus commenced with the following officials: Prof. Carlos Trinidad as Executive Director, Dr. Erlinda Manalang as Assistant Executive Director, Dr. Emeliana Tadeo as Academic Coordinator, Prof. Enrico Hilario as Technical Arts Coordinator, and Prof. Dominador Mendoza Jr. as Administrative Coordinator.

TUPC began its instruction to a pioneer group of 92 students on July 16, 1982 with 15 faculty members and 10 administrative staff. Initially, TUPC offered two-year Technician Education Programs in the areas of Civil Technology, Electrical Technology, Electronics Technology, Mechanical Technology and Automotive Technology. A year later, it added to its offerings on two-year Technical courses in Drafting Technology and Stationary Marine Engineering.

Through the dynamic leadership of Professor Trinidad and the strong support of, then, TUP President Frederick So Pada, major developments took place. More infrastructures were built to accommodate the growing student population, and the increasing number of faculty members and administrative staff. Degree programs were additionally offered to provide further professional growth and development of students who aspired to become teachers, engineers, technicians and skilled workers.



REPUBLIC OF THE PHILIPPINES
TECHNOLOGICAL UNIVERSITY OF THE PHILIPPINES
CAVITE CAMPUS

Carlos Q. Trinidad Avenue, Salawag, Dasmariñas City, Cavite, Philippines
Telefax: (046) 416-4920

Email: cavite@tup.edu.ph | Website: www.tup.edu.ph



Management System
ISO 9001:2015



www.tuv.com
ID 9108652185

After the demise of Prof. Trinidad in 1999, equally capable figures took the directorship in the Cavite Campus: Prof. Susan Nunez, Officer-in-Charge, 1997 and 1999; Prof. Enrico Hilario, Campus Director, 2000-2006; Dr. Olympio Caparas, Campus Director 2006-2007; Dr. Dionisio Espression Jr. 2007-2009; Dr. Myrna Tepora, Officer-in-Charge 2009; Dr. Reynaldo Jorda 2009-2010, Dr. Myrna Fernando in 2010-2014 and Dr. Andres Z. Taguiam 2014-2015.

The transition of the sound and effective leadership of the Campus Directors and other officials resulted in developments and transformation of the Cavite Campus into a recognized center of higher learning in the field of Technology Education. It became the home to competent industrial educators, skilled engineers and technologists in various institutions and industries in the local, national, and international level.

II. Geographical Description and Survey of the Site

The campus site development plan is depicted in Figure 1. The campus can use its printed and surveyed lot plan to plan and develop the site for future quality and responsive programs.

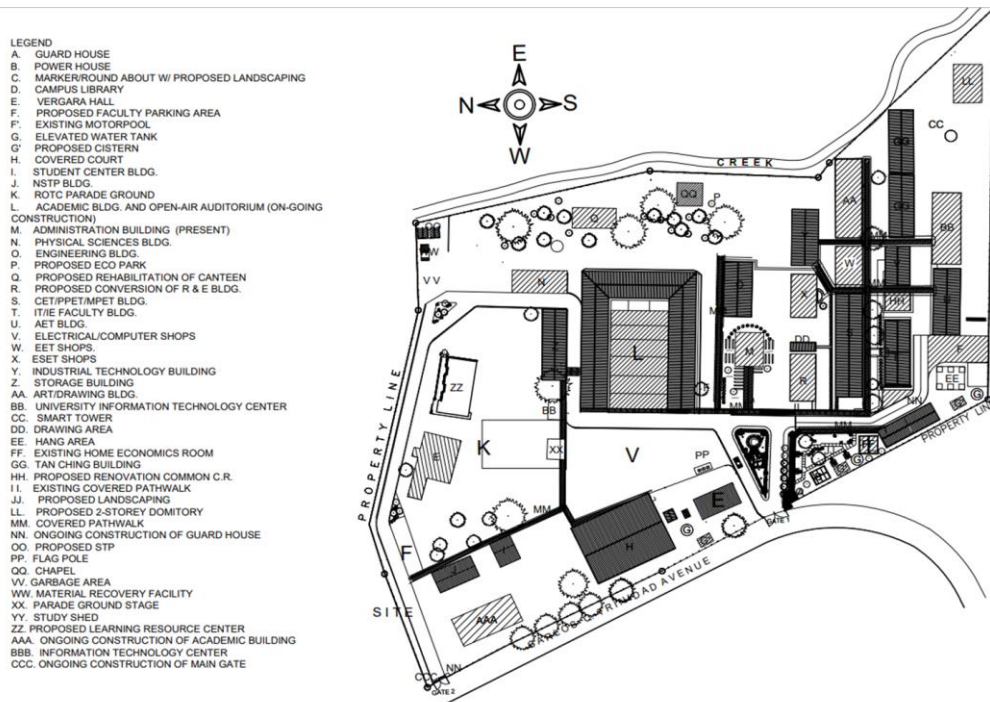

Figure 1 Site Development Plan

The 5-hectare land from which the campus facilities are planned is divided into six (6) zones, namely:

1. Academic zone;
2. Administrative zone;
3. Multipurpose activity zone;
4. Public zone;



REPUBLIC OF THE PHILIPPINES
TECHNOLOGICAL UNIVERSITY OF THE PHILIPPINES
CAVITE CAMPUS



Management System
 ISO 9001:2015



www.tuv.com
 ID 9108652185

Carlos Q. Trinidad Avenue, Salawag, Dasmariñas City, Cavite, Philippines
 Telefax: (046) 416-4920
 Email: cavite@tup.edu.ph | Website: www.tup.edu.ph

5. Utility/service zone; and
6. Private area zone

The estimated land area currently used for existing facilities and newly constructed buildings is 17,292.60 square meters, accounting for approximately 34% of the total area. The details of the estimated land area use and percentage share of total area by major buildings and other facilities in each zone are shown in Table 1.

Table 1

Existing Land Use by Zone

Name of Building/Structure	Land area (square meter)	Land use percent distribution
Academic zone		
NSTP/ROTC Building	271.395	0.53%
Academic Building	1,058.40	2.08%
Engineering Building	129.51	0.25%
R&E Building	527.06	1.03%
CET/PPET/MPET Building	424.08	0.83%
IT/IE Faculty Building	400	0.78%
AET Building	235.87	0.46%
EET/ESET Building	407.58	0.80%
EET Building	407.58	0.80%
ESET Building	151.93	0.30%
2-Storey 4-Classroom	134.96	0.26%
2-Storey 6-Classroom Building	171.625	0.34%
ART/Drawing Building	1,274.24	2.50%
Welding Shop	178.5	0.35%
4-Classroom Building	203.68	0.40%
Physics and Chemistry	400	0.78%
Academic Building	687.6	1.35%
Two-storey Learning Resource Center	403	0.79%
Total (Academic zone)	7,467.01	14.63%
Administrative zone		
SDWS Bldg.	182.45	0.36%
Administration Building	323.58	0.63%
Administrative Building (Newly-constructed)	546.91	1.07%
Total (Administrative zone)	1,052.94	2.06%
Multipurpose activity zone		
Covered Court	1,105.45	2.17%
Student Center Building	174.66	0.34%
ROTC Parade Ground	125	0.25%
Open Amphitheater	1,296.00	2.54%
Cooperative Store	15	0.03%
Infotech Building	203.64	0.40%
Information Technology Building	150	0.29%



REPUBLIC OF THE PHILIPPINES
TECHNOLOGICAL UNIVERSITY OF THE PHILIPPINES
CAVITE CAMPUS

Carlos Q. Trinidad Avenue, Salawag, Dasmariñas City, Cavite, Philippines

Telefax: (046) 416-4920

Email: cavite@tup.edu.ph | Website: www.tup.edu.ph



Management System
 ISO 9001:2015



www.tuv.com
 ID 9108652185

Name of Building/Structure	Land area (square meter)	Land use percent distribution
New gate 1	25	0.05%
Total (Multipurpose activity zone)	3,094.75	6.07%
Public zone		
Marker/Round About	200	0.39%
Covered Pathwalk	450	0.88%
Parking Area	750	1.47%
Proposed New Chapel with Landscapes	50	0.10%
Food Court	350	0.69%
Drawing Area	25	0.05%
Hang Area	100	0.20%
Common C.R.	162.63	0.32%
Comfort Room for Male and Female	50	0.10%
Flag Pole	50	0.10%
Main Road	3,000.00	5.88%
Total (Public zone)	5,187.63	10.17%
Utility/service zone		
Guard House	15	0.03%
Power House	225.27	0.44%
Elevated Water Tank	75	0.15%
material recovery facility (MRF)	75	0.15%
Total (Utility/service zone)	390.27	0.77%
Private area zone		
Smart Tower	100	0.20%
Total (Private area zone)	100	0.20%
Grand total land use	17,292.60	33.91%

III. The Private Area Zone

The private area zone currently occupies the smallest portion of land area of 100 square meters, equivalent to 0.2% of the total land area from which a Smart communication tower is erected. The campus hopes to construct a four-story dormitory for students and visitors in 2025 (with an estimated funding requirement of 75 million pesos). If this project is completed, an additional **480 square meters of land**, or 0.92%, will be used. Figure 2 shows the current proposed site for the construction of the aforementioned dormitory, which differs from the previous site in LUDIP.



REPUBLIC OF THE PHILIPPINES
TECHNOLOGICAL UNIVERSITY OF THE PHILIPPINES
CAVITE CAMPUS

Carlos Q. Trinidad Avenue, Salawag, Dasmariñas City, Cavite, Philippines
Telefax: (046) 416-4920
Email: cavite@tup.edu.ph | Website: www.tup.edu.ph



Management System
ISO 9001:2015



www.tuv.com
ID 9108652185

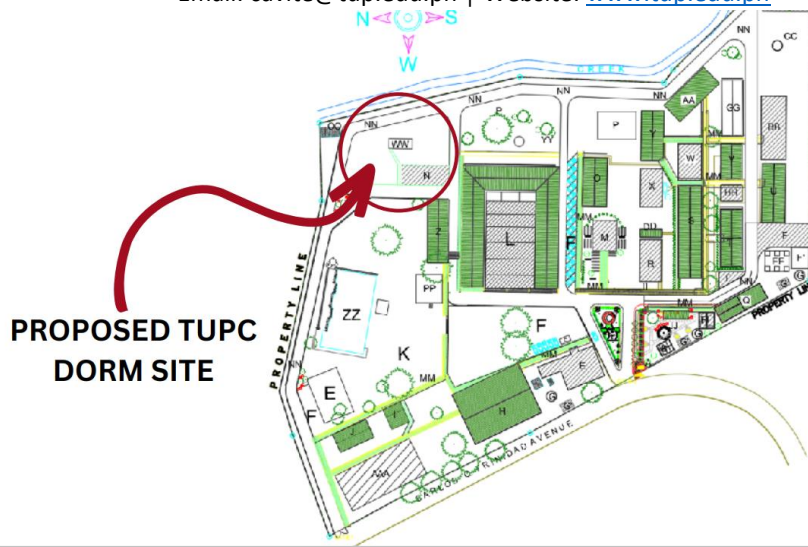

Figure 2 Proposed TUPC Dormitory Site

IV. Features and Capacities of the Proposed Dormitory



Figure 3 Perspective of the proposed dormitory

Figure 3 depicts the proposed four-story dormitory designed by the Infrastructure Development Office.



REPUBLIC OF THE PHILIPPINES
TECHNOLOGICAL UNIVERSITY OF THE PHILIPPINES
CAVITE CAMPUS

Carlos Q. Trinidad Avenue, Salawag, Dasmariñas City, Cavite, Philippines
 Telefax: (046) 416-4920
 Email: cavite@tup.edu.ph | Website: www.tup.edu.ph



Management System
 ISO 9001:2015



www.tuv.com
 ID 9108652185

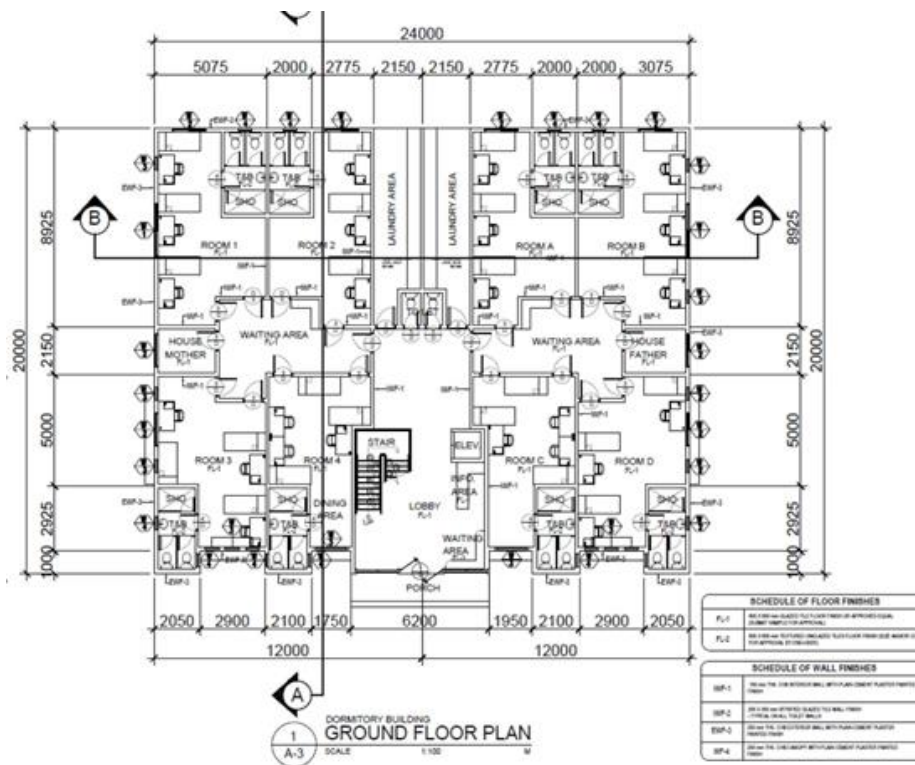

Figure 4 Ground Floor Plan

The ground floor of the building is divided into three major sections: the common area, the girl's area, and the boy's area. The common area includes the lobby, waiting area, stairs, elevator, laundry room, and two toilets. There are four rooms in the girl's and boy's areas, as well as a house mother room and a waiting area. Each room in the boy's and girl's areas can include three double beds, three study desks, two restrooms, and one shower area. Figure 4 shows the ground floor plan.



REPUBLIC OF THE PHILIPPINES
TECHNOLOGICAL UNIVERSITY OF THE PHILIPPINES
CAVITE CAMPUS

Carlos Q. Trinidad Avenue, Salawag, Dasmariñas City, Cavite, Philippines
Telefax: (046) 416-4920
Email: cavite@tup.edu.ph | Website: www.tup.edu.ph



Management System
ISO 9001:2015



www.tuv.com
ID 9108652185

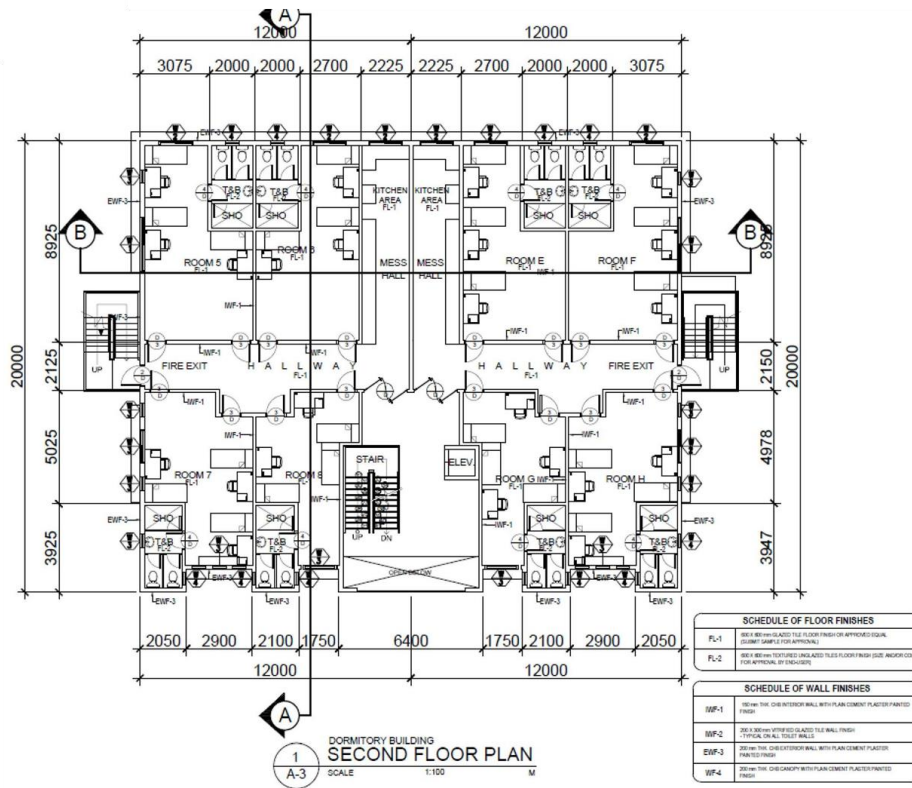

Figure 5 Second Floor Plan

The image above shows the second-floor plan of the proposed TUPC dormitory; with eight (8) rooms total that has a potential to house at least forty-eight (48) students. Each room can house six (6) students, with three (3) double-deck beds for utilization. Each room would also have three (3) study desks, its own bathroom – with two toilets, one shower area, and a sink area. The floor is divided into two sections, one for the girls’ area and the other for the boys. Each section would also feature a mess hall and a kitchen area. Designated fire exits are also present for emergency purposes. An elevator can be accessed from the lobby area of the floor.



REPUBLIC OF THE PHILIPPINES
TECHNOLOGICAL UNIVERSITY OF THE PHILIPPINES
CAVITE CAMPUS

Carlos Q. Trinidad Avenue, Salawag, Dasmariñas City, Cavite, Philippines
Telefax: (046) 416-4920
Email: cavite@tup.edu.ph | Website: www.tup.edu.ph



Management System
ISO 9001:2015



www.tuv.com
ID 9108652185

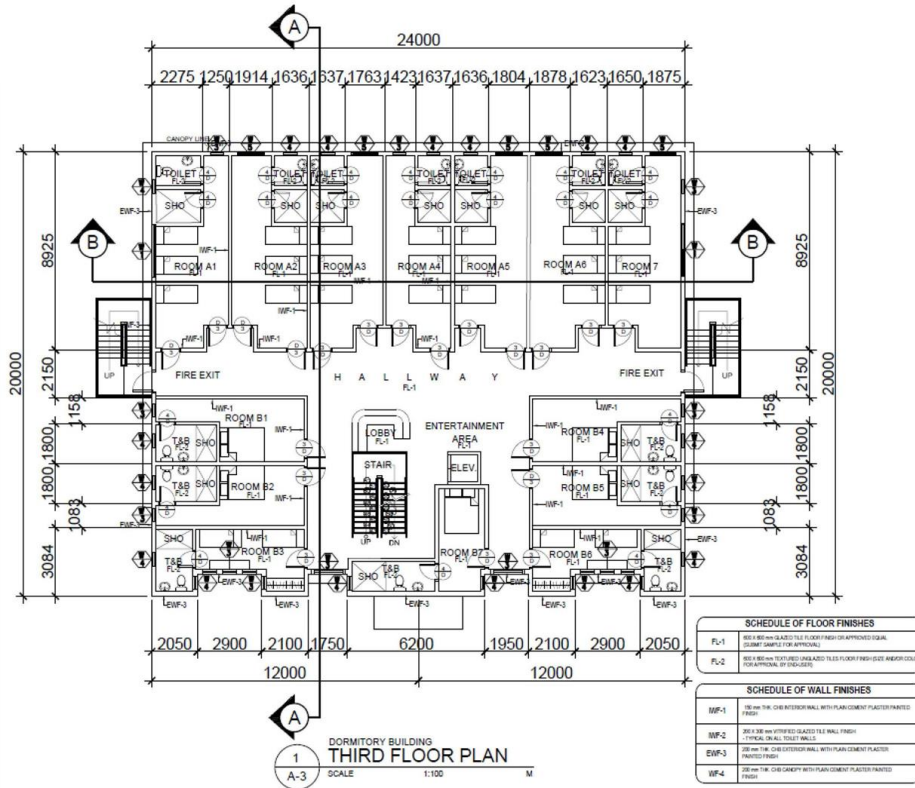

Figure 6 Third Floor Plan

The third-floor plan above shows nine (9) rooms for fifty (50) students, and five (5) guest rooms with a queen-sized bed. Each room on this floor has its own toilet and bath with a sink area. The third-floor area of the dormitory also features an entertainment area and a lobby area that could serve the residents of the floor.



REPUBLIC OF THE PHILIPPINES
TECHNOLOGICAL UNIVERSITY OF THE PHILIPPINES
CAVITE CAMPUS

Carlos Q. Trinidad Avenue, Salawag, Dasmariñas City, Cavite, Philippines
Telefax: (046) 416-4920
Email: cavite@tup.edu.ph | Website: www.tup.edu.ph



Management System
ISO 9001:2015



www.tuv.com
ID 9108652185

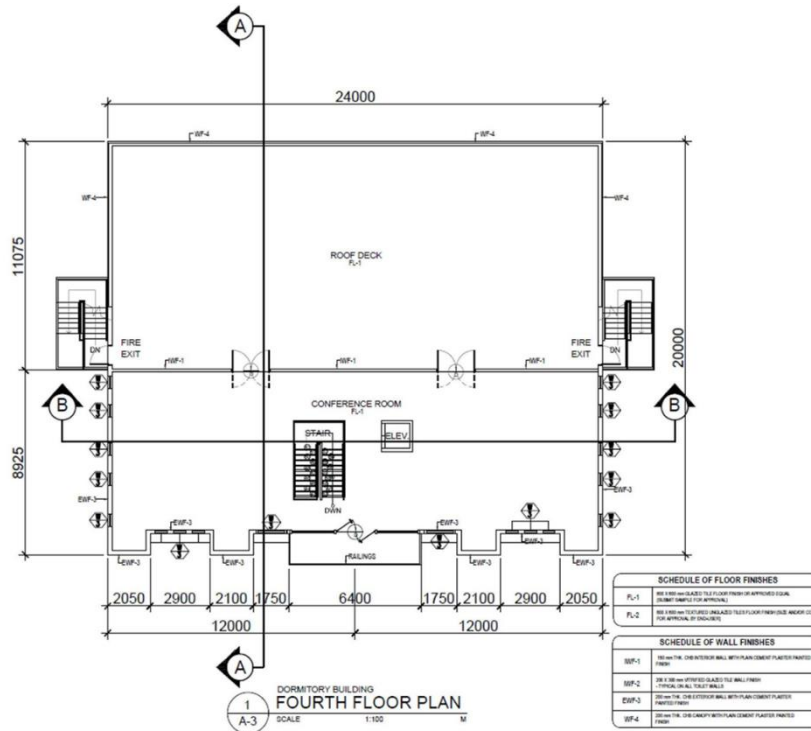

Figure 7 Fourth Floor Plan

Figure 7 shows the fourth-floor plan of the dormitory. A conference room is situated on this floor with a roof deck adjacent to it.



REPUBLIC OF THE PHILIPPINES
TECHNOLOGICAL UNIVERSITY OF THE PHILIPPINES
CAVITE CAMPUS

Carlos Q. Trinidad Avenue, Salawag, Dasmariñas City, Cavite, Philippines
 Telefax: (046) 416-4920
 Email: cavite@tup.edu.ph | Website: www.tup.edu.ph



Management System
 ISO 9001:2015
 www.tuv.com
 ID 9108652185



V. Students' Views about the Proposal and Congruency to CHED requirements

The Office of Campus Planning conducted a survey among students and employees in June 2022 to gather feedback on the plan to build a dormitory on campus. The information gathered from the respondents will serve as the foundation for management to determine whether or not the project is truly feasible.

The survey consists of 22 questions with the main goal of determining the respondents' current residence condition, degree of satisfaction with the services and living conditions in their current accommodation, and the respondents' interest to avail and live in a dormitory if one exists.

A total of 89 students responded to the survey. 53% of respondents live in Dasmariñas Cavite, 41% in neighboring Cavite provinces, and only 1% live outside of Cavite province. Table 3 depicts the frequency distribution of respondents' residence areas.

Table 3
 Frequency distribution of respondents' residence areas.

Current Residence area	Frequency	Percentage
Bacoor, Cavite	6	7%
Dasmariñas, Cavite	43	53%
General Trias, Cavite	6	7%
GMA, Cavite	1	1%
Imus, Cavite	8	9%
Indang, Cavite	3	3%
Las Pinas City	1	1%
Maragondon, Cavite	1	1%
Naic, Cavite	1	1%
Novelta, Cavite	1	1%
Rosario, Cavite	1	1%
Silang, Cavite	9	10%
Tanza, Cavite	2	2%
Trece Martirez City	2	2%

Sixty percent of respondents said that their current residence is far from the campus, and 84% use public transportation to get to school. According to table 4, the average daily travel expenses for those who use public transportation range between 100 and 200 pesos. However, 4 students still spend more than 300 pesos per day on commuting, which amounts to around 6500 pesos per month.

Table 4
 Daily travel expenses of students

Daily travel expenses	Frequency	Percentage
Less than 100 Php	22	25%
100-200 Php	46	52%
200-300 Php	16	18%
More than 300 Php	4	5%



REPUBLIC OF THE PHILIPPINES
TECHNOLOGICAL UNIVERSITY OF THE PHILIPPINES
CAVITE CAMPUS



Carlos Q. Trinidad Avenue, Salawag, Dasmariñas City, Cavite, Philippines
 Telefax: (046) 416-4920
 Email: cavite@tup.edu.ph | Website: www.tup.edu.ph

Travel expenses are likely one of the reasons why 30 students (34%) expressed an interest in staying in the dormitory if the construction plan is approved. However, according to the survey, this is only second to the reasons listed in table 5. It can be seen here that the main reason is the convenience that staying in the dormitory can bring, such as less travel time to school, not arriving late to classes, and having more time to relax and do homework. Two students have shown a desire to grow more independent while staying at the dormitory.

Table 5
 Reasons to stay in the dormitory

Reason	Frequency	Percentage
Convenience	13	48%
Daily expenses	12	44%
Independence	2	7%

Given a population proportion of 34% and a current student population of over 2000, it is estimated that 600 students would like to stay in the dormitory at this time. Despite the fact that such a large number will pose a challenge in terms of accommodation, this will most likely demonstrate that the project of constructing a dormitory on campus is appropriate.

Table 6 shows the number of students who want to improve their living conditions if they stay in a dormitory, such as having comfort, a quiet and peaceful environment, a stable internet connection, a study desk and chairs, and other items to help them sleep better.

Table 6
 Additional features of dormitory to enhance students living conditions

Feature	Frequency	Percentage
Study desk and chairs, and other items	7	37%
Stable internet connection	6	32%
Comfortable and peaceful environment	6	32%

The current design of the dormitory can address the first item in table 6 because there is a study area on the ground and second floors. The study area can accommodate 47 students in total.

Based on CHED memorandum Order No. 22 series of 2013, the features of decent and habitable dormitories are as follows:

1. comfortable bedrooms,
2. acceptable kitchen, laundry, receiving, dining, toilet, storage/cabinet, and
3. adequate supply of water and electricity

The current design of the dormitory demonstrates that, in accordance with the aforementioned CHED memorandum order, all of the students' needs are congruent with the features of the dormitory shown in the floor plan. For this sole reason, the government must support this project by allocating funds in 2024.



REPUBLIC OF THE PHILIPPINES
TECHNOLOGICAL UNIVERSITY OF THE PHILIPPINES
CAVITE CAMPUS

Carlos Q. Trinidad Avenue, Salawag, Dasmariñas City, Cavite, Philippines

Telefax: (046) 416-4920

Email: cavite@tup.edu.ph | Website: www.tup.edu.ph



References:

- CHED memorandum Order No. 22 series of 2013
- TUPC Bulletin of Information
- LUDIP of Technological University of the Philippines
- Residential Satisfaction in Student Housing An empirical study in Stockholm, Sweden
- Student Residential Satisfaction in an On-Campus Housing Facility
- Survey on Physical and Facilities Development of TUPC



TUPC DORMITORY DETAILED ENGINEERING DESIGN:

- ARCHITECTURAL PLAN
 - STRUCTURAL PLAN
 - ELECTRICAL PLAN
 - PLUMBING PLAN



TUPC DORMITORY DETAILED ARCHITECTURAL PLAN



P E R S P E C T I V E

CONSTRUCTION OF PROPOSED TUPC DORMITORY

LEGEND

- A. GUARD HOUSE
- B. POWER HOUSE
- C. MARKER/ROUND ABOUT W/ LANDSCAPING
- D. CAMPUS FLAG POLE
- E. ADMINISTRATION BUILDING
- F. PROPOSED PARKING AREA
- G. MALE AND FEMALE TOILET
- H. ELEVATED WATER TANK
- I. PROPOSED CISTERN
- J. COVERED COURT
- K. STUDENT CENTER BLDG.
- L. ROTC PARADE GROUND
- M. ACADEMIC BLDG. AND OPEN-AIR AUDITORIUM
- N. PROPOSED NEW CHAPEL W/ LANDSCAPES
- O. PHYSICS & CHEMISTRY BLDG.
- P. ENGINEERING BLDG.
- Q. ECO PARK AND MICROFARMING
- R. FOOD COURT
- S. RESEARCH AND EXTENSION
- T. CATERING BLDG.
- U. IT FACULTY BLDG.
- V. AET BLDG.
- W. ESTERET BLDG.
- X. PROPOSED CONVERSION OF EET BLDG. TO 2-STORY 4-CLASSROOM BLDG.
- Y. PROPOSED CONVERSION OF ESET BUILDING TO 2-STORY 4-CLASSROOM BLDG.
- Z. IT BUILDING
- AA. ART SHOP
- BB. PROPOSED RENOVATION OF COMPUTER BUILDING
- CC. SMART TOWER
- DD. DRAWING AREA
- EE. HANG AREA
- FF. HOME ECONOMICS BUILDING
- GG. TAN CHING BUILDING
- HH. PROPOSED RENOVATION COMMON C.R.
- II. EXISTING COVERED PATHWALK
- JJ. PROPOSED LANDSCAPING
- KK. PROPOSED COVERED PATHWALK
- LL. ROAD EXTENSION
- MM. PROPOSED STP
- NN. INFORMATION TECHNOLOGY CENTER
- OO. PROPOSED EMPLOYEES BARACKS
- PP. PROPOSED DORMITORY
- QQ. M.R.F.
- RR. STUDY SHED
- SS. LEARNING RESOURCE CENTER
- TT. ACADEMIC BUILDING
- EA. ENGINEERING AND ARCHITECTURE BLDG.

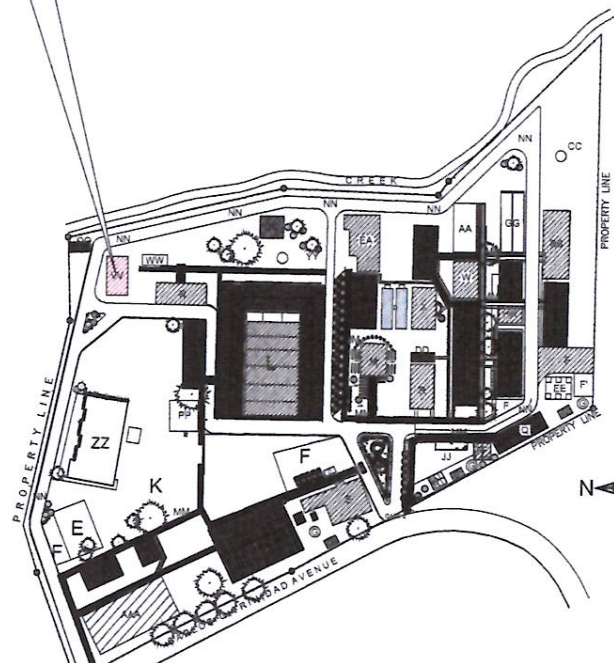

2 SITE DEVELOPMENT PLAN/KEY PLAN
A-1 SCALE 1:1000

THE SITE

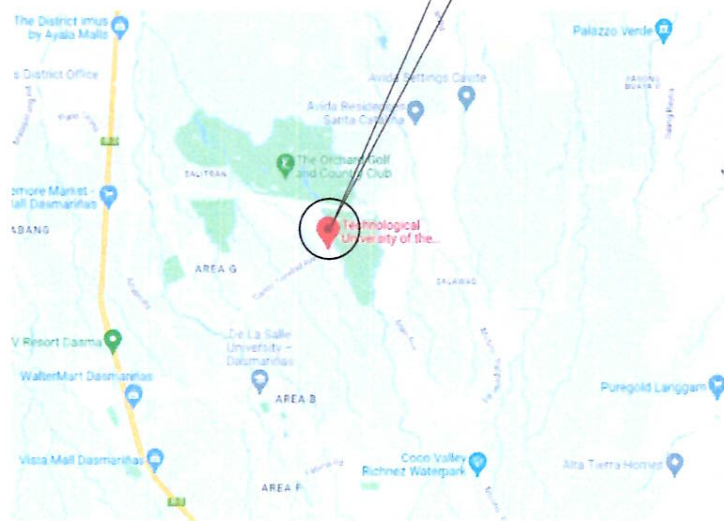

3 VICINITY MAP
A-1 SCALE NTS

TABLE OF CONTENTS

ARCHITECTURAL

- 1 PERSPECTIVE VIEW, VICINITY MAP, SITE DEVELOPMENT PLAN & TABLE OF CONTENTS
- 2 GROUND FLOOR PLAN
- 3 SECOND FLOOR PLAN
- 4 THIRD FLOOR PLAN
- 5 FOURTH FLOOR PLAN
- 6 BASEMENT FLOOR PLAN
- 7 ROOF PLAN
- 8 FRONT ELEVATION
- 9 FRONT-SIDE ELEVATION
- 10 LEFT-SIDE ELEVATION
- 11 REAR ELEVATION
- 12 CROSS SECTIONAL LONGITUDINAL SECTION
- 13 SCHEDULE OF DOORS AND WINDOWS
- 14 DETAIL OF KITCHEN
- 15 CABINET DETAIL PLAN
- 16 TOILET DETAIL
- 17 TOILET DETAIL
- 18 GROUND FLOOR STAIR DETAIL
- 19 TOILET DETAIL
- 20 STAIR DETAIL PLAN
- 21 STAIR SECTION DETAIL
- 22 SPOT DETAIL (INCLUDED)
- 23 STAIR SPOT DETAILS
- 24 REFLECTIVE CEILING PLAN - GROUND FLOOR PLAN
- 25 REFLECTIVE CEILING PLAN - SECOND FLOOR PLAN
- 26 REFLECTIVE CEILING PLAN - THIRD FLOOR PLAN
- 27 REFLECTIVE CEILING PLAN - FOURTH FLOOR PLAN
- 28 REFLECTIVE CEILING PLAN - BASEMENT FLOOR PLAN
- 29 CEILING DETAIL (ISOMETRIC)
- 30 CEILING SECTION DETAIL

REPUBLIC OF THE PHILIPPINES
TUPC
TECHNOLOGICAL UNIVERSITY OF THE PHILIPPINES - CAVITE CAMPUS

DISTRICT / CITY / MUNICIPALITY

LAND USE AND ZONING

LINE AND GRADE

ARCHITECTURAL

STRUCTURAL

SANITARY

ELECTRICAL

ELECTRONICS

MECHANICAL

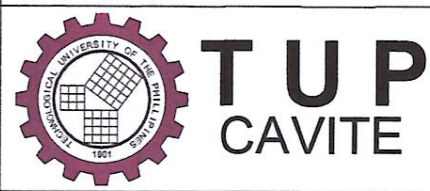

PROJECT TITLE:
PROPOSED TUPC DORMITORY

DESIGNED BY:
ENGR. BRYLLE EPHRAIEM Q. NAVARRO
IDO, CHAIRPERSON

APPROVED BY:
ENGR. ALEXANDER E. MAG-ISA, Ph.D., PME
CAMPUS DIRECTOR

DESIGNED BY:
IDO - CAVITE
CAD BY:

SHEET NO.
A 1

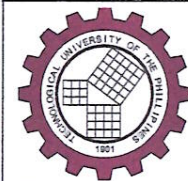
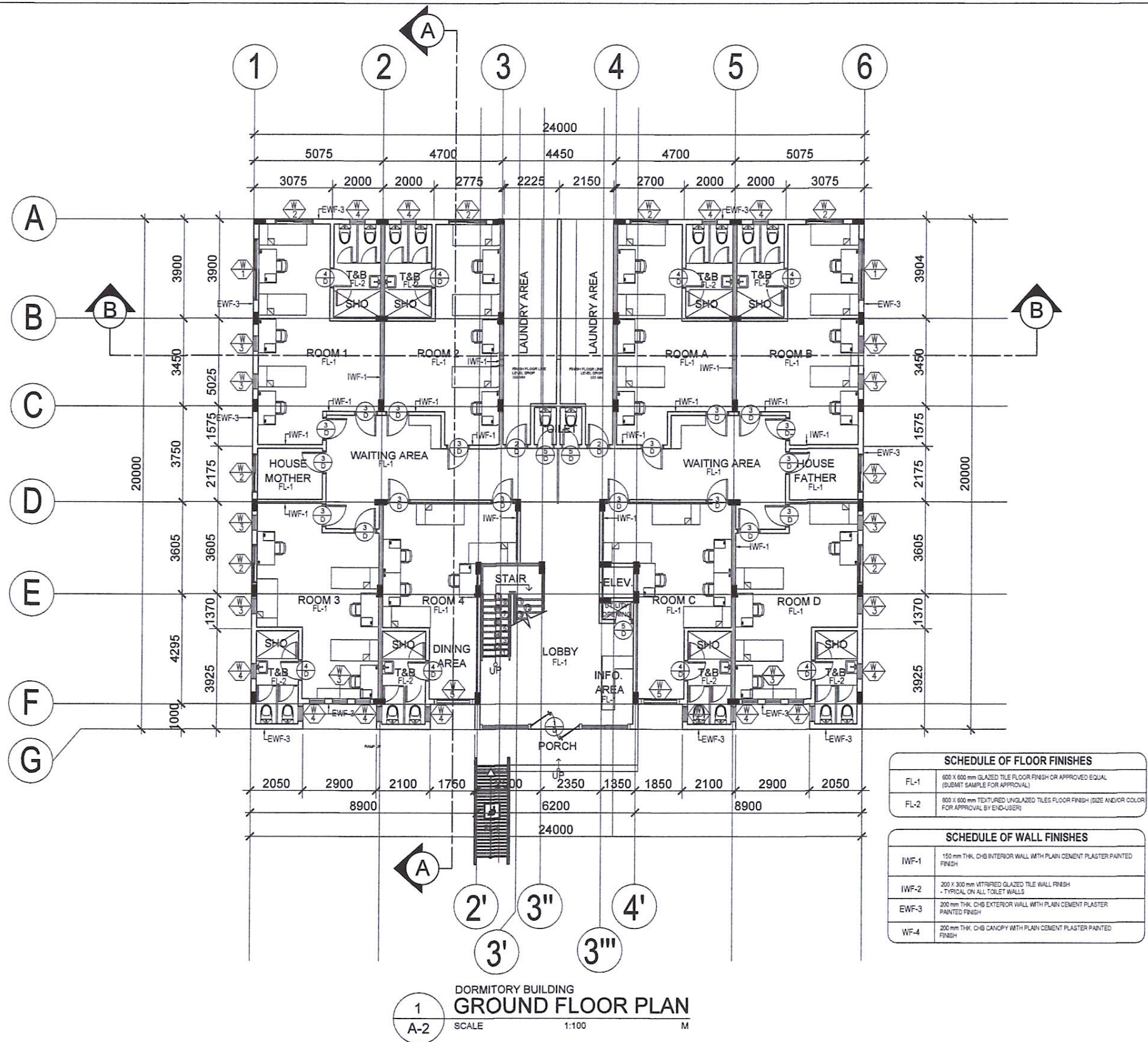

**TUP
CAVITE**

PROJECT TITLE:
**PROPOSED TUPC
DORMITORY**

DESIGNED BY:
ENGR. BRYLLE EPHRAIEM Q. NAVARRO
IDO, CHAIRPERSON

APPROVED BY:
ENGR. ALEXANDER E. MAG-ISA, Ph.D., PME
CAMPUS DIRECTOR

DESIGNED BY:
IDO - CAVITE
CAD BY:

SHEET NO.
A 2

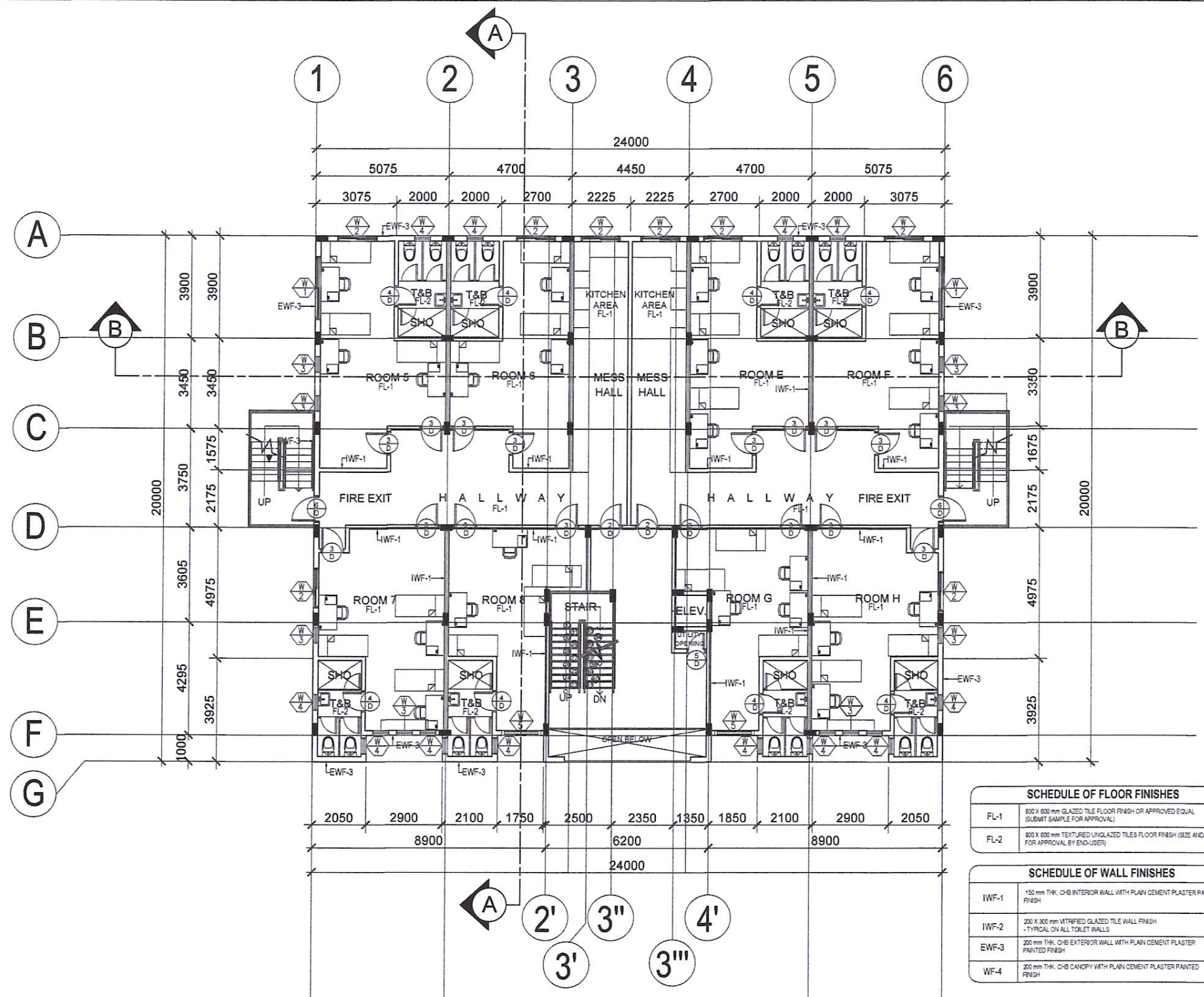

SCHEDULE OF FLOOR FINISHES	
FL-1	600 X 600 mm GLAZED TILE FLOOR FINISH OR APPROVED EQUAL (SUBMIT SAMPLE FOR APPROVAL)
FL-2	600 X 600 mm TEXTURED UNGLAZED TILES FLOOR FINISH (SIZE AND/OR COLOR FOR APPROVAL BY END-USER)

SCHEDULE OF WALL FINISHES	
IWF-1	150 mm THK. C&B INTERIOR WALL WITH PLAIN CEMENT PLASTER PAINTED FINISH
IWF-2	200 X 300 mm METRIC GLAZED TILE WALL FINISH - TYPICAL ON ALL TOILET WALLS
EW-3	200 mm THK. C&B EXTERIOR WALL WITH PLAIN CEMENT PLASTER PAINTED FINISH
WF-4	200 mm THK. C&B CANOPY WITH PLAIN CEMENT PLASTER PAINTED FINISH

1 DORMITORY BUILDING
 A-3 SECOND FLOOR PLAN
 SCALE 1:100 M

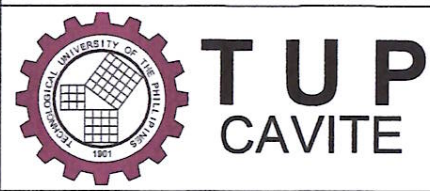

TUP CAVITE	PROJECT TITLE:	DESIGNED BY:	APPROVED BY:	DESIGNED BY:	SHEET NO.
	PROPOSED TUPC DORMITORY	ENGR. BRYLLE EPHRAIEM Q. NAVARRO IDO, CHAIRPERSON	 ENGR. ALEXANDER E. MAG-ISA, Ph.D., PME CAMPUS DIRECTOR	IDO - CAVITE CAD BY:	

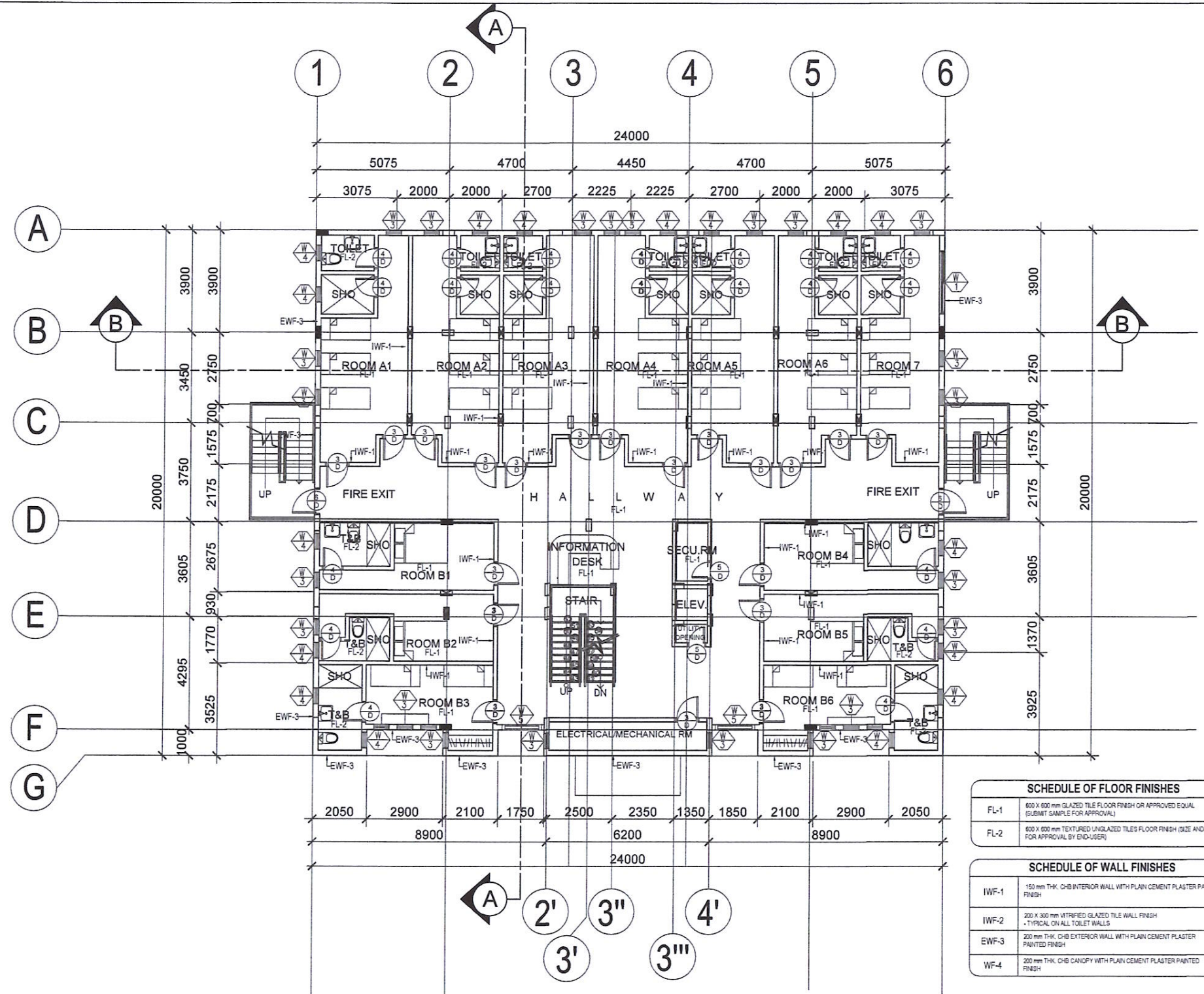

1
A-4
DORMITORY BUILDING
THIRD FLOOR PLAN
SCALE 1:100 M

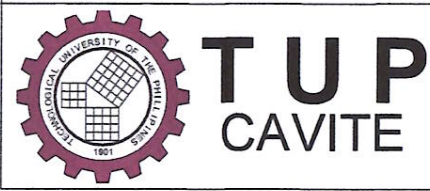

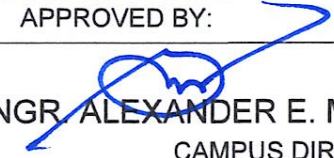
TUP CAVITE	PROJECT TITLE:	DESIGNED BY:	APPROVED BY:	DESIGNED BY:	SHEET NO.
	PROPOSED TUPC DORMITORY	ENGR. BRYLLE EPHRAEM Q. NAVARRO IDO, CHAIRPERSON	 ENGR. ALEXANDER E. MAG-ISA, Ph.D., PME CAMPUS DIRECTOR	IDO - CAVITE CAD BY:	A 4

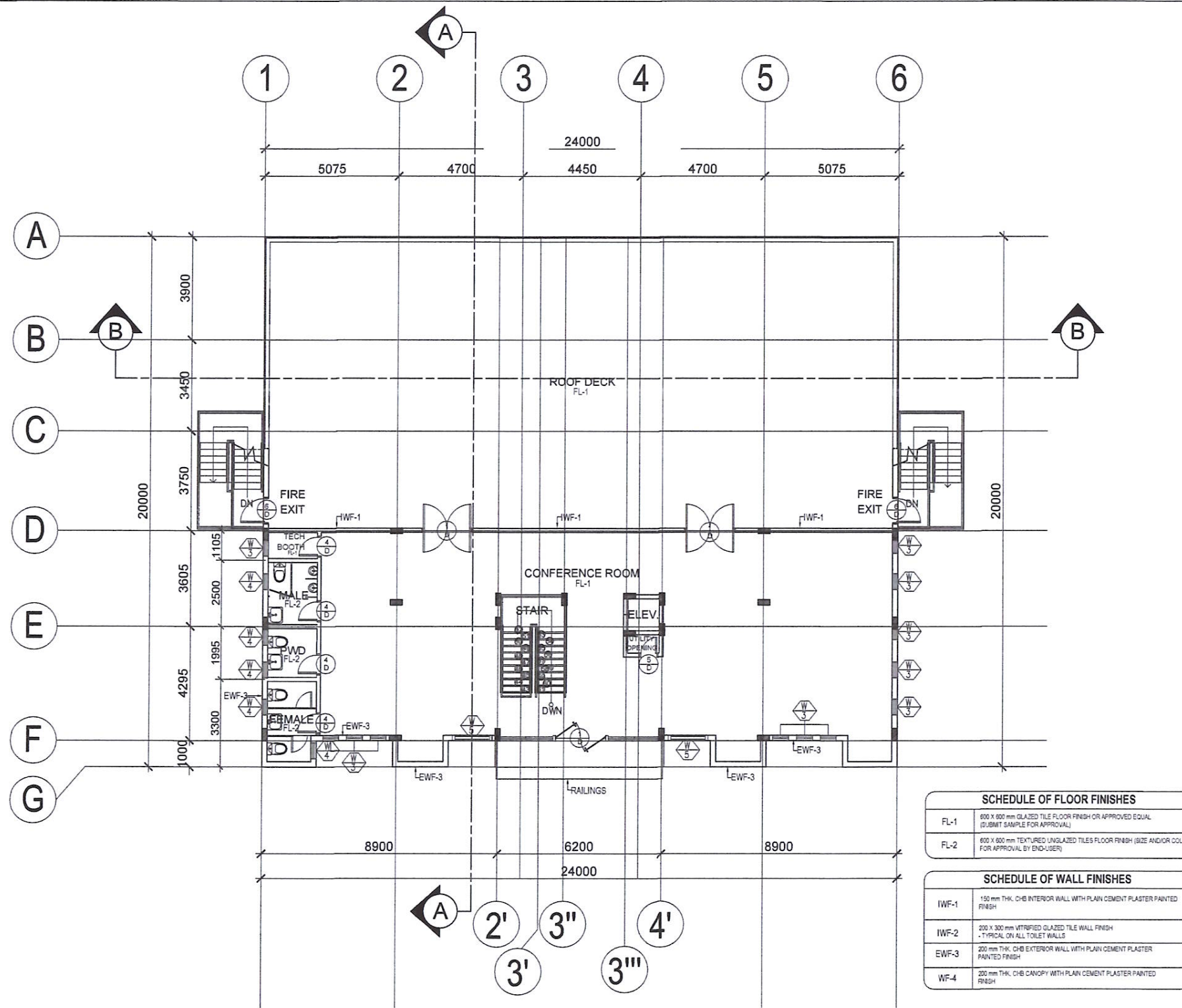

1
A-5
DORMITORY BUILDING
FOURTH FLOOR PLAN
SCALE 1:100 M

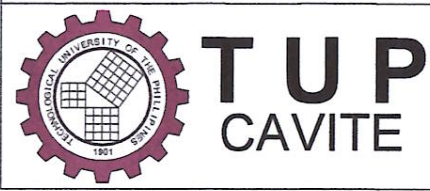

PROJECT TITLE:
PROPOSED TUPC DORMITORY

DESIGNED BY:
ENGR. BRYLLE EPHRAIEM Q. NAVARRO
IDO, CHAIRPERSON

APPROVED BY:
ENGR. ALEXANDER E. MAG-ISA, Ph.D., PME
CAMPUS DIRECTOR

DESIGNED BY:
IDO - CAVITE
CAD BY:

SHEET NO.
A 5

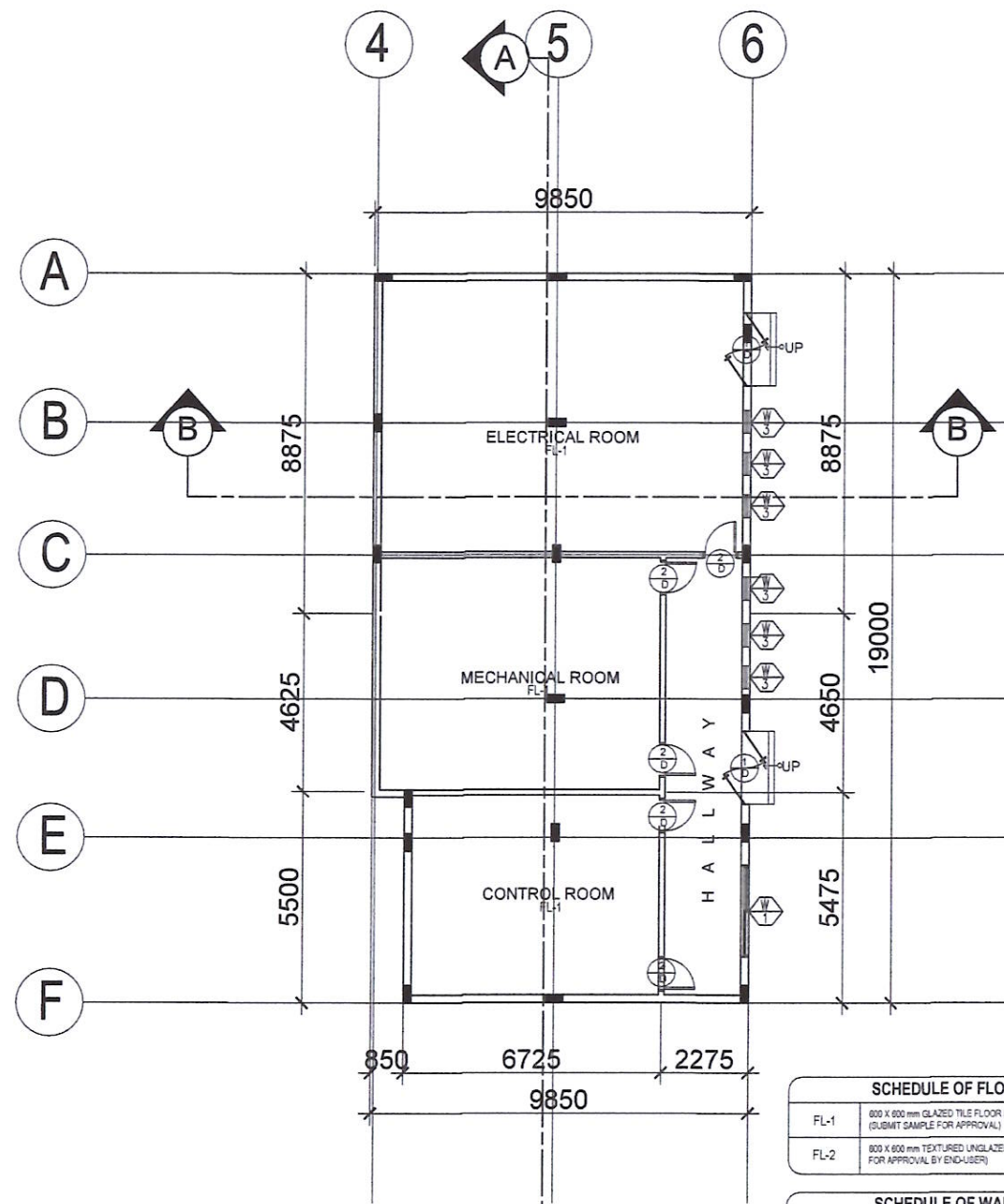

1
A-6
DORMITORY BUILDING
BASEMENT FLOOR PLAN
SCALE 1:100 M

SCHEDULE OF FLOOR FINISHES	
FL-1	800 X 800 mm GLAZED TILE FLOOR FINISH OR APPROVED EQUAL (SUBMIT SAMPLE FOR APPROVAL)
FL-2	800 X 800 mm TEXTURED UNGLAZED TILES FLOOR FINISH (SIZE AND/OR COLOR FOR APPROVAL BY END-USER)

SCHEDULE OF WALL FINISHES	
IWF-1	150 mm THK. C-8 INTERIOR WALL WITH PLAIN CEMENT PLASTER PAINTED FINISH
IWF-2	200 X 300 mm VITRIFIED GLAZED TILE WALL FINISH - TYPICAL ON ALL TOILET WALLS
EW-3	200 mm THK. C-8 EXTERIOR WALL WITH PLAIN CEMENT PLASTER PAINTED FINISH
WF-4	200 mm THK. C-8 CANOPY WITH PLAIN CEMENT PLASTER PAINTED FINISH

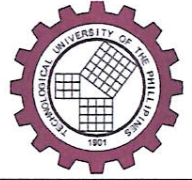

TUP
CAVITE

PROJECT TITLE:
PROPOSED TUPC DORMITORY

DESIGNED BY:
[Signature]
ENGR. BRYLLE EPHRAIEM Q. NAVARRO
IDO, CHAIRPERSON

APPROVED BY:
[Signature]
ENGR. ALEXANDER E. MAG-ISA, Ph.D., PME
CAMPUS DIRECTOR

DESIGNED BY:
IDO - CAVITE
CAD BY:

SHEET NO.
A 6

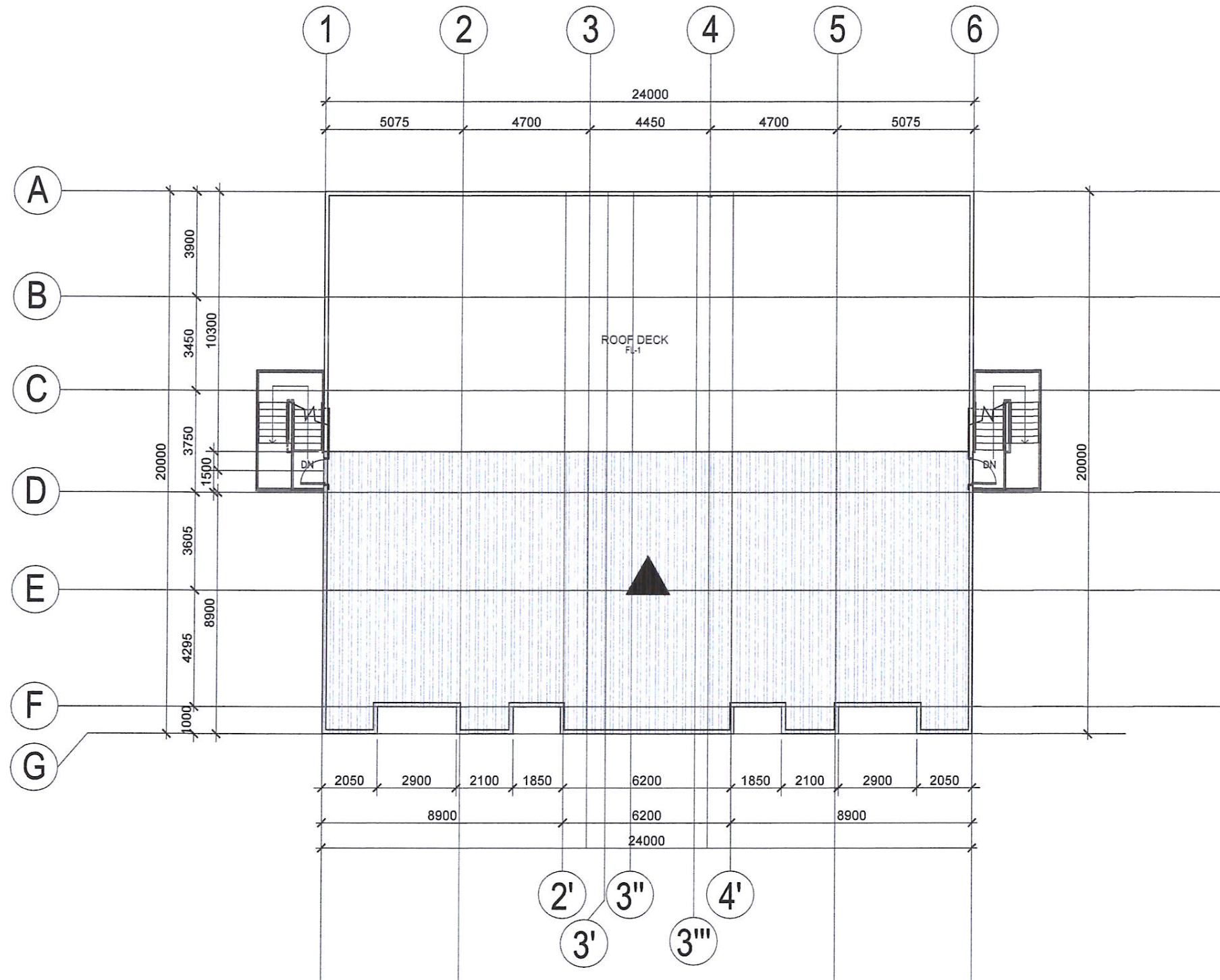

1 ROOF PLAN
A-7 SCALE 1:100 M

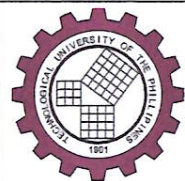

TUP
CAVITE

PROJECT TITLE:
PROPOSED TUPC DORMITORY

DESIGNED BY:
ENGR. BRYLLE EPARRAIEM Q. NAVARRO
IDO, CHAIRPERSON

APPROVED BY:
ENGR. ALEXANDER E. MAG-ISA, Ph.D., PME
CAMPUS DIRECTOR

DESIGNED BY:
IDO - CAVITE
CAD BY:

SHEET NO.
A 7

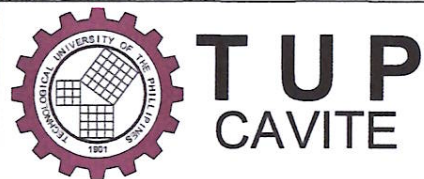
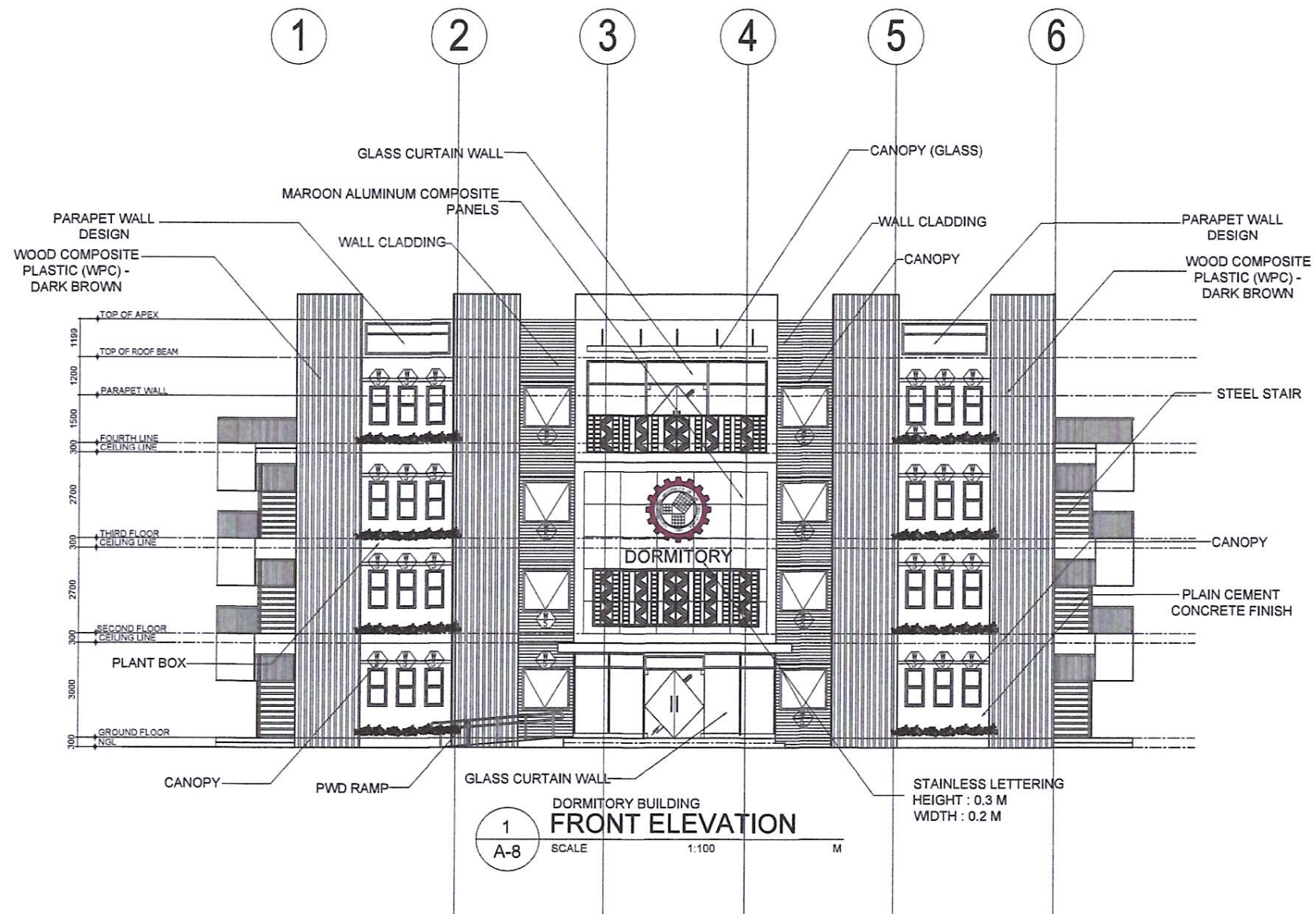

PROJECT TITLE:
**PROPOSED TUPC
DORMITORY**

DESIGNED BY:
[Signature]
ENGR. BRYLLE EPHRAIEM Q. NAVARRO
IDO, CHAIRPERSON

APPROVED BY:
[Signature]
ENGR. ALEXANDER E. MAG-ISA, Ph.D., PME
CAMPUS DIRECTOR

DESIGNED BY:
IDO - CAVITE
CAD BY:

SHEET NO.
A 8

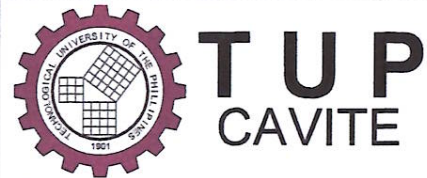
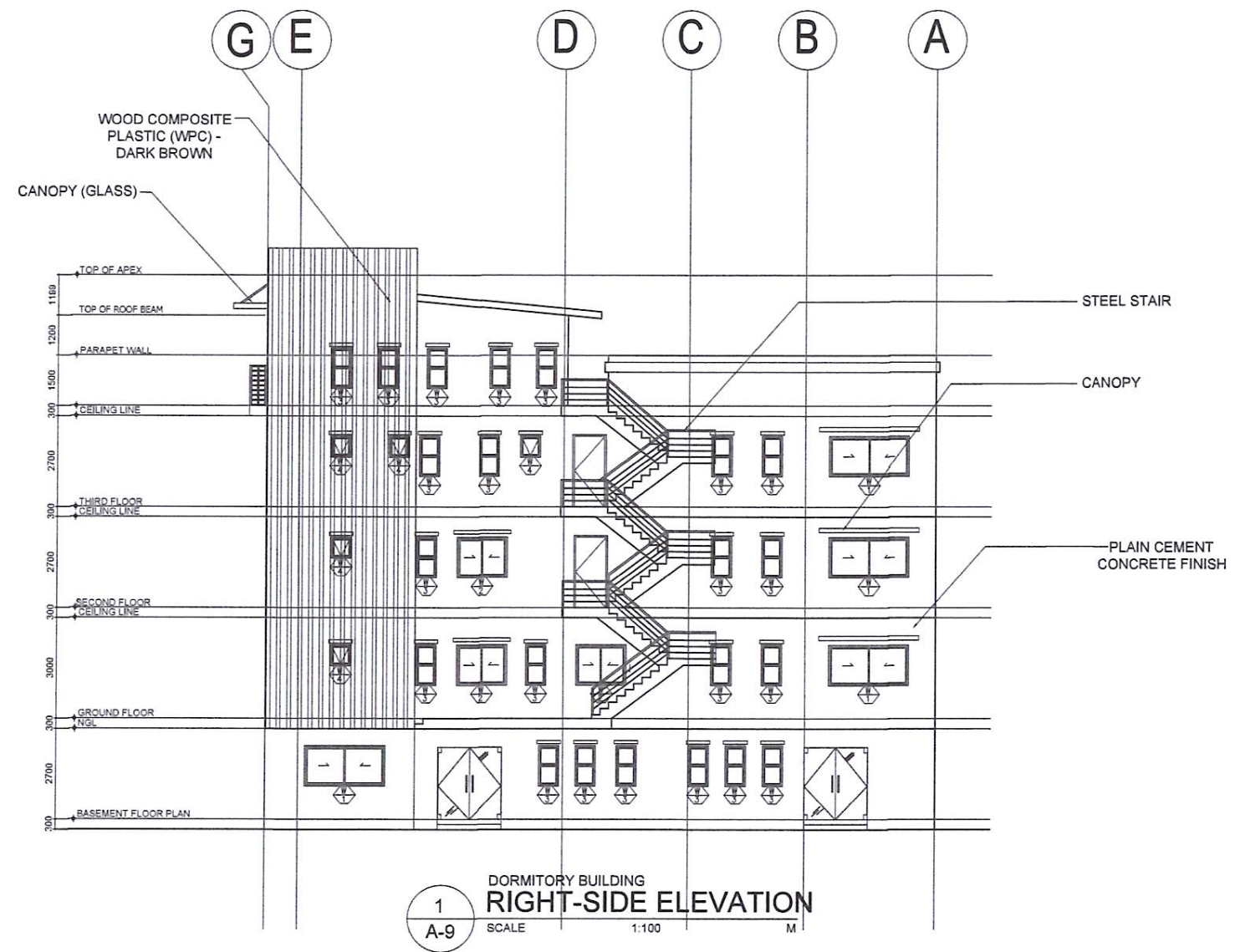

PROJECT TITLE:
**PROPOSED TUPC
 DORMITORY**

DESIGNED BY:
 ENGR. BRYLLE EPHEAEM Q. NAVARRO
 IDO, CHAIRPERSON

APPROVED BY:
 ENGR. ALEXANDER E. MAG-ISA, Ph.D., PME
 CAMPUS DIRECTOR

DESIGNED BY:
 IDO - CAVITE
 CAD BY:

SHEET NO.
A 9

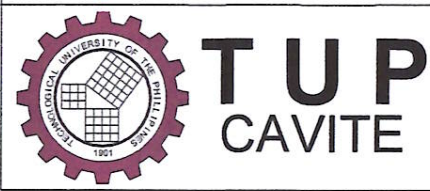
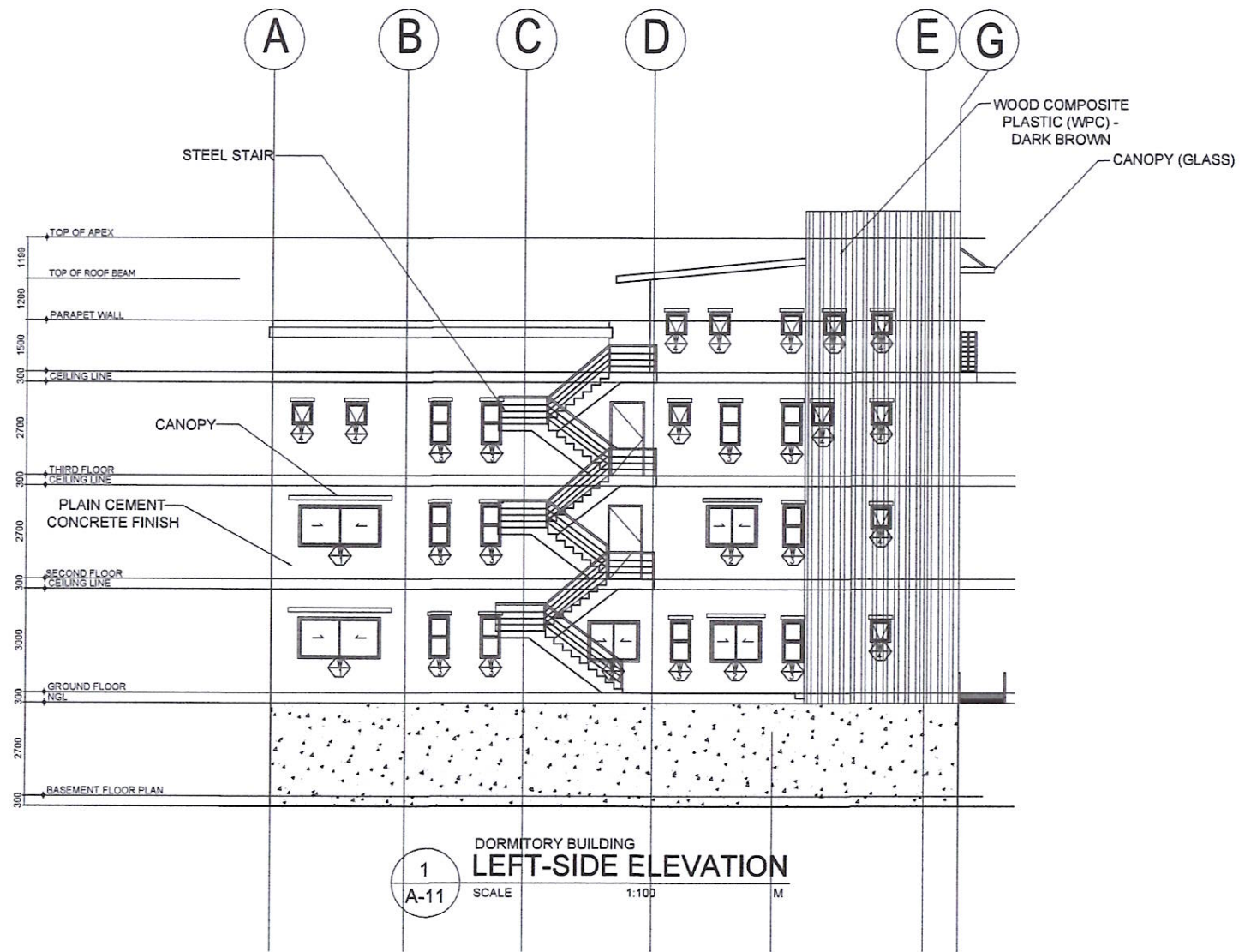

PROJECT TITLE:
PROPOSED TUPC DORMITORY

DESIGNED BY:
 ENGR. BRYLLE EPHRAIEM Q. NAVARRO
 IDO, CHAIRPERSON

APPROVED BY:
 ENGR. ALEXANDER E. MAG-ISA, Ph.D., PME
 CAMPUS DIRECTOR

DESIGNED BY:
 IDO - CAVITE
 CAD BY:

SHEET NO.
A 10

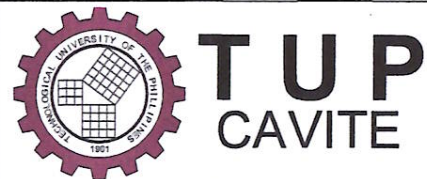
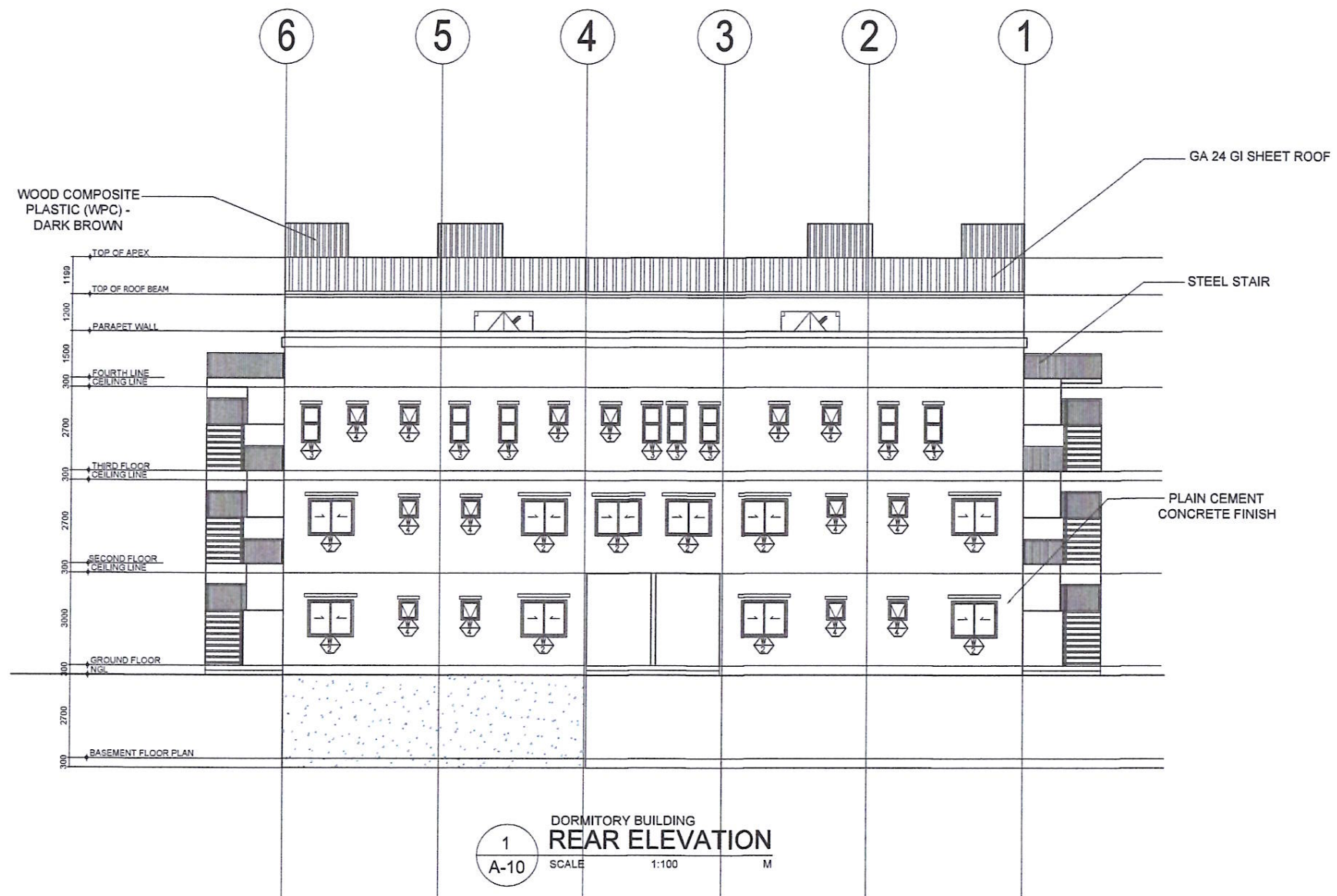

PROJECT TITLE:
**PROPOSED TUPC
DORMITORY**

DESIGNED BY:
[Signature]
ENGR. BRYLLE EPHRAIEM Q. NAVARRO
IDO, CHAIRPERSON

APPROVED BY:
[Signature]
ENGR. ALEXANDER E. MAG-ISA, Ph.D., PME
CAMPUS DIRECTOR

DESIGNED BY:
IDO - CAVITE
CAD BY:

SHEET NO.
A 11

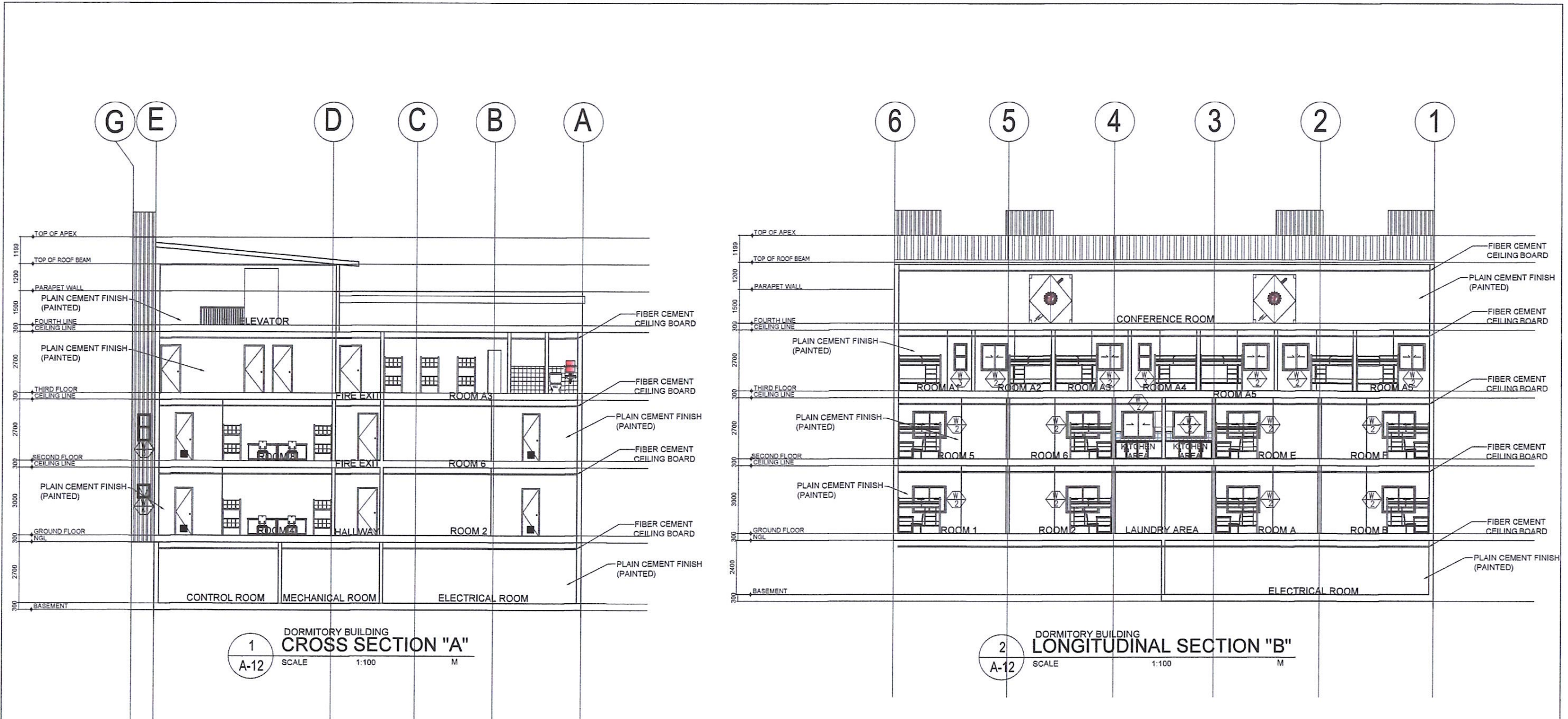

1 DORMITORY BUILDING
CROSS SECTION "A"
 A-12 SCALE 1:100 M

2 DORMITORY BUILDING
LONGITUDINAL SECTION "B"
 A-12 SCALE 1:100 M

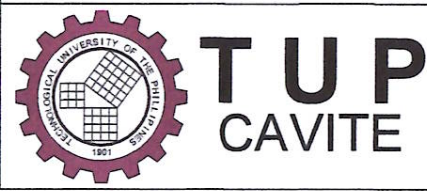

PROJECT TITLE:
PROPOSED TUPC DORMITORY

DESIGNED BY:
 ENGR. BRYLLE EPHRAIEM Q. NAVARRO
 IDO, CHAIRPERSON

APPROVED BY:
 ENGR. ALEXANDER E. MAG-ISA, Ph.D., PME
 CAMPUS DIRECTOR

DESIGNED BY:
 IDO - CAVITE
 CAD BY:

SHEET NO.
A 12

1 SCHEDULE OF DOORS AND WINDOWS
A-13 SCALE 1:100 M

W1	W2	W3	W4	W5	
SLIDING WINDOW	SLIDING WINDOW	AWNING WINDOW	AWNING WINDOW	FIXED WINDOW	
6 SETS	16 SETS	70 SETS	45 SETS	8 SETS	
LOCATION: BEDROOMS, BASEMENT	LOCATION: BEDROOMS, HOUSE MOTHER & FATHER, KITCHEN	LOCATION: BEDROOMS AND FRONT	LOCATION: TOILET AND BATH	LOCATION: FRONT	
D1	D2	D3	D4	D5	D6
GLASS DOOR OR APPROVED EQUAL SWING TYPE	GLASS DOOR OR APPROVED EQUAL SWING TYPE	SOLID FLUSH DOOR	PVC FLUSH DOOR WITH LOUVER	HOLLOW CORE FLUSH DOOR	STEEL DOOR
4 SET	4 SETS	55 SETS	40 SETS	7 SETS	6 SETS
LOCATION: PORCH, ROOF	LOCATION: LOBBY AND HALLWAY	LOCATION: BEDROOMS	LOCATION: TOILET AND BATH	LOCATION: TOILET AND BATH	LOCATION: FIRE EXITS

BP 344 CONSIDERATION

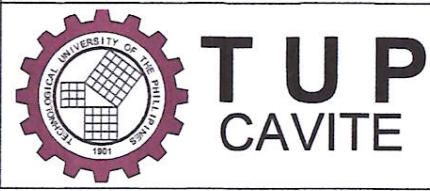
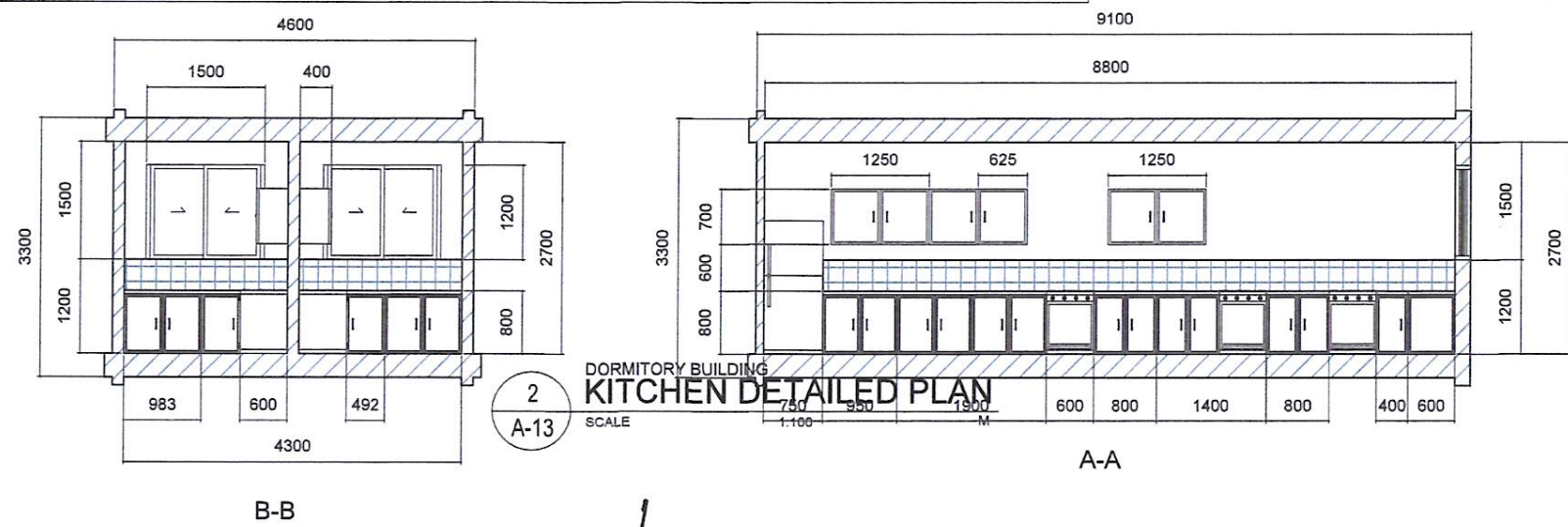
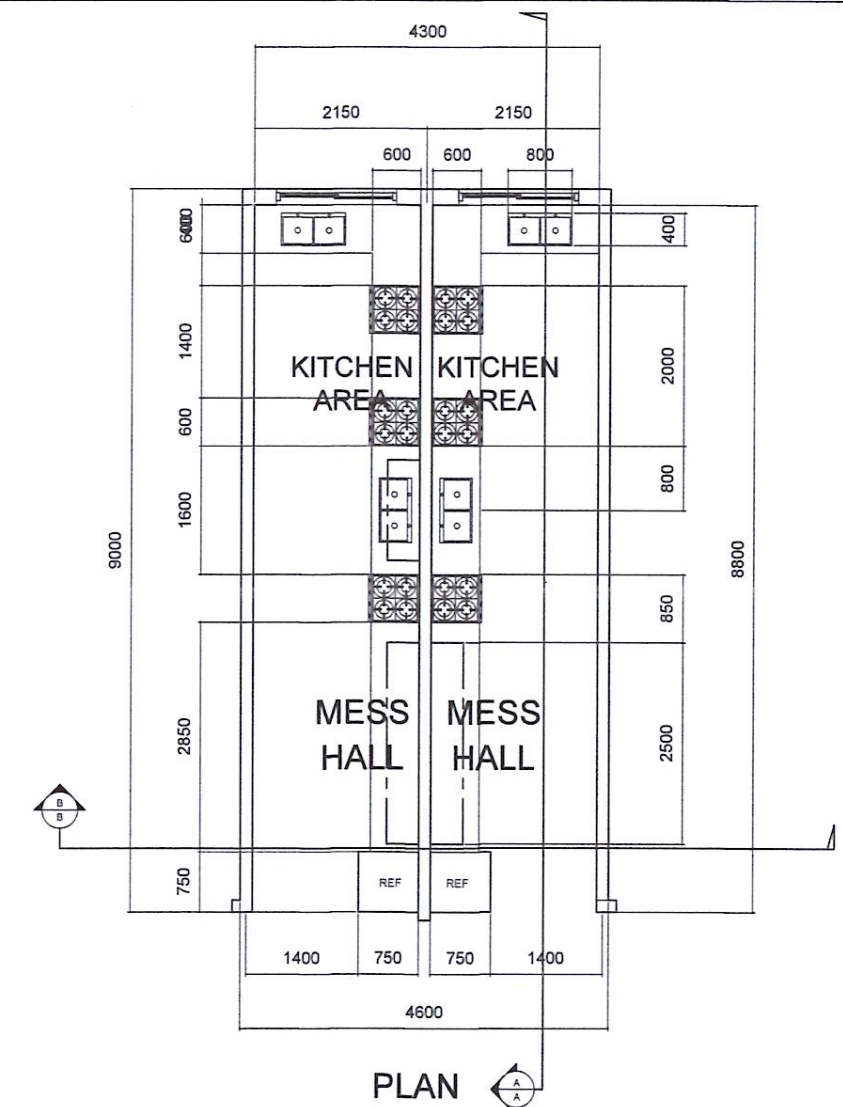
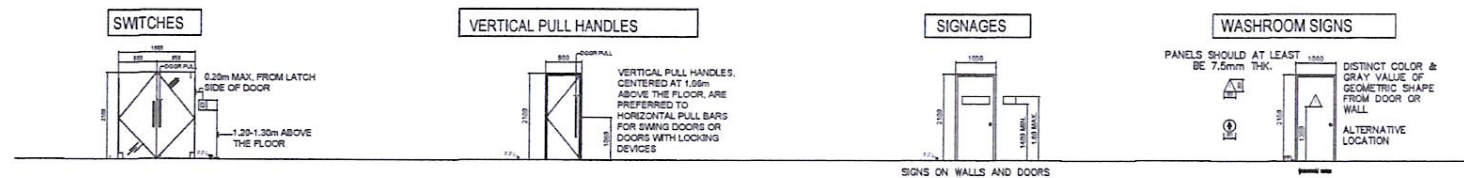

PROJECT TITLE:
PROPOSED TUPC DORMITORY

DESIGNED BY:
ENGR. BRYLLE EPHRAIEM Q. NAVARRO
IDO, CHAIRPERSON

APPROVED BY:
ENGR. ALEXANDER E. MAG-ISA, Ph.D., PME
CAMPUS DIRECTOR

DESIGNED BY:
IDO - CAVITE
CAD BY:

SHEET NO.
A 13

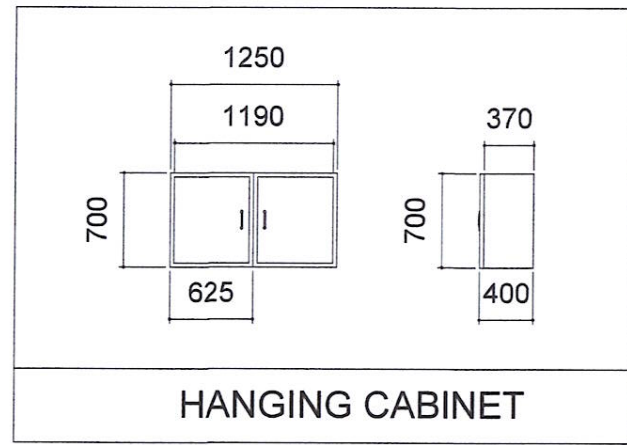

HANGING CABINET

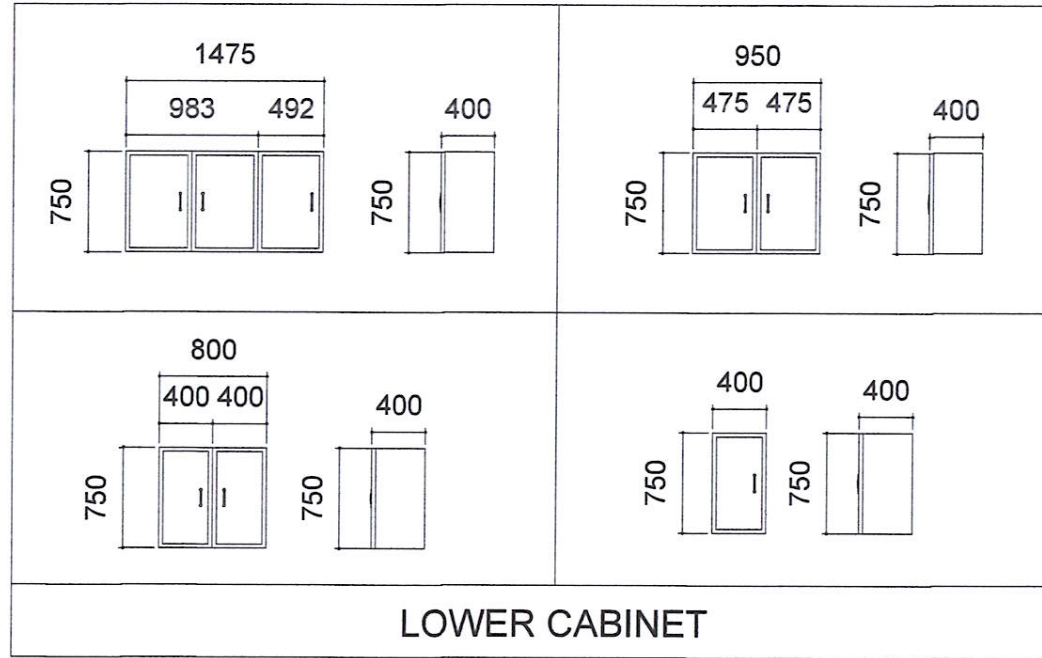

LOWER CABINET

1 DORMITORY BUILDING
CABINET DETAILED PLAN
A-14 SCALE 1:100 M

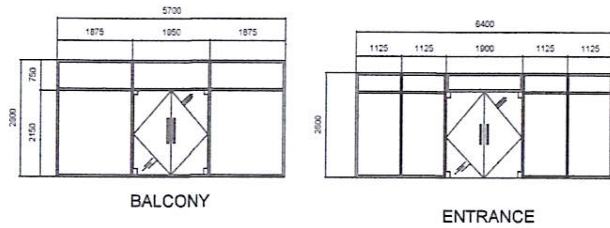

BALCONY

ENTRANCE

1 DORMITORY BUILDING
CURTAIN GLASS DETAILED PLAN
A-14 SCALE 1:100 M

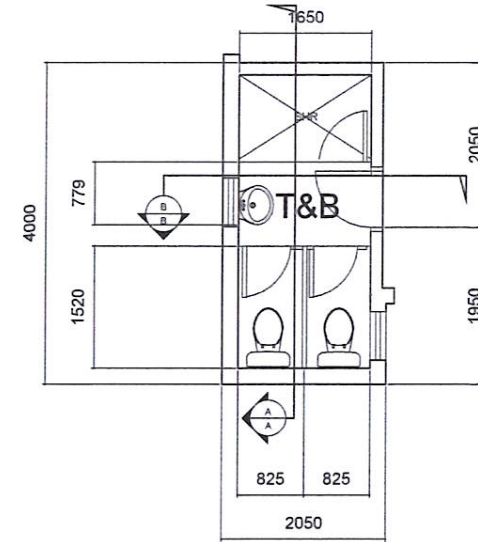

PLAN

4000

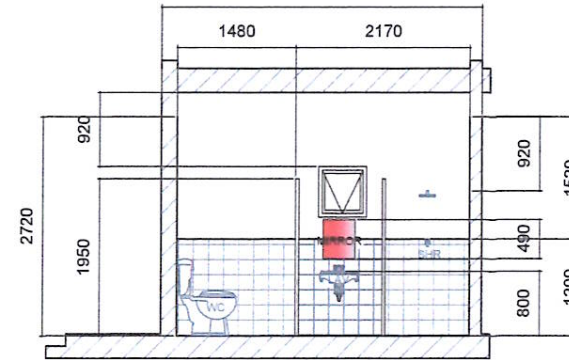

A-A

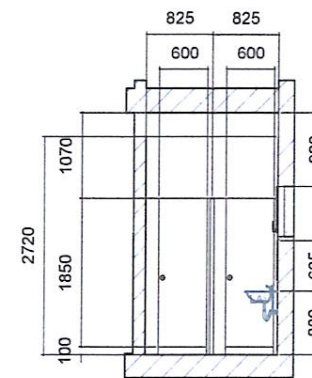

B-B

(GROUND FLOOR)
TOILET RM3 DETAIL
SCALE: 1:100 METERS

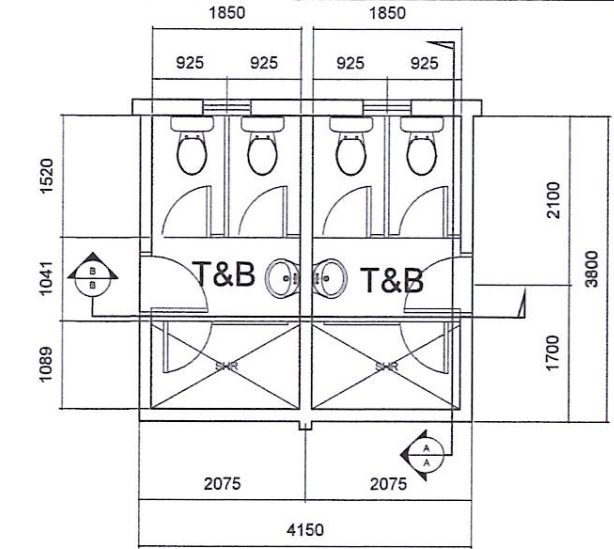

PLAN

4000

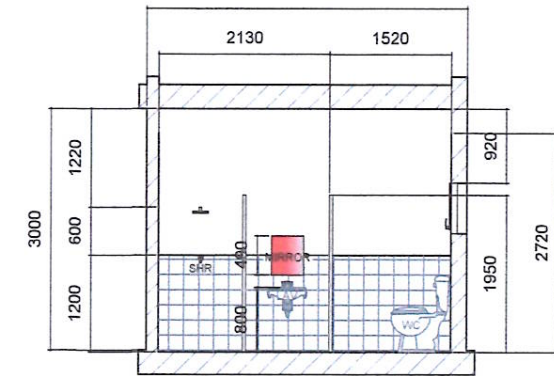

A-A

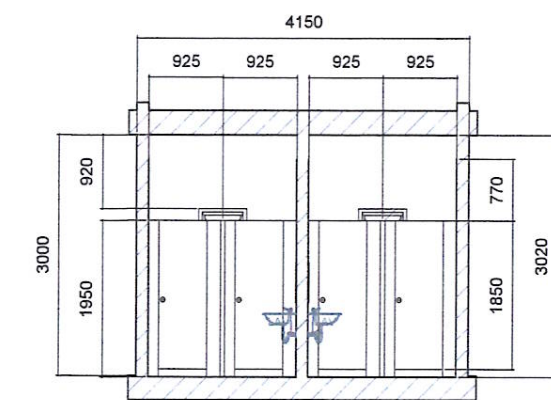

B-B

(GROUND FLOOR)
TOILET RM1&2 DETAIL
SCALE: 1:100 METERS

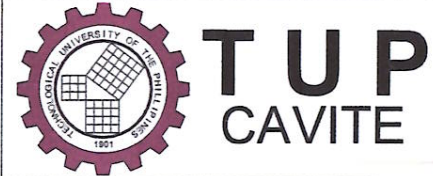

PROJECT TITLE:
PROPOSED TUPC DORMITORY

DESIGNED BY:
ENGR. BRYLLE EPHRAIEM Q. NAVARRO
IDO, CHAIRPERSON

APPROVED BY:
ENGR. ALEXANDER E. MAG-ISA, Ph.D., PME
CAMPUS DIRECTOR

DESIGNED BY:
IDO - CAVITE
CAD BY:

SHEET NO.
A 14

CABINET DETAIL PLAN
TOILET DETAIL

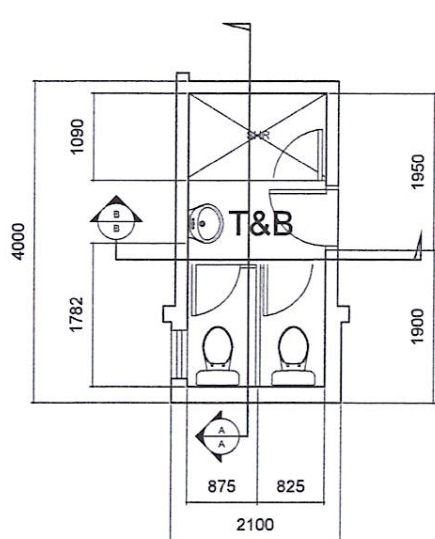

PLAN

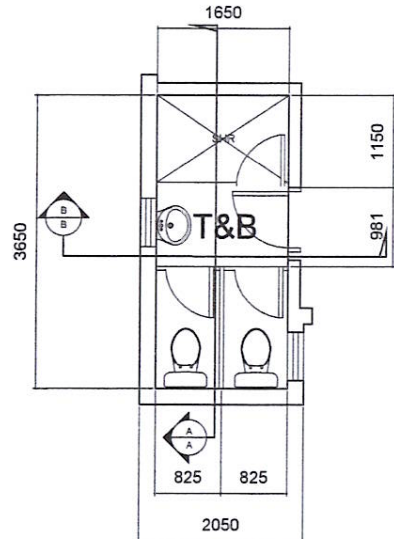

PLAN

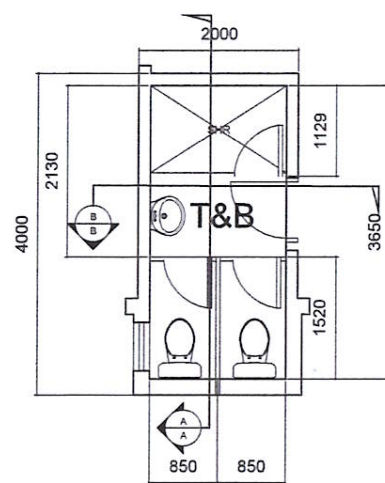

PLAN

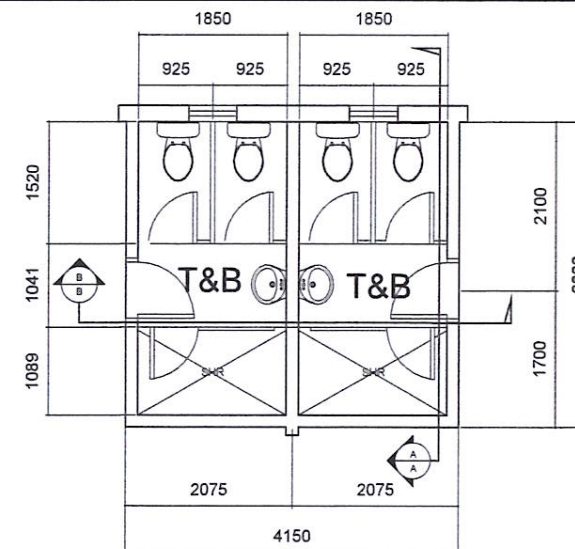

PLAN

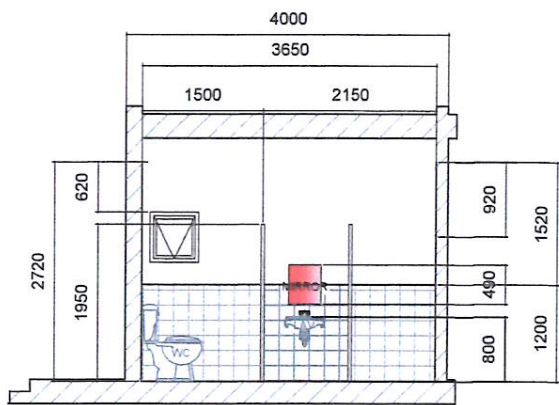

A-A

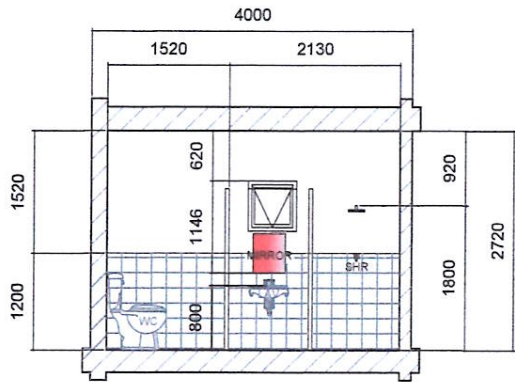

A-A

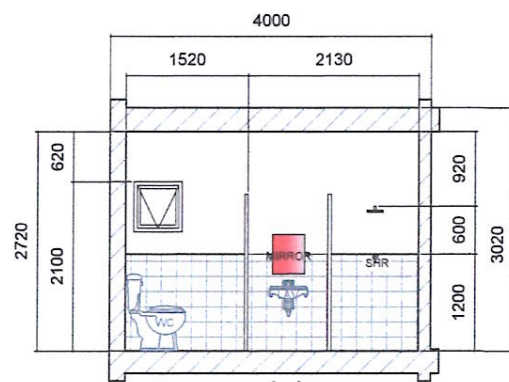

A-A

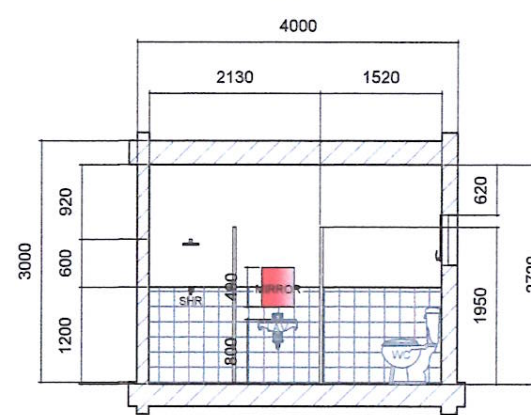

A-A

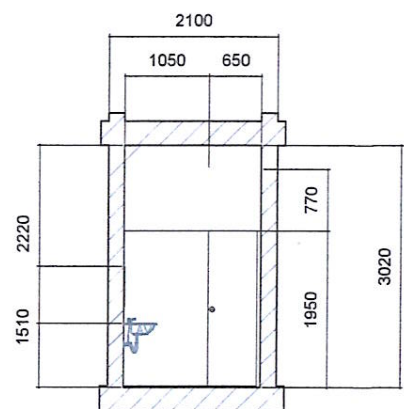

B-B

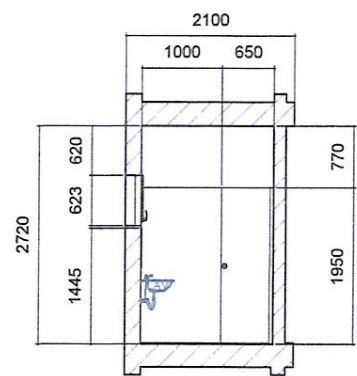

B-B

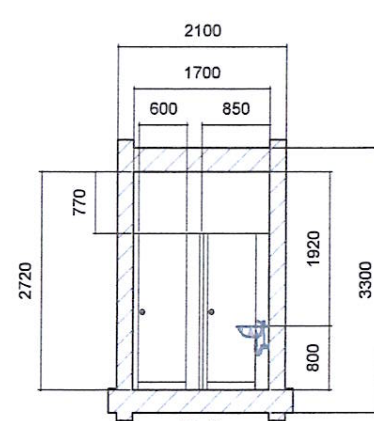

B-B

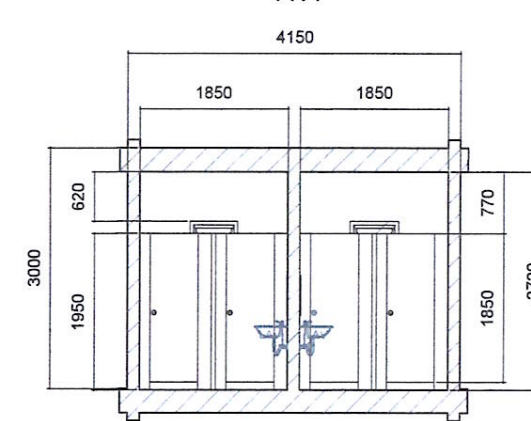

B-B

(GROUND FLOOR)
TOILET RM4 DETAIL
SCALE: 1:100 METERS

(SECOND FLOOR)
TOILET RM7 DETAIL
SCALE: 1:100 METERS

(SECOND FLOOR)
TOILET RM8 DETAIL
SCALE: 1:100 METERS

(SECOND FLOOR)
TOILET RM5&6 DETAIL
SCALE: 1:100 METERS
TOILET DETAIL

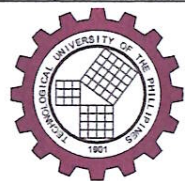

TUP
CAVITE

PROJECT TITLE:
**PROPOSED TUPC
DORMITORY**

DESIGNED BY:
ENGR. BRYLLE EPHRAIEM Q. NAVARRO
IDO, CHAIRPERSON

APPROVED BY:
ENGR. ALEXANDER E. MAG-ISA, Ph.D., PME
CAMPUS DIRECTOR

DESIGNED BY:
IDO - CAVITE
CAD BY:

SHEET NO.
A 15

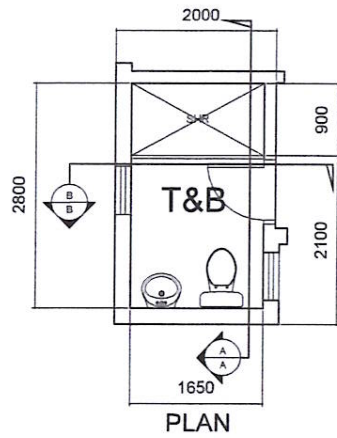

PLAN

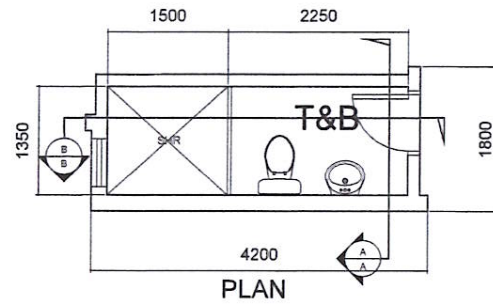

PLAN

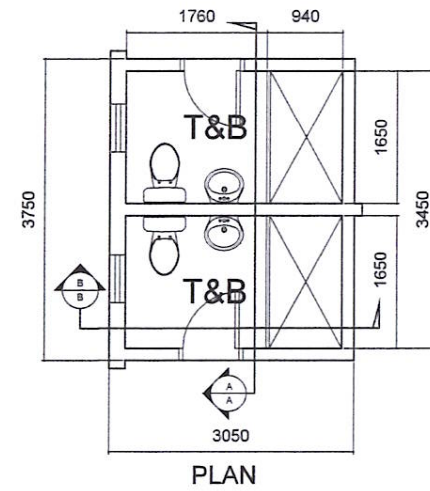

PLAN

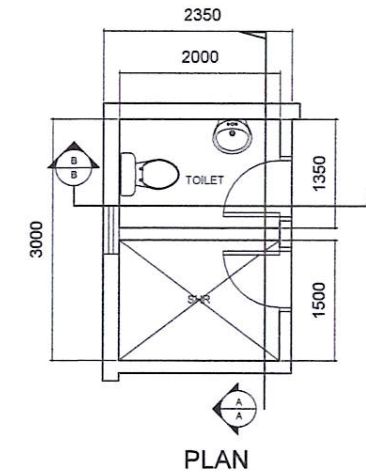

PLAN

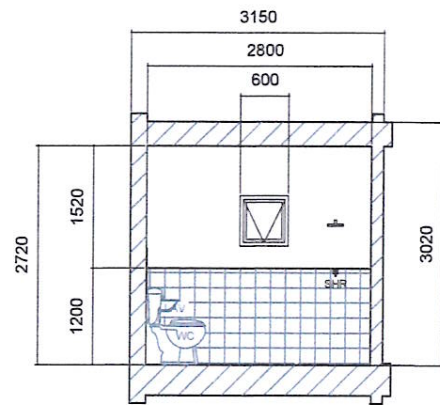

A-A

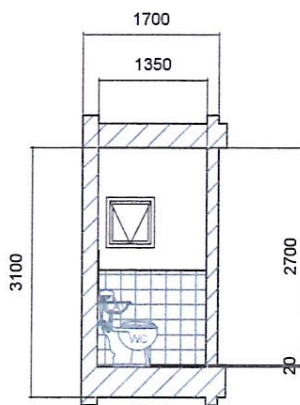

A-A

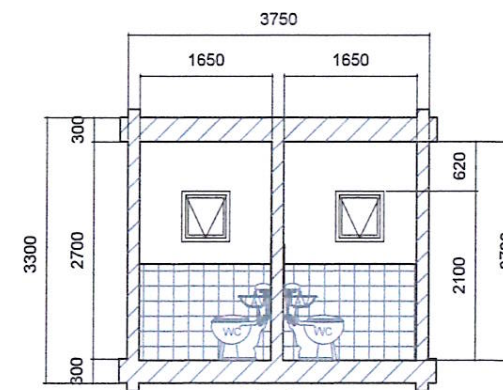

A-A

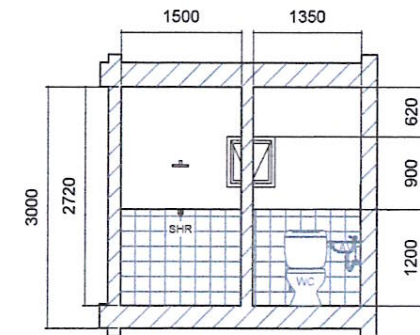

A-A

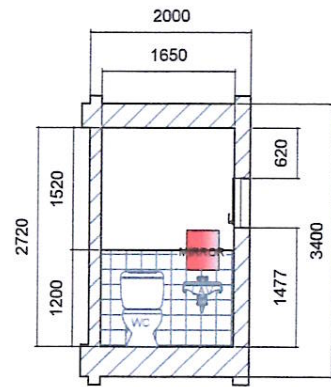

B-B

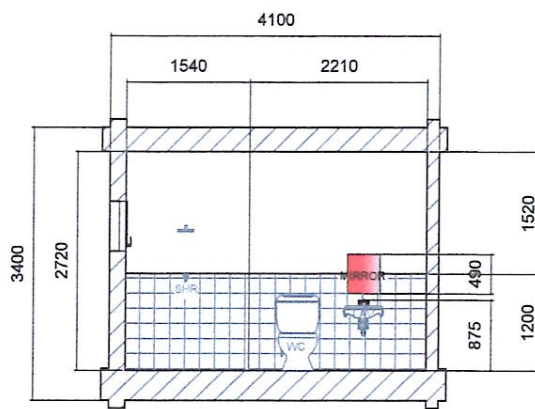

B-B

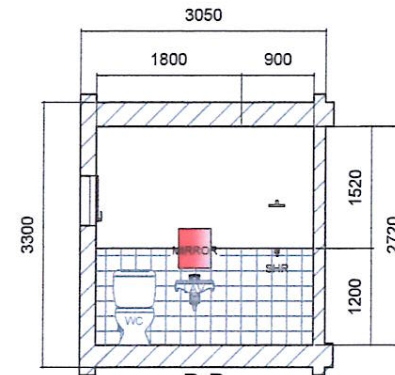

B-B

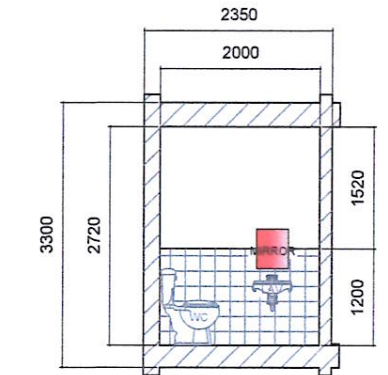

B-B

(THIRD FLOOR)
TOILET RMB3 DETAIL
SCALE: 1:100 METERS

(THIRD FLOOR)
TOILET RMB7 DETAIL
SCALE: 1:100 METERS

(THIRD FLOOR)
TOILET RMB1&B2 DETAIL
SCALE: 1:100 METERS

(THIRD FLOOR)
TOILET RMA1 DETAIL
SCALE: 1:100 METERS

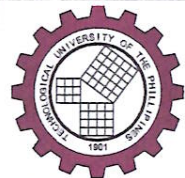

TUP
CAVITE

PROJECT TITLE:
**PROPOSED TUPC
DORMITORY**

DESIGNED BY:
ENGR. BRYLLE EPHRAIEM Q. NAVARRO
IDO, CHAIRPERSON

APPROVED BY:
ENGR. ALEXANDER E. MAG-ISA, Ph.D., PME
CAMPUS DIRECTOR

DESIGNED BY:
IDO - CAVITE
CAD BY:

SHEET NO.
A 16

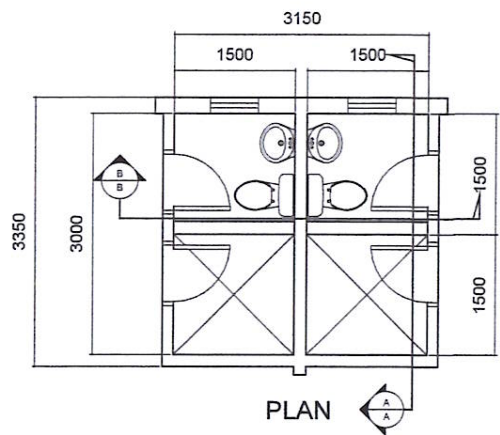

PLAN

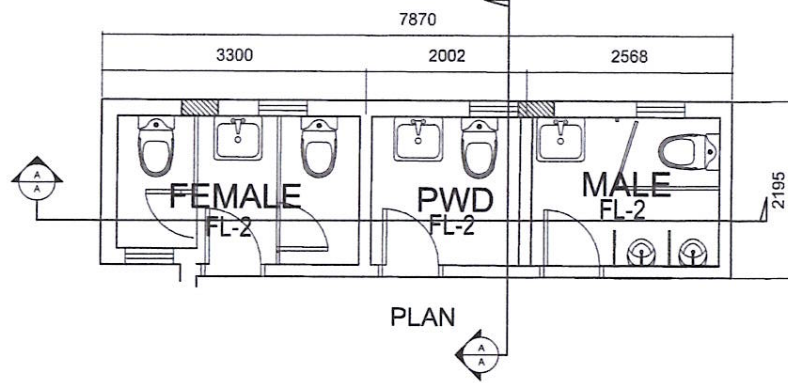

PLAN

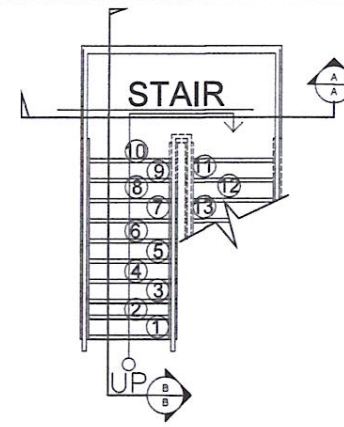

GROUND FLOOR PLAN

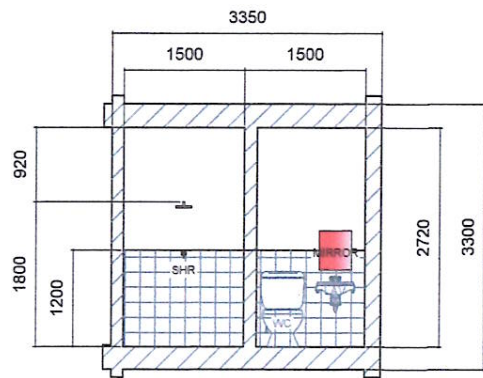

A-A

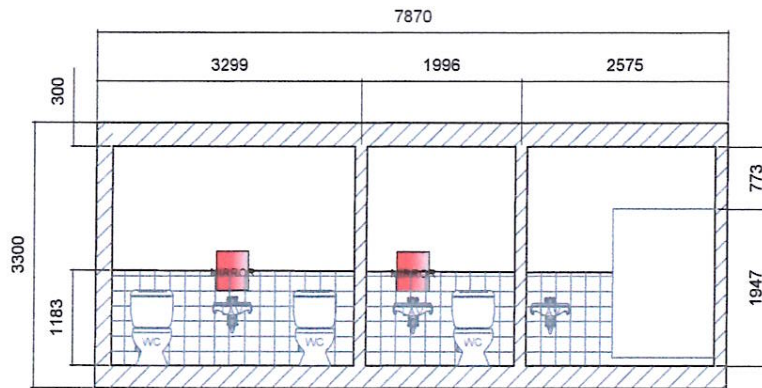

A-A

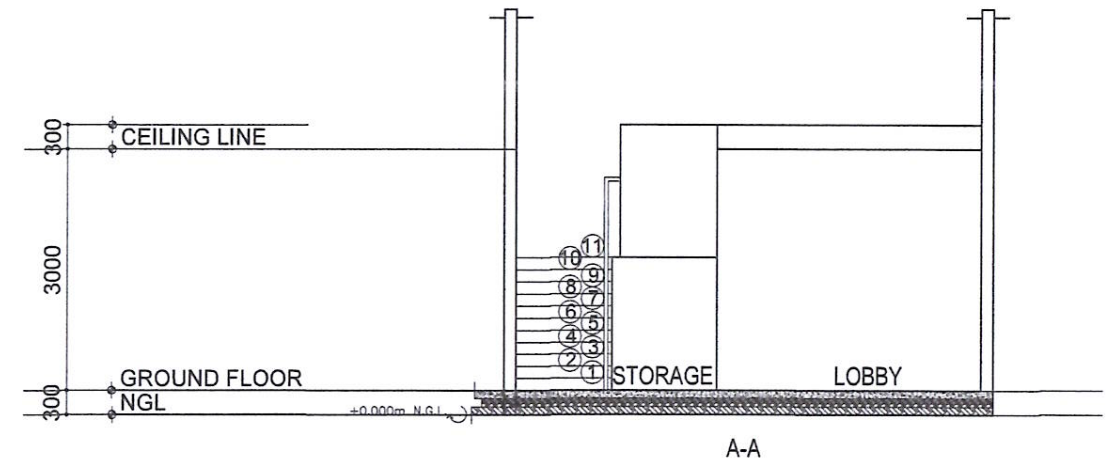

A-A

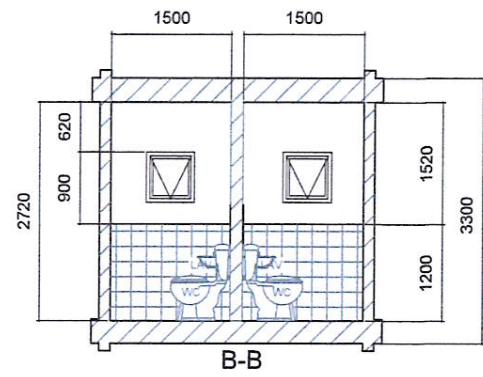

B-B

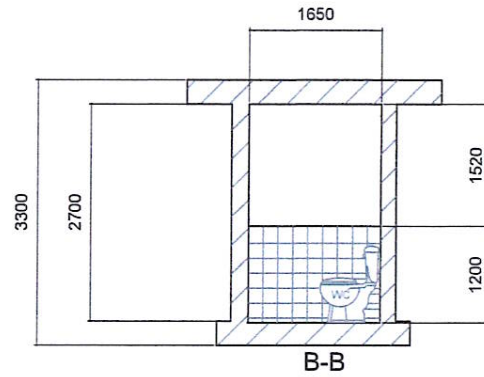

B-B

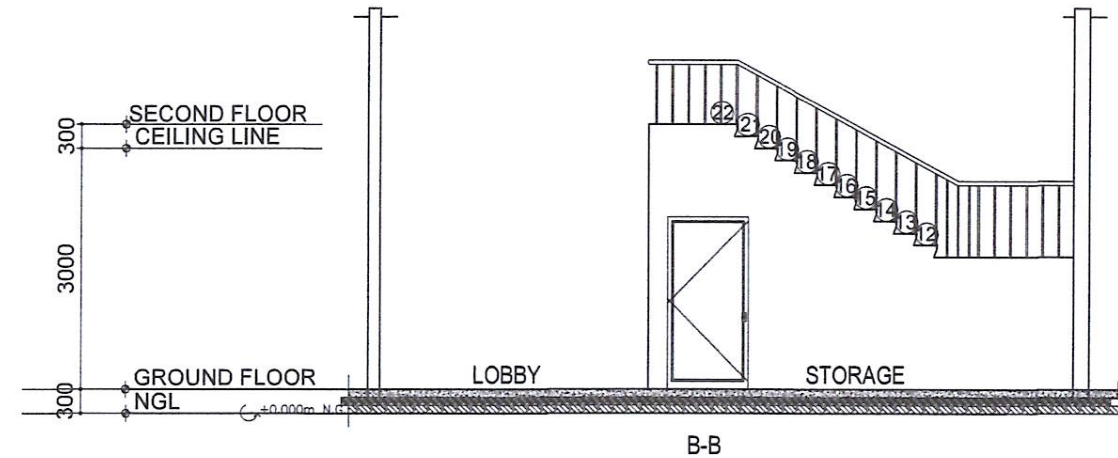

B-B

(THIRD FLOOR)
TOILET RMA2&A3 DETAIL
SCALE: 1:100 METERS

(FOURTH FLOOR)
TOILET DETAIL
SCALE: 1:100 METERS

2 GROUND FLOOR STAIR DETAIL PLAN
SCALE: 1:50 M

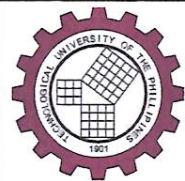

TUP
CAVITE

PROJECT TITLE:
PROPOSED TUPC DORMITORY

DESIGNED BY:
ENGR. BRYLLE EPHRAIEM Q. NAVARRO
IDO, CHAIRPERSON

APPROVED BY:
ENGR. ALEXANDER E. MAG-ISA, Ph.D., PME
CAMPUS DIRECTOR

DESIGNED BY:
IDO - CAVITE
CAD BY:

SHEET NO.
A 17

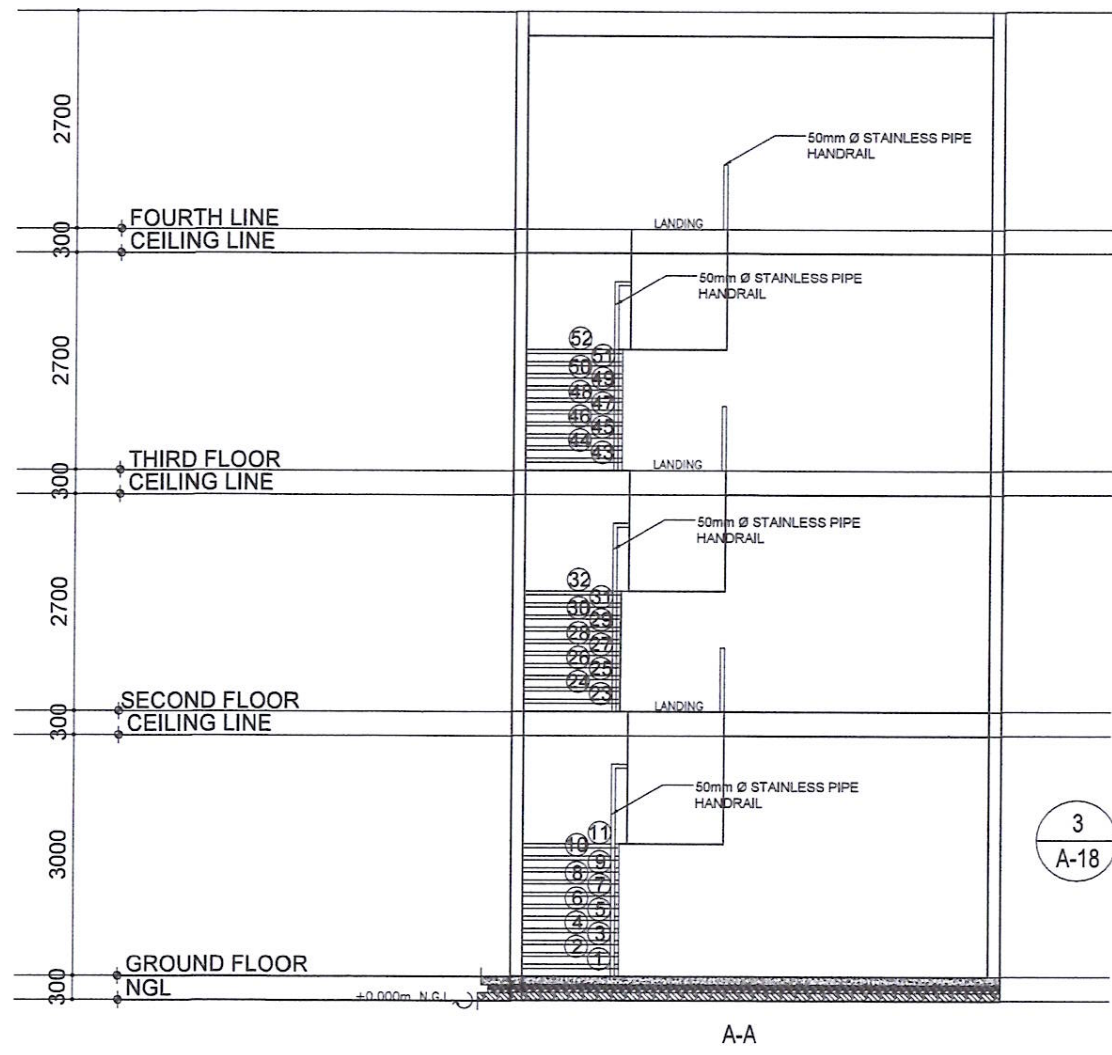
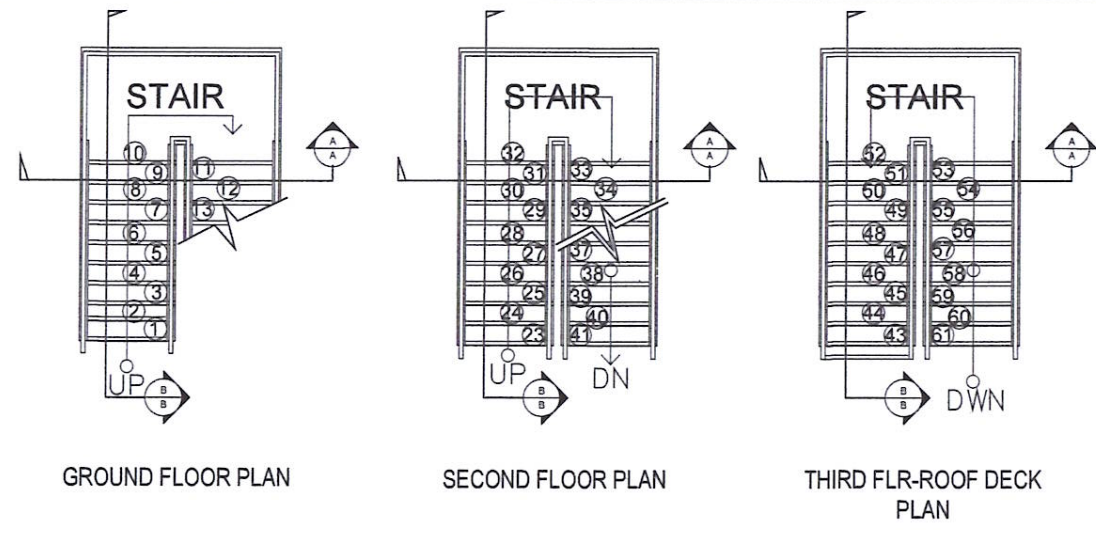

3 STAIR SECTION DETAIL
A-18 SCALE 1:50 M

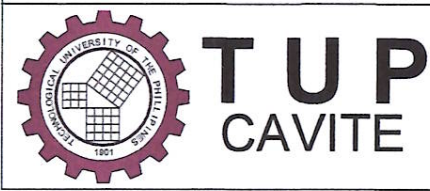
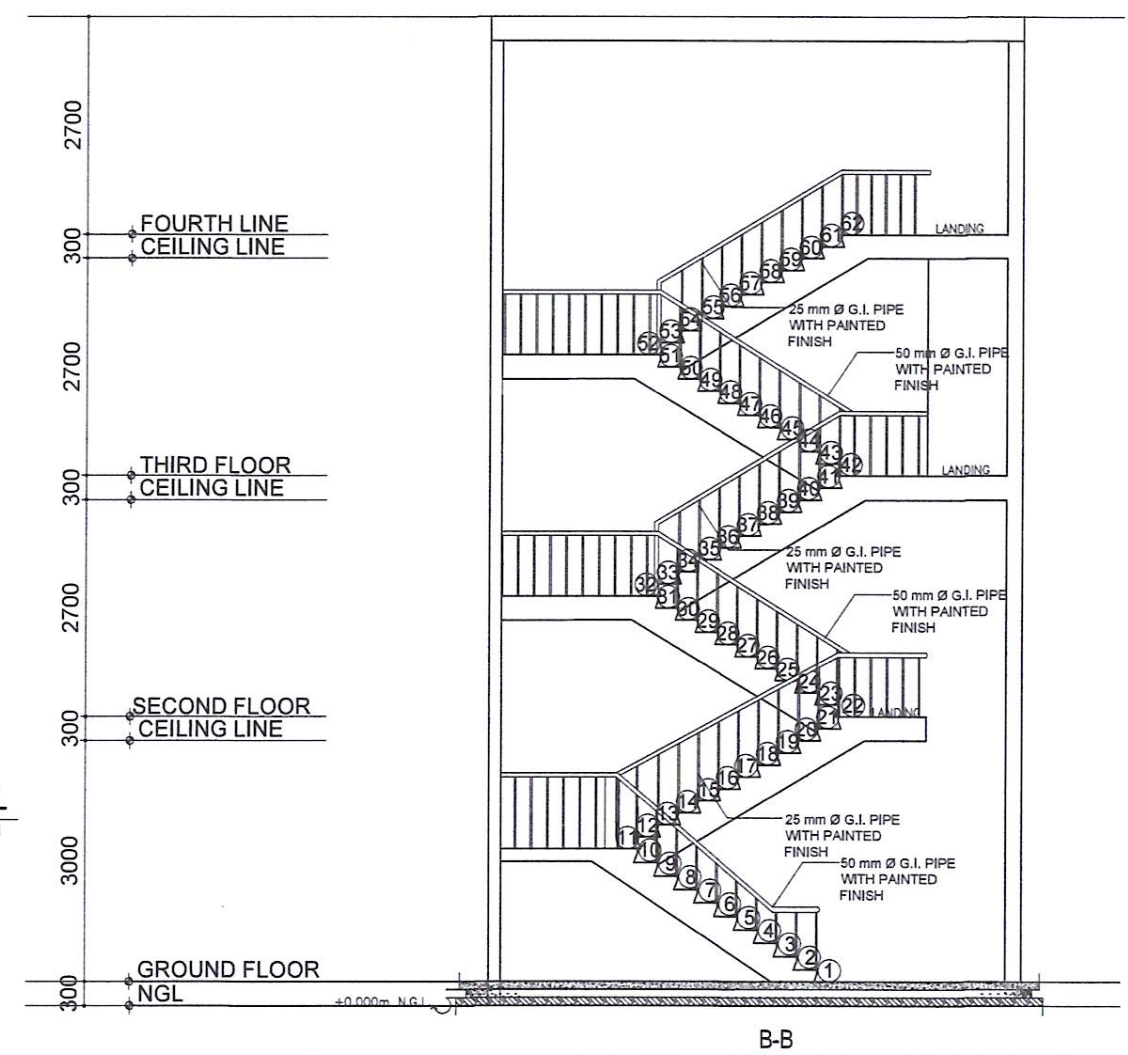

PROJECT TITLE:
PROPOSED TUPC DORMITORY

DESIGNED BY:
ENGR. BRYLLE EPHRAIEM Q. NAVARRO
IDO, CHAIRPERSON

APPROVED BY:
ENGR. ALEXANDER E. MAG-ISA, Ph.D., PME
CAMPUS DIRECTOR

DESIGNED BY:
IDO - CAVITE

CAD BY:

SHEET NO.
A 18

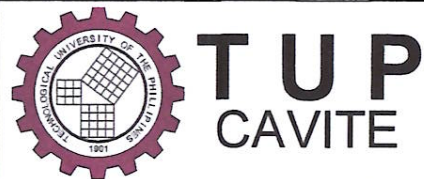
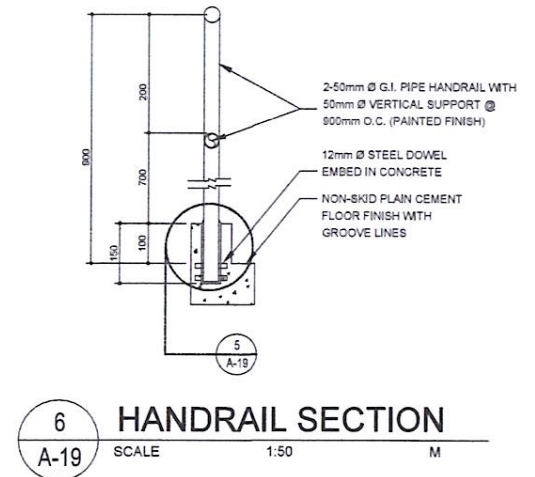
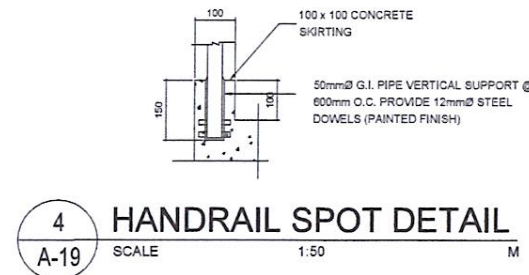
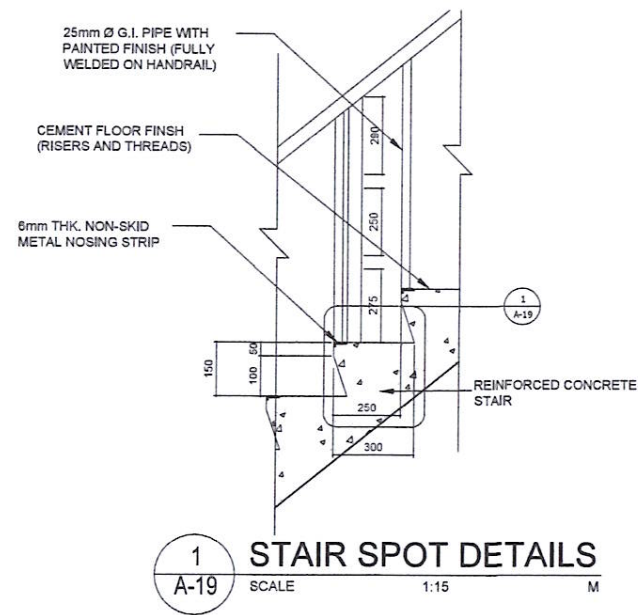
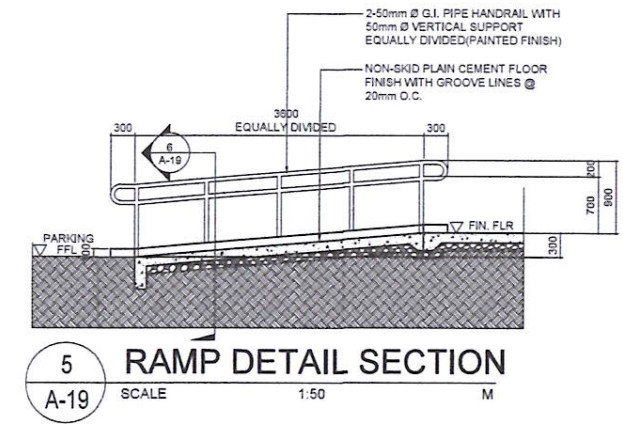
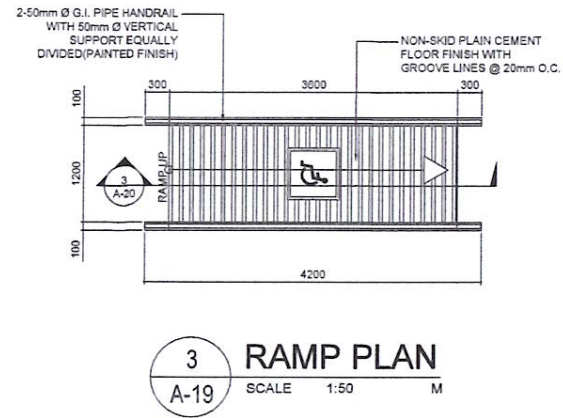
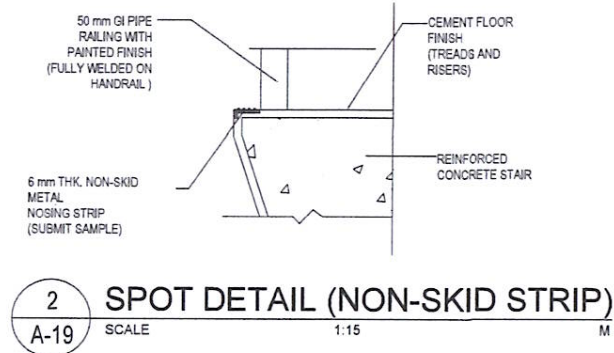

PROJECT TITLE:
PROPOSED TUPC DORMITORY

DESIGNED BY:
ENGR. BRYLLE EPHRAEM Q. NAVARRO
IDO, CHAIRPERSON

APPROVED BY:
ENGR. ALEXANDER E. MAG-ISA, Ph.D., PME
CAMPUS DIRECTOR

DESIGNED BY:
IDO - CAVITE

CAD BY:

SHEET NO.
A 19

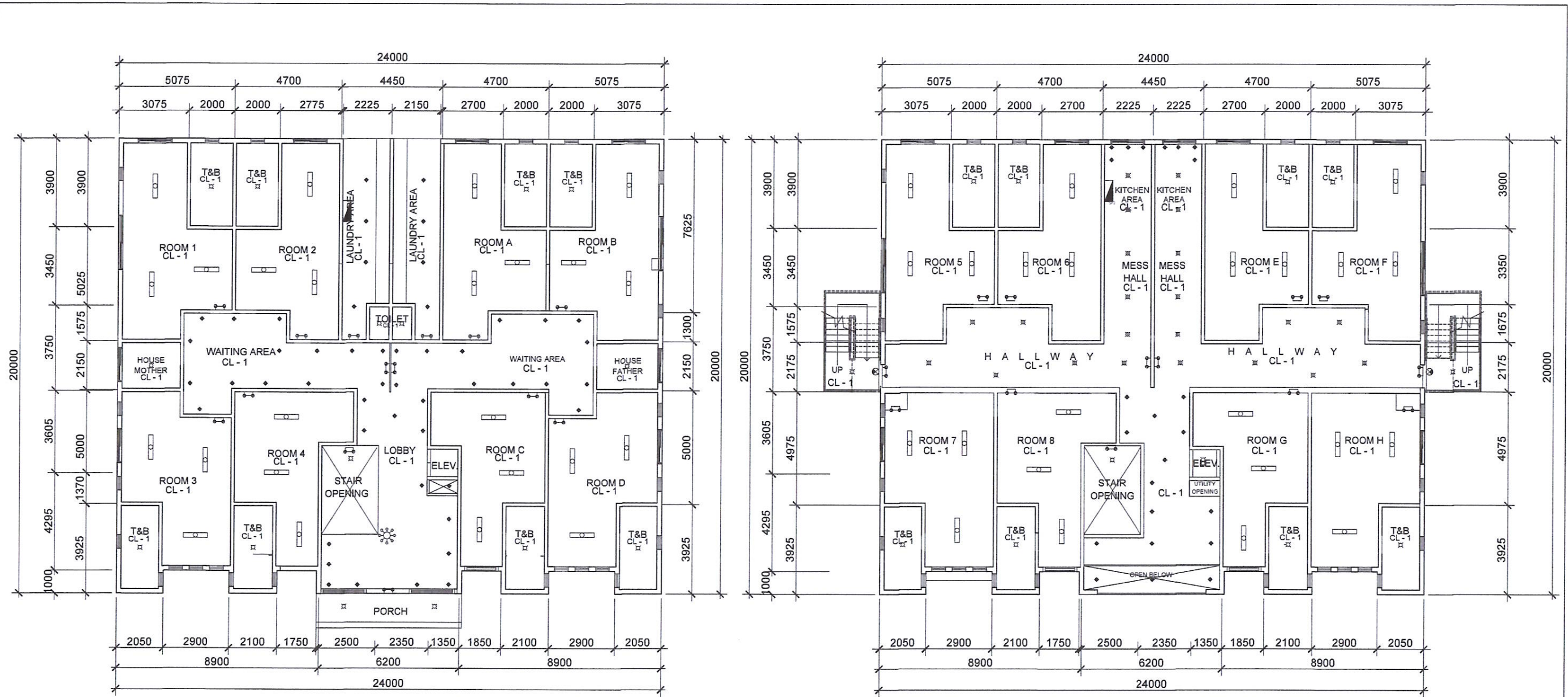

1
A-21
GROUND FLOOR PLAN
REFLECTIVE CEILING PLAN
SCALE 1:100 M

2
A-21
SECOND FLOOR
REFLECTIVE CEILING PLAN
SCALE 1:100 M

ELECTRICAL LEGENDS AND SYMBOLS	
⊠	RECESSED LIGHT
⊞	CEILING LIGHT
•	PIN LIGHT
⊠	LOUVER
⊙	EXIT SIGN
⊞	EMERGENCY LIGHT
—	COVE LIGHT
⊞	CHANDELIER
⊞	EXTERIOR LIGHT
⊞	LIGHT POST
⊞	AUTOMATIC EMERGENCY LIGHTING UNIT

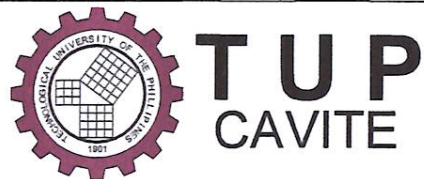

PROJECT TITLE:
PROPOSED TUPC DORMITORY

DESIGNED BY:
ENGR. BRYLLE EPHRAIEM Q. NAVARRO
IDO, CHAIRPERSON

APPROVED BY:
ENGR. ALEXANDER E. MAG-ISA, Ph.D., PME
CAMPUS DIRECTOR

DESIGNED BY:
IDO - CAVITE
CAD BY:

SHEET NO.
A 20

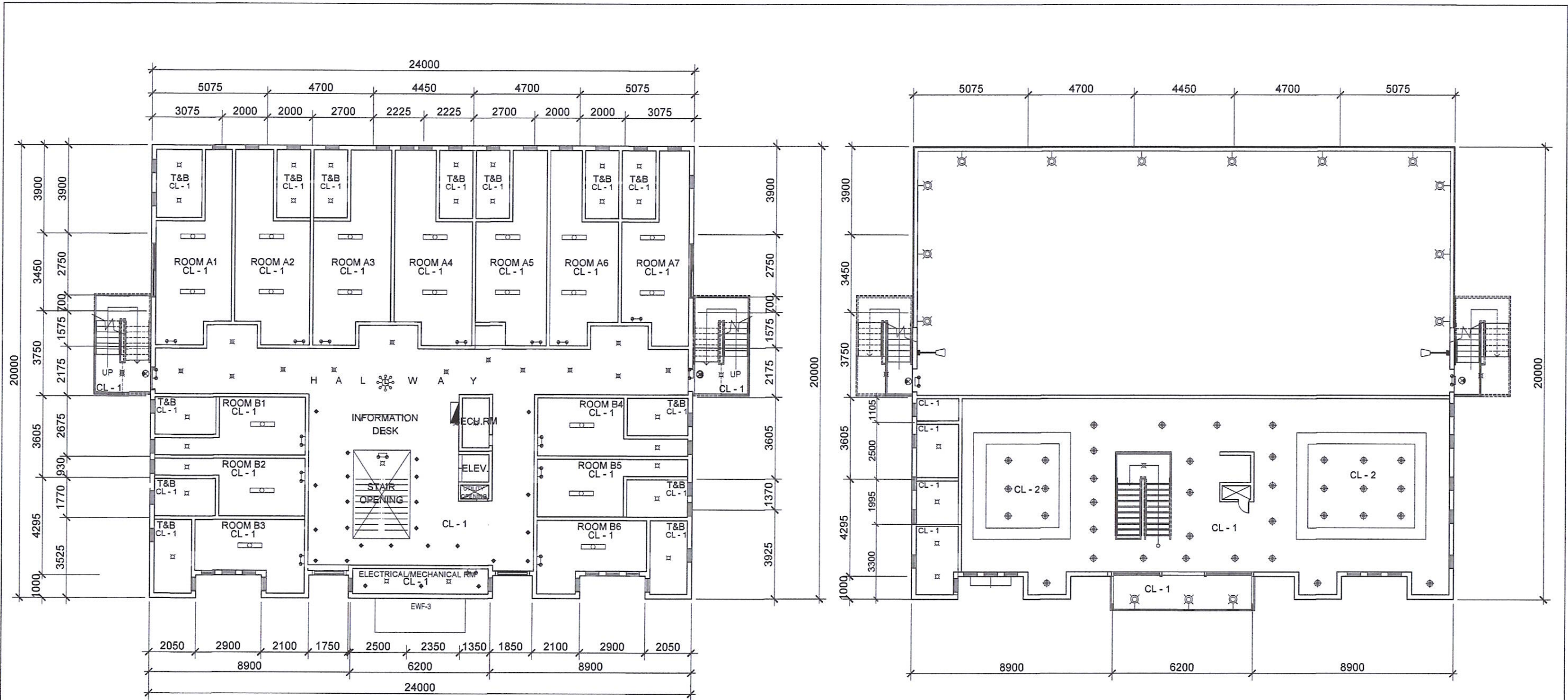

1
A-21
THIRD FLOOR PLAN
REFLECTIVE CEILING PLAN
SCALE 1:100 M

2
A-21
FOURTH FLOOR PLAN
REFLECTIVE CEILING PLAN
SCALE 1:100 M

ELECTRICAL LEGENDS AND SYMBOLS	
⊠	RECESSED LIGHT
⊞	CEILING LIGHT
•	PIN LIGHT
▭	LOUVER
⊙	EXIT SIGN
⚡	EMERGENCY LIGHT
—	COVE LIGHT
⊛	CHANDELIER
⊞	EXTERIOR LIGHT
⊞	LIGHT POST
⊞	AUTOMATIC EMERGENCY LIGHTING UNIT

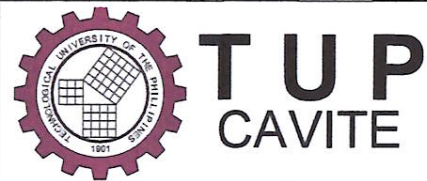

PROJECT TITLE:
PROPOSED TUPC DORMITORY

DESIGNED BY:
ENGR. BRYLLE EPHRAIEM Q. NAVARRO
IDO, CHAIRPERSON

APPROVED BY:
ENGR. ALEXANDER E. MAG-ISA, Ph.D., PME
CAMPUS DIRECTOR

DESIGNED BY:
IDO - CAVITE
CAD BY:

SHEET NO.
A 21

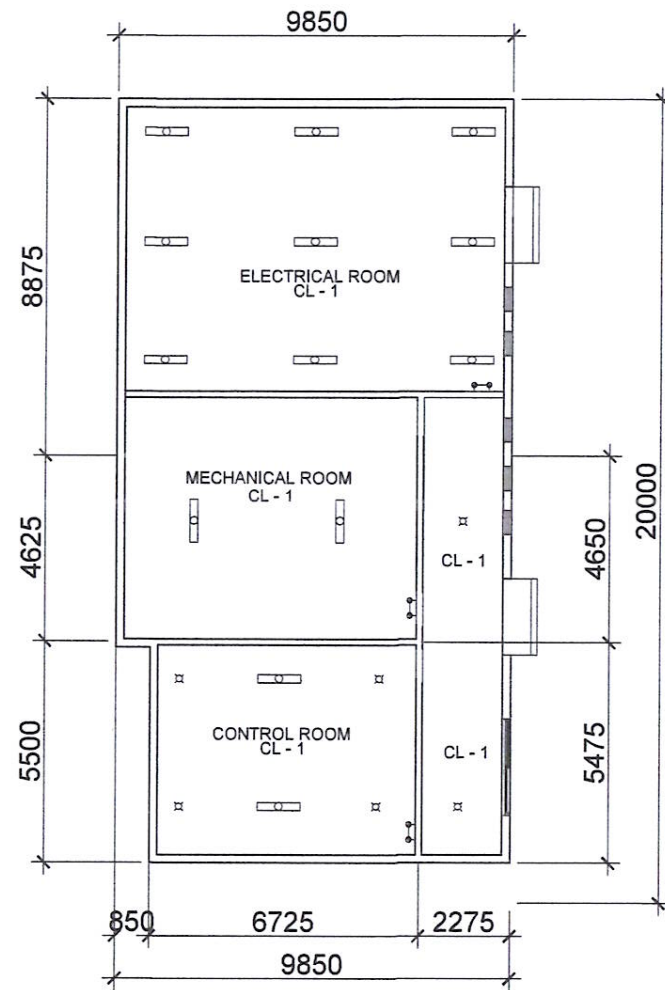

1 TUPC DORMITORY BUILDING
BASEMENT LIGHTING LAYOUT
 A-21 SCALE 1:100 M

SCHEDULE OF CEILING FINISHES	
CL-1	CEILING (4.5mm FIBER CEMENT BOARD ON METAL FRAME CEILING) - (PAINTED)
CL-2	COVE CEILING (PAINTED)

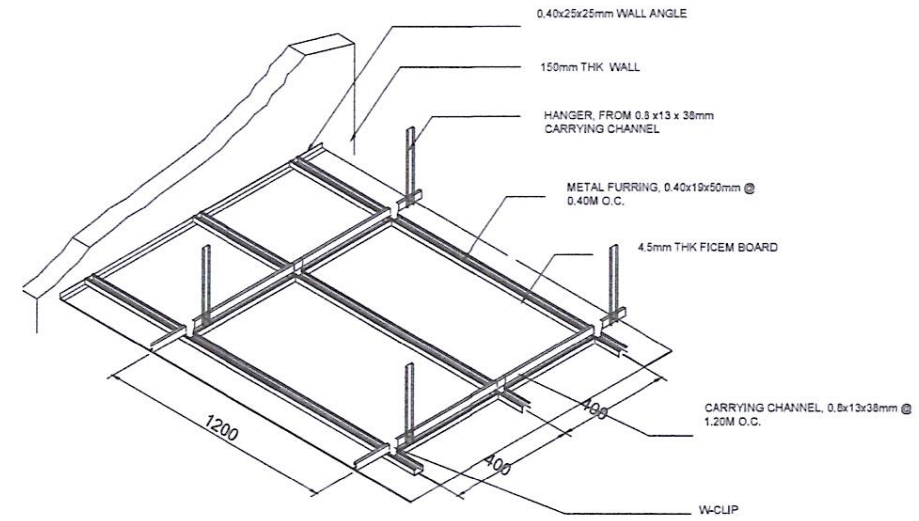

2 **CEILING DETAIL (ISOMETRIC)**
 A-21 NOT TO SCALE

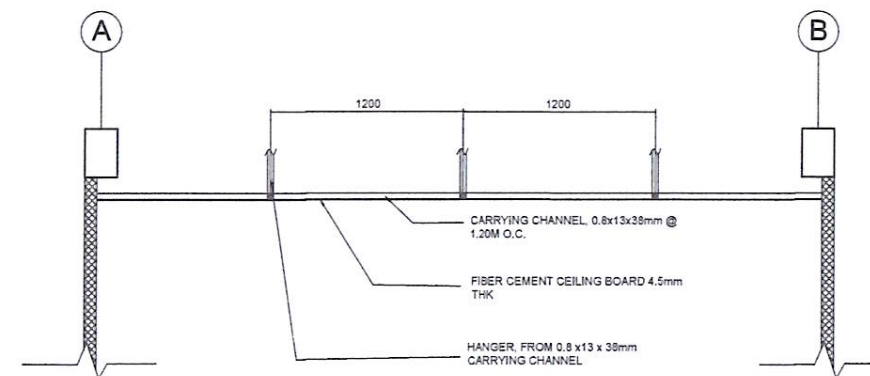

2 **CEILING SECTION DETAIL**
 A-21 SCALE 1:50 M

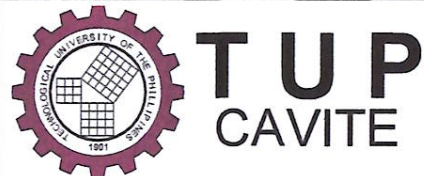

PROJECT TITLE:
PROPOSED TUPC DORMITORY

DESIGNED BY:
 ENGR. BRYLLE EPHRAEM Q. NAVARRO
 IDO, CHAIRPERSON

APPROVED BY:
 ENGR. ALEXANDER E. MAG-ISA, Ph.D., PME
 CAMPUS DIRECTOR

DESIGNED BY:
 IDO - CAVITE
 CAD BY:

SHEET NO.
A 22

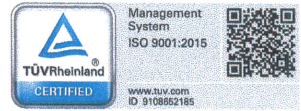

TUPC DORMITORY DETAILED STRUCTURAL PLAN

1.0 GENERAL :

- 1.1 ALL DIMENSIONS ARE SHOWN IN MILLIMETERS, ELEVATIONS ARE IN METERS, UNLESS NOTED OTHERWISE.
- 1.2 THE CONTRACTOR SHALL VERIFY ALL DIMENSIONS AND CONDITIONS AT THE SITE, AND SHALL NOTIFY THE ENGINEER OF DISCREPANCIES BETWEEN ACTUAL CONDITIONS AND INFORMATION SHOWN ON THE DRAWINGS BEFORE PROCEEDING WITH THE WORK. THIS SHALL INCLUDE THE LOCATIONS AND DIMENSIONS OF GROOVES, REGLETS, SLEEVES, CURBS, OPENINGS, EMBEDDED OR ATTACHED ITEMS, ETC. REFER TO ARCHITECTURAL, MECHANICAL, ELECTRICAL AND PLUMBING DRAWINGS.
- 1.3 ALL DIMENSIONS SHALL TAKE PRECEDENCE OVER SCALE SHOWN ON PLANS, SECTIONS OR DETAILS. NOTES AND DETAILS ON DRAWINGS SHALL TAKE PRECEDENCE OVER GENERAL NOTES AND TYPICAL DETAILS.
- 1.4 THE CONTRACTOR SHALL IMMEDIATELY NOTIFY THE OWNER AND/OR THE ENGINEER OF ANY CONDITION WHICH IN HIS OPINION MIGHT ENDANGER THE STABILITY OF THE STRUCTURES OR CAUSE DISTRESS IN THE STRUCTURES.
- 1.5 THE CONTRACTOR SHALL TAKE ALL STEPS NECESSARY TO ENSURE THE PROPER ALIGNMENT OF THE STRUCTURES AFTER THE INSTALLATION OF ALL STRUCTURAL AND FINISH MATERIALS.
- 1.6 CONTRACTOR SHALL BE RESPONSIBLE FOR THE COST OF ADDITIONAL WORK BY THE ENGINEER DUE TO SELECTION OF AN OPTION, SUBSTITUTION OF MATERIAL, OR DUE TO ERRORS OR OMISSION IN CONSTRUCTION BY CONTRACTOR.
- 1.7 SPECIAL NOTE: DIMENSIONS INDICATED ON THE STRUCTURAL DRAWINGS SHALL BE COORDINATED WITH THE ARCHITECTURAL DRAWINGS. ARCHITECTURAL DRAWINGS SHALL BE USED TO DEFINE DETAIL CONFIGURATIONS, ELEVATIONS, OPENINGS, JOINTS, SLOPES, ETC.
- 1.8 TYPICAL DETAILS AND GENERAL NOTES SHALL APPLY TO ALL PARTS OF THE JOB UNLESS OTHERWISE SHOWN ON THE DRAWINGS.

2.0 STANDARDS AND REFERENCES :

THE FOLLOWING SHALL GOVERN THE DESIGN, FABRICATION AND CONSTRUCTION OF THE PROJECT :

- 2.1 AMERICAN CONCRETE INSTITUTE (ACI PUBLICATIONS) :
 ACI 318-05 BLDG. CODE REQUIREMENTS FOR REINFORCED CONCRETE
 ACI 315-99 MANUAL OF STANDARD PRACTICE FOR DETAILS AND DETAILING OF CONCRETE REINFORCEMENT.
 ACI 301-05 STANDARD SPECIFICATION FOR STRUCTURAL CONCRETE
- 2.2 NATIONAL STRUCTURAL CODE OF THE PHILIPPINES (NSCP) VOL. 1, FIFTH EDITION, 2001.

3.0 BASIC DESIGN LOADS

3.1 DEAD LOADS, (D)

REINFORCED CONCRETE	24.0	kN/m ³
STRUCTURAL STEEL	77.0	kN/m ³
SOIL	18.0	kN/m ³
WATER	9.81	kN/m ³
CERAMIC TILE FLOOR FINISH	1.00	kPa
CEMENT FILL FINISH	0.70	kPa
100mm THICK CHB WALL	2.11	kPa
150mm THICK CHB WALL	2.73	kPa
CEILING	0.15	kPa
MECHANICAL & ELECTRICAL FIXTURES	0.25	kPa
MISCELLANEOUS		
MEMBRANE WATERPROOFING	0.26	kPa

3.2 OCCUPANCY LIVE LOADS, (L)

ROOF	1.0	kPa
BEDROOMS	1.9	kPa

3.3 WIND LOAD (W)

WIND LOADS ARE CALCULATED IN ACCORDANCE WITH NSCP 2001 VOLUME 1 FIFTH EDITION WITH A MINIMUM BASIC WINDSPEED OF 200 KPH (ZONE II - EXPOSURE B).

3.4 SEISMIC LOAD (E)

SEISMIC LOAD FOR BUILDINGS ARE CALCULATED IN ACCORDANCE WITH NSCP 2001 VOLUME 1 FIFTH EDITION.

SEISMIC DESIGN PARAMETERS ARE AS FOLLOWS :

SEISMIC SOURCE TYPE	C
SOIL PROFILE TYPE	S ₁
SEISMIC COEFFICIENT, C _a	0.34 N _a
C _v	0.64 N _v
NEAR SOURCE FACTOR, N _a	1.0
N _v	1.0
SEISMIC ZONE FACTOR (ZONE 4)	Z = 0.40
IMPORTANCE FACTOR	I = 1.0
NUMERICAL COEFF. (NSCP TABLE 208-11)	R = 8.5 (SMRF)

4.0 MATERIALS :

4.1 NORMAL WEIGHT CONCRETE :

- 4.1.1 CONCRETE USED IN THIS WORK, UNLESS OTHERWISE STATED ON PLANS, SHALL BE READY-MIX AND HAVE A MINIMUM COMPRESSIVE STRENGTH @ 28 DAYS OF:
 f_c' = 34.50 MPa ALL STRUCTURAL MEMBERS
 f_c' = 20.69 MPa FOR SLAB ON GRADE (INCLUDING GUTTER) EXCEPT SPECIFIED BELOW
 f_c' = 7.0 MPa FOR LEAN CONCRETE
- 4.1.2 ALL CONCRETE SHALL BE DEPOSITED, VIBRATED AND CURED IN ACCORDANCE WITH ACI STANDARD 318-05.
- 4.1.3 MIN CONCRETE COVER FOR REINFORCING BARS SHALL BE AS FOLLOWS:
 A. FOUNDATION = 75 MM (CAST AGAINST EARTH)
 B. BEAMS AND COLUMNS = 40 MM (TO STIRRUPS AND TIES)
 C. WALLS = 25 MM (CAST AGAINST FORMS)
 D. SUSPENDED SLABS = 20 MM

4.2 REINFORCING BARS :

- 4.2.1 REINFORCING STEEL SHALL BE DEFORMED AND SHALL MEET PNS/ASTM A615. THE MINIMUM YIELD STRENGTH SHALL BE AS FOLLOWS:
 FOR #10 AND SMALLER:
 f_y = 276 MPa
 FOR #12 AND LARGER:
 f_y = 414 MPa
- 4.2.2 ALL REINFORCING BARS SHALL BE CLEAN OF RUST, GREASE OR OTHER MATERIALS WHICH TEND TO IMPAIR BOND.
- 4.2.3 ALL REINFORCING BARS SHALL BE ACCURATELY AND SECURELY PLACED BEFORE POURING CONCRETE OR APPLYING MORTAR OR GROUT.
- 4.2.4 LAPPED SPLICES SHALL BE STAGGERED WHERE POSSIBLE.
- 4.2.5 UNLESS INDICATED OTHERWISE, SPlicing OF REINFORCEMENT SHALL BE IN ACCORDANCE WITH ACI STANDARD 318-08 AND SHALL NOT EXCEED THAT SPECIFIED IN ITEM 4.2.12.
- 4.2.6 UNLESS INDICATED OTHERWISE, ALL BEAMS TERMINATING AT THE COLUMN SHALL HAVE TOP AND BOTTOM BARS EXTENDING TO THE FAR FACE OF THE COLUMN, TERMINATING IN A STANDARD 90° HOOK, LENGTH OF ANCHORAGE SHALL NOT BE LESS THAN 8d_b OR 150MM.
- 4.2.7 SHOP DRAWINGS FOR BENDING AND CUTTING OF REINFORCEMENT SHALL BE SUBMITTED FOR APPROVAL TO THE ENGINEER PRIOR TO FABRICATION.
- 4.2.8 CLEAR SPACING BETWEEN REINFORCING BARS SHALL NOT BE LESS THAN:
 1.5d_b NOR 40MM FOR COLUMNS
 1.0d_b NOR 25MM FOR OTHER MEMBERS

4.2.9 UNLESS SHOWN OTHERWISE ON PLANS, SPLICES SHALL BE AS FOLLOWS :

- A. BEAMS AND FOOTING TIE BEAMS :
 AT LEAST TWO EXTRA STIRRUPS-TIES SHALL BE PROVIDED AT ALL SPLICES. THE SPLICE LENGTH SHALL NOT BE LESS THAN THE LENGTH IN TABLE OF LAP SPLICE BELOW.
- B. COLUMNS : SPLICES WHEN PERMITTED SHALL BE MADE WITHIN THE CENTER HALF OF COLUMN HEIGHT, AND THE LAP SPLICE SHALL NOT BE LESS THAN LD SPECIFIED IN TABLE OF LAP SPLICE. THE USE OF APPROVED MECHANICAL DEVICES MAY BE PERMITTED PROVIDED THAT NOT MORE THAN ALTERNATE BARS ARE SPLICED AT ANY LEVEL AND THE MINIMUM VERTICAL DISTANCE BETWEEN TWO ADJACENT BAR SPLICES SHALL BE 600MM.
- C. CHB WALLS : VERTICAL BARS SHALL BE SPLICED AT THE TOP OF WALL FOOTING OR TIE BEAM AND AT THE BOTTOM OF RC LINTEL BEAM OR BEAMS.

4.2.10 WELDING OF REINFORCEMENT IS NOT PERMITTED UNLESS OTHERWISE SHOWN ON THE DRAWINGS. WELDING OF REINFORCEMENT SHALL CONFORM TO AWS D1.4. ASTM A706 SHALL BE USED FOR WELDED REINFORCING STEEL. REINFORCEMENT NOT CONFORMING TO ASTM A706 MAY BE USED IF MATERIAL PROPERTIES OF THE REPLACEMENT STEEL CONFORM TO AWS D1.4.

4.2.11 DEVELOPMENT AND SPLICE LENGTHS OF REINFORCEMENT BARS SHALL BE AS FOLLOWS: BE SUBMITTED FOR APPROVAL TO THE ENGINEER PRIOR TO FABRICATION.

4.3 CONCRETE HOLLOW BLOCK UNITS (CHB) :

- 4.3.1 CHB USED IN THESE WORKS SHALL HAVE A MINIMUM ULTIMATE COMPRESSIVE STRENGTH @ 28 DAYS OF f_m' = 2.5 MPa (350 PSI) 100/150 MM THICK NON-LOAD BEARING CHB.
- 4.3.2 ALL CELLS SHALL BE SOLIDLY FILLED WITH CONCRETE MORTAR, CONCRETE MORTAR SHALL HAVE A MINIMUM COMPRESSIVE STRENGTH OF 17.20 MPa (2500 PSI) @ 28 DAYS.

5.0 FORMWORKS :

- 5.1 FORMS SHALL BE PROVIDED FOR ALL CONCRETE NOT INDICATED OF SPECIFIED OTHERWISE. THE CONTRACTOR SHALL BE RESPONSIBLE FOR THE ADEQUACY OF FORMS AND FORM SUPPORTS. ALL FORMWORKS SHALL BE PROVIDED WITH ADEQUATE CLEAN-OUT OPENINGS TO PERMIT INSPECTION AND EASY CLEANING AFTER ALL REINFORCEMENT HAS BEEN PLACED. ALL FORMS SHALL BE CONSTRUCTED SO THAT THEY CAN BE REMOVED WITHOUT DAMAGING THE CONCRETE.
 - 5.2 FORMS SHALL BE REMOVED IN A MANNER WHICH WILL PREVENT DAMAGE TO THE CONCRETE. FORMS SHALL NOT BE REMOVED, WITHOUT APPROVAL OF THE ENGINEER, OR BEFORE EXPIRATION OF THE MINIMUM PANELS SPECIFIED HEREIN:
- | | DAYS AFTER PLACING |
|---|--------------------|
| FOUNDATION | 1 |
| SUSPENDED SLAB EXCEPT WHEN ADDITIONAL LOADS ARE IMPOSED | 8 |
| FORMS FOR COLUMNS (LIFTS OVER 4.5M) | 7 |
| SUPPORTING FORMS FOR SLABS, BEAMS, GIRDERS | 14 |
- SUFFICIENT SHORING TO SUPPORT THE DEAD LOAD PLUS CONSTRUCTION LOADS ON BEAMS, GIRDERS AND SLABS SHALL BE PROVIDED FOR A PERIOD OF 14 DAYS IN ADDITION TO THE 14 DAYS SPECIFIED HEREIN, PROVIDED ALL CONCRETE TEST RESULTS HAS SHOWN SUFFICIENT STRENGTH FOR 28 DAYS.

6.0 CAMBER REQUIREMENTS :

- 6.1 UNLESS OTHERWISE NOTED ON THE PLANS OR SPECIFICATIONS CAMBER ALL RC BEAMS AT LEAST 10mm. FOR EVERY 4000mm. OF CLEAR SPAN EXCEPT CANTILEVERS WHICH SHALL BE 50mm. FOR EVERY 3000mm. OF CLEAR SPAN.
- 6.2 UNLESS OTHERWISE NOTED IN PLANS OR SPECIFICATIONS, CAMBER ALL SLABS 8mm PER 3000mm. OF SHORTER SPAN AND 14mm. FOR EVERY 2000mm. OF SLABS CANTILEVER SPAN

7.0 FOUNDATIONS :

- 7.1 ALL FOOTINGS/FOUNDATIONS WERE DESIGNED USING ASSUMED GROSS ALLOWABLE SOIL BEARING CAPACITY OF 143 KPa AT DEPTHS INDICATED IN THE DRAWING. CONFIRMATION OF ACTUAL SOIL BEARING CAPACITY SHALL BE DONE PRIOR TO CONSTRUCTION OF FOUNDATION. INCREASE IN FOUNDATION SIZE SHALL BE DONE WHEN ACTUAL SOIL BEARING CAPACITY CONFIRMED DURING EXCAVATION WARRANT REVISION OF FOUNDATION SIZES.
- 7.2 FOR FOOTINGS AND FOUNDATIONS RESTING ON FILL, THE FILL MATERIALS UNDERNEATH SHALL BE SELECTED STRUCTURAL FILL CLASSIFIED AS GW, GP, SW, SP OF THE TECHNICAL SPECIFICATION SECTION 02221. PLACE AND COMPACT FILL IN ACCORDANCE WITH THE ABOVE TECHNICAL SPECIFICATIONS.
- 7.3 WHERE LOOSE/SOFT MATERIAL IS ENCOUNTERED AT DEPTH OF FOOTING/FOUNDATION INDICATED, EXCAVATE TO FIRM LAYER AND REPLACE LOOSE/SOFT MATERIALS UNDERNEATH THE FOOTING WITHIN THE FOOTING AREA PLUS 1/2 DEPTH OF SOIL MATERIAL ON ALL SIDES WITH SELECTED BACKFILL. COMPACT SELECTED BACKFILL TO 95% MAXIMUM DRY DENSITY (ASTM D1557).
- 7.4 FILL/BACKFILL SHALL BE PLACED IN 200MM LAYERS AND EACH LAYER SHALL BE COMPACTED TO 95% MAXIMUM DRY DENSITY BEFORE SUBSEQUENT LAYERS ARE TO BE LAID.
- 7.5 ALL EQUIPMENT FOUNDATIONS SHALL REST ON A 50MM LEAN CONCRETE ON A WELL COMPACTED SUBGRADE. SLAB ON GRADE AND OTHER STRUCTURAL ELEMENTS SHALL REST ON A 150MM COMPACTED GRAVEL BEDDING UNLESS OTHERWISE NOTED.

TABLE OF LAP SPLICE

PARAMETERS											
MATERIAL	fy	f _c	ACI 318-08	DEVT & SPLICE LENGTH	TENSION LAP SPLICE (mm)						UNIT WT. (kg/m ³)
	MPa	MPa			LAP CLASS	TOP BAR	BOTTOM BAR	TIE	COLUMN	SPIRAL	
F _c	5000	34.5			A	440	340	340	340		0.616
f _y	60000	414		12mm & HIGHER	B	570	440	340	410	410	0.888
f _{yh}	40000	276		10mm & LOWER	A	690	530	540	540	540	1.579
d _b	10				A	700	540	540	540	540	1.579
	40000				B	910	700	700	700	700	2.466
					A	890	680	680	680	680	2.466
					B	1140	890	890	890	890	2.466
					A	1370	1050	1060	1060	1060	3.854
					B	1780	1380	1380	1380	1380	4.833
					A	1540	1180	1180	1180	1180	4.833
					B	2000	1530	1530	1530	1530	6.313
					A	1760	1350	1350	1350	1350	6.313
					B	2290	1760	1760	1760	1760	6.313
					A	1980	1520	1520	1520	1520	7.991
					B	2670	1980	1980	1980	1980	7.991

NOTES:
 1. DEVELOPMENT LENGTH OF INDIVIDUAL BARS WITH A BUNDLE, IN TENSION OR COMPRESSION, SHALL BE THAT FOR INDIVIDUAL BARS, INCREASED 20% FOR THREE-BUNDLED AND 33% FOR FOUR-BUNDLED BARS.
 2. FOR COLUMNS AT ANY LEVEL, NO MORE THAN ALTERNATE BARS SHOULD BE SPLICED, NOT MORE THAN 33% OF THE BARS SHALL BE SPLICED WITHIN THE REQUIRED LAP LENGTH. MINIMUM DISTANCE BETWEEN TWO ADJACENT SPLICES SHALL BE 600mm.
 3. TOP BARS ARE HORIZONTAL BARS WITH MORE THAN 300mm DEPTH OF CONCRETE CAST BELOW REINFORCEMENT.
 4. LAP SPLICE SHALL BE "CLASS B" TENSION LAP SPLICE IF MORE THAN ONE HALF OF THE BARS WERE SPLICED AT ANY SECTION, WHILE "CLASS A" TENSION LAP SPLICE IF HALF OR FEWER THAN HALF OF BARS WERE SPLICED.
 5. TOP BARS SPLICE FOR BEAMS, SHOULD BE "BEAM COMPRESSIVE SPLICE x1.3"

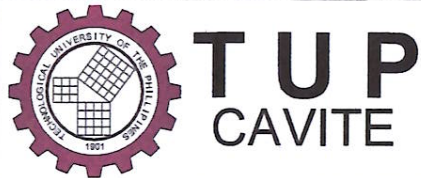

PROJECT TITLE:
PROPOSED TUPC DORMITORY

DESIGNED BY:
ENGR. BRYLLE EPARAIEM Q. NAVARRO
 IDO, CHAIRPERSON

APPROVED BY:
ENGR. ALEXANDER E. MAG-ISA, Ph.D., PME
 CAMPUS DIRECTOR

DESIGNED BY:
IDO - CAVITE

CAD BY:

SHEET NO.
S 1

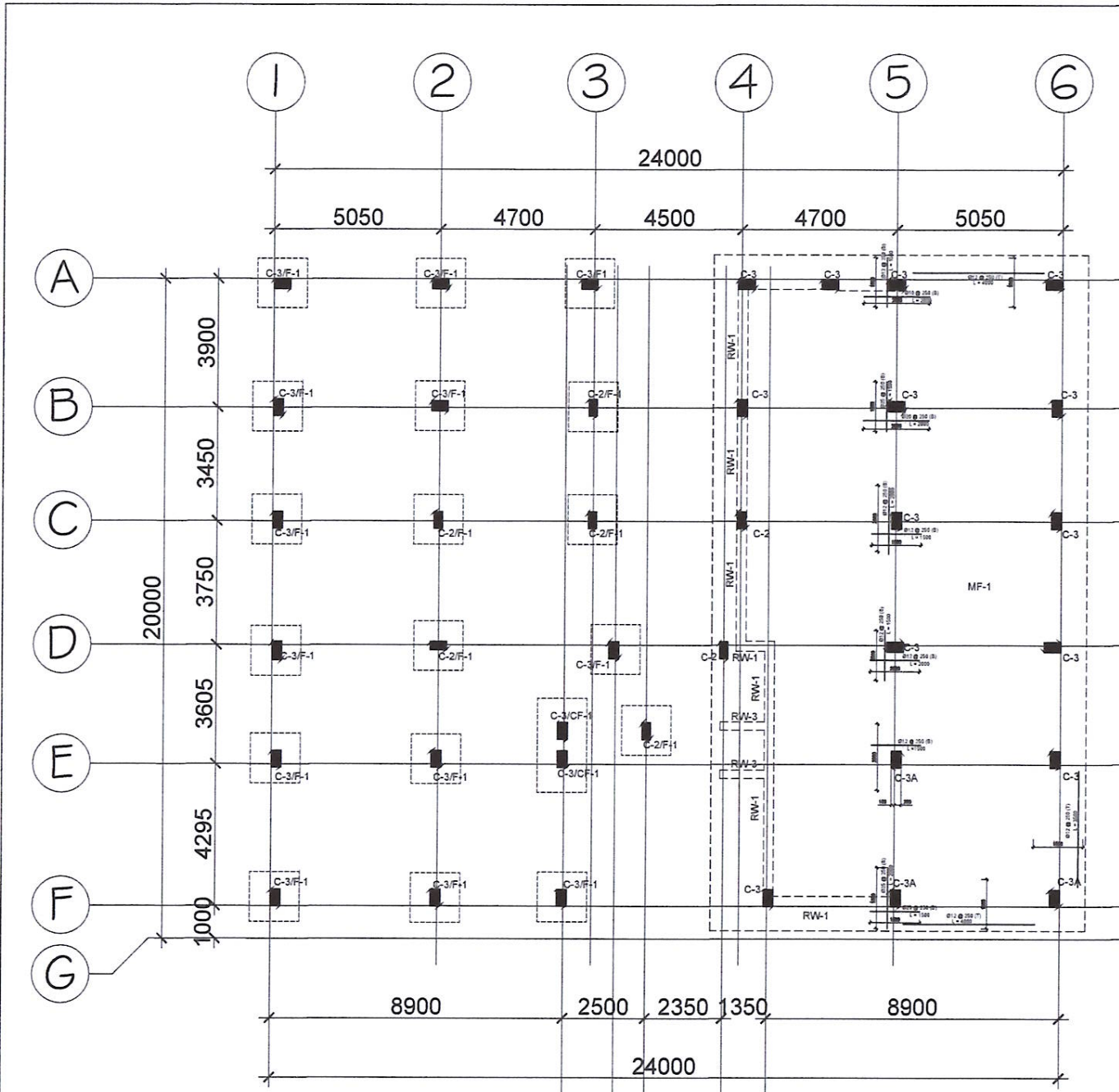

1 DORMITORY BUILDING
FOUNDATION PLAN
S-02 SCALE 1:100 M

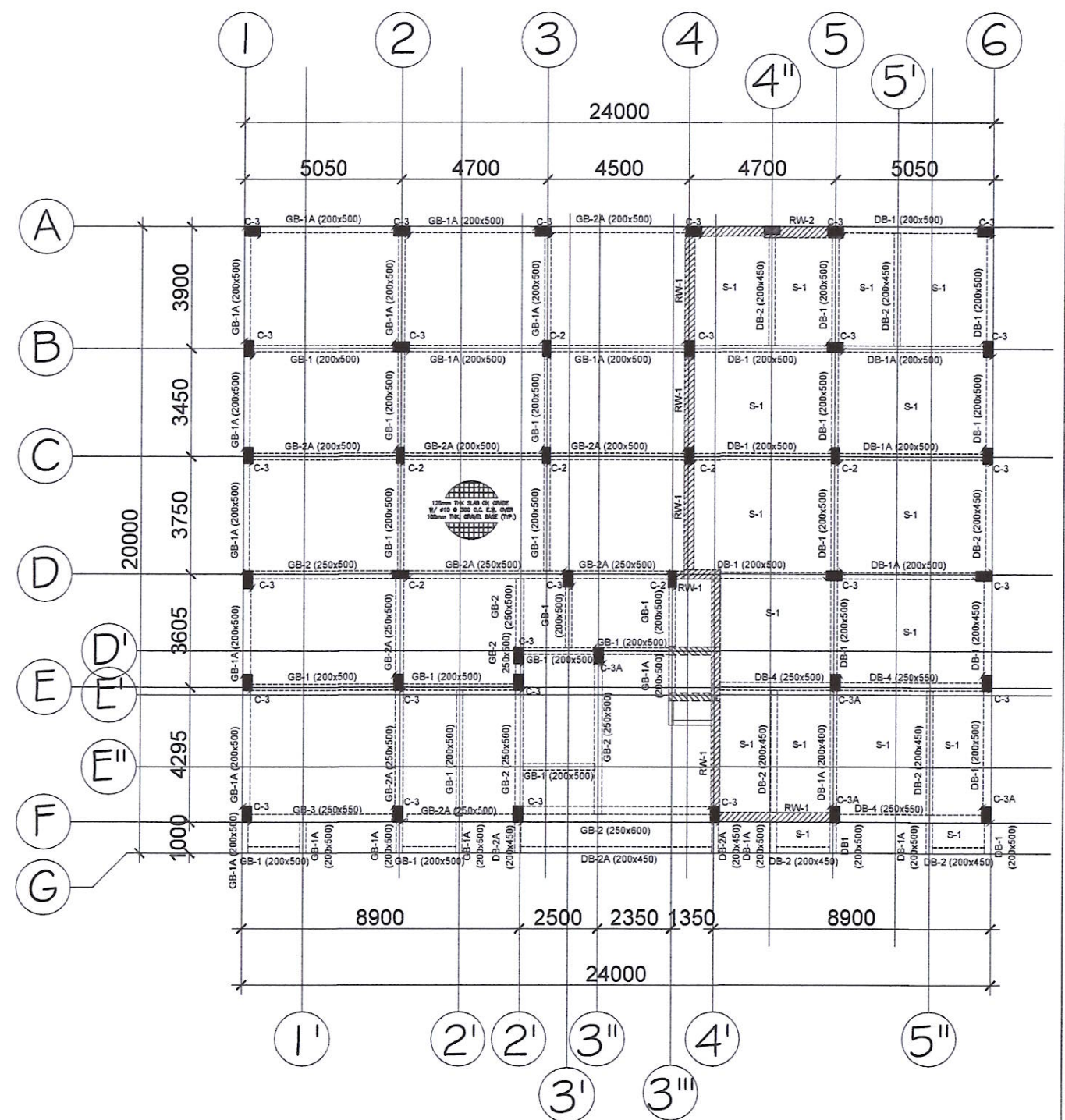

2 DORMITORY BUILDING
GROUND FLOOR FRAMING PLAN
S-02 SCALE 1:100 M

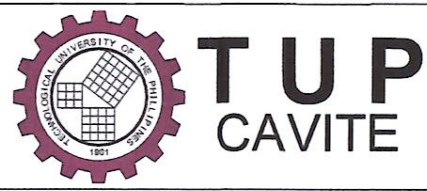

PROJECT TITLE:
PROPOSED TUPC DORMITORY

DESIGNED BY:
ENGR. BRYLLE EPHRAIEM Q. NAVARRO
IDO, CHAIRPERSON

APPROVED BY:
ENGR. ALEXANDER E. MAG-ISA, Ph.D., PME
CAMPUS DIRECTOR

DESIGNED BY:
IDO - CAVITE
CAD BY:

SHEET NO.
S 2

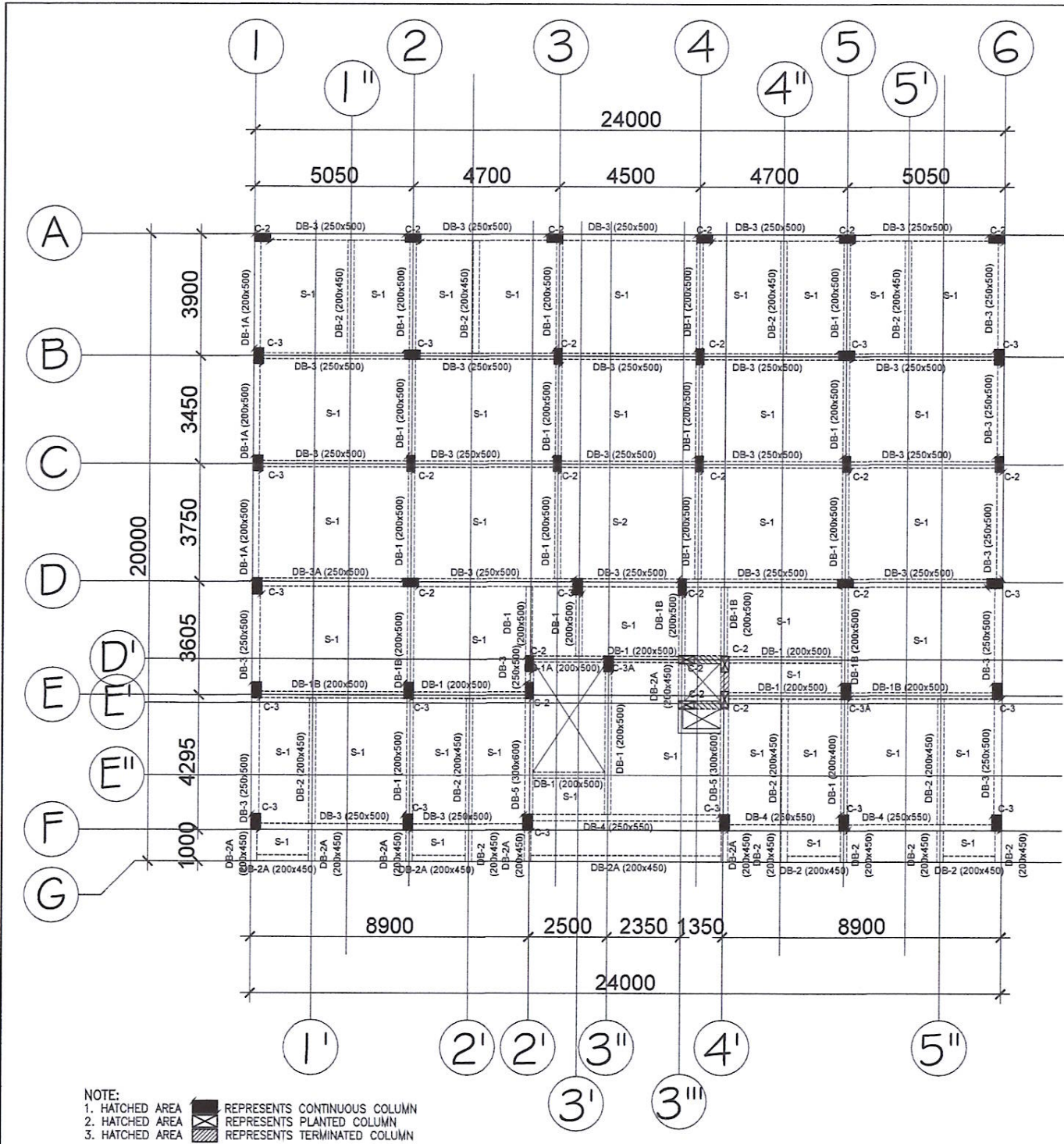

1
S-03
DORMITORY BUILDING
SECOND FLOOR FRAMING PLAN
SCALE 1:100 M

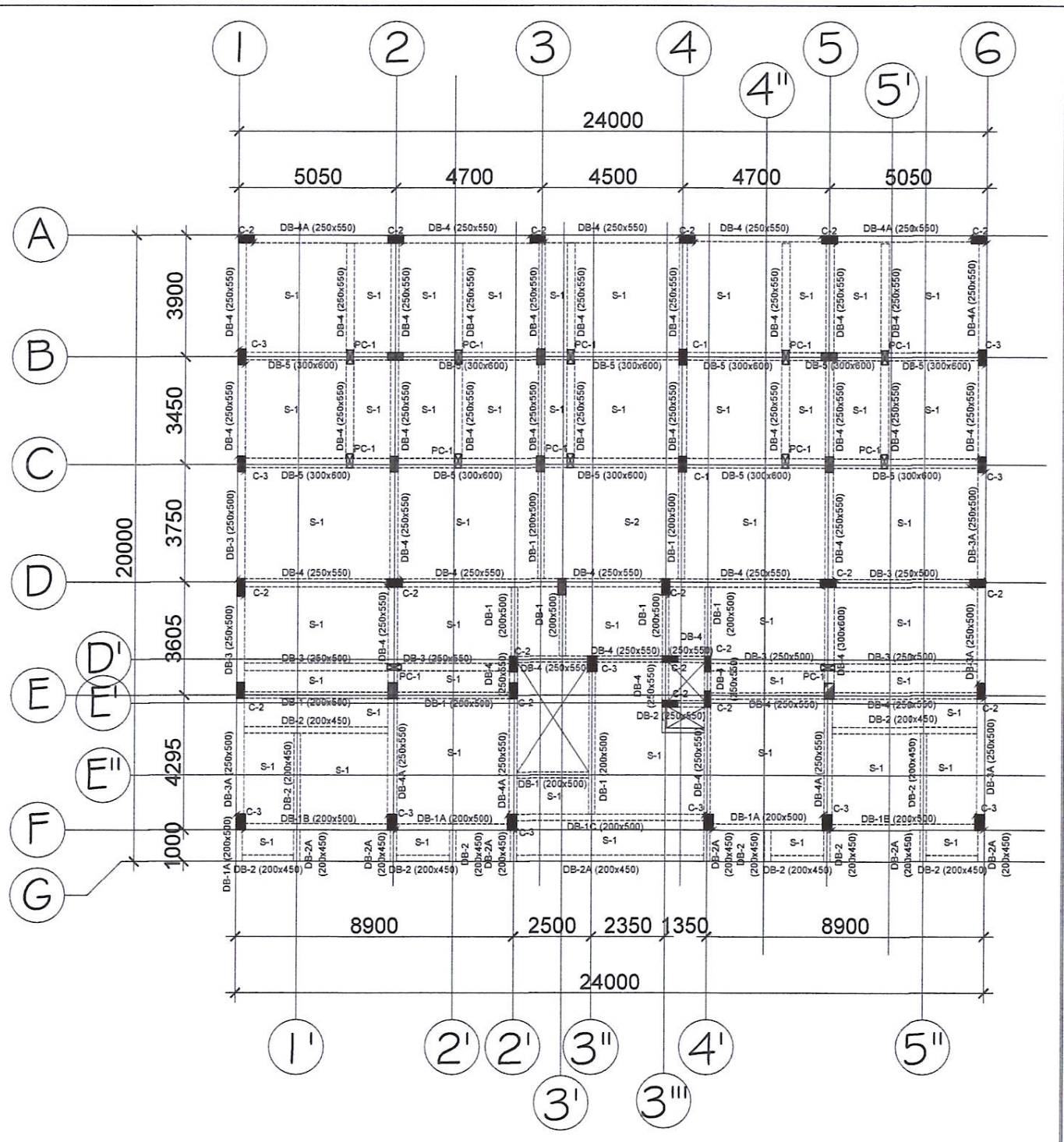

2
S-03
DORMITORY BUILDING
THIRD FLOOR FRAMING PLAN
SCALE 1:100 M

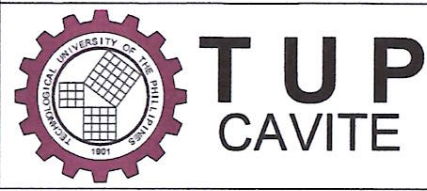

PROJECT TITLE:
PROPOSED TUPC
DORMITORY

DESIGNED BY:
ENGR. BRYLLE EPHRAIEM Q. NAVARRO
IDO, CHAIRPERSON

APPROVED BY:
ENGR. ALEXANDER E. MAG-ISA, Ph.D., PME
CAMPUS DIRECTOR

DESIGNED BY:
IDO - CAVITE
CAD BY:

SHEET NO.
S 3

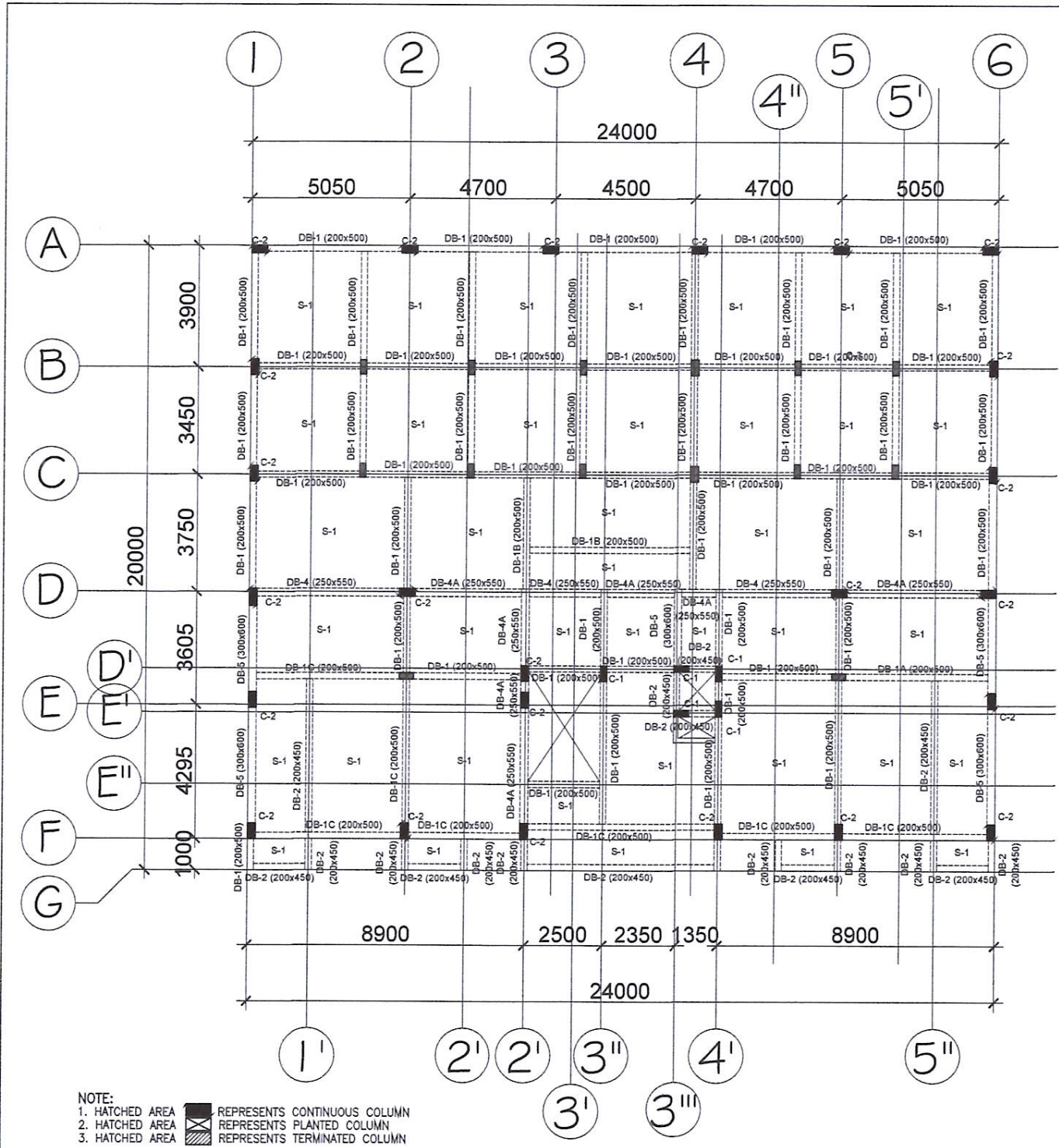

1
S-04
DORMITORY BUILDING
ROOF DECK FRAMING PLAN
SCALE 1:100 M

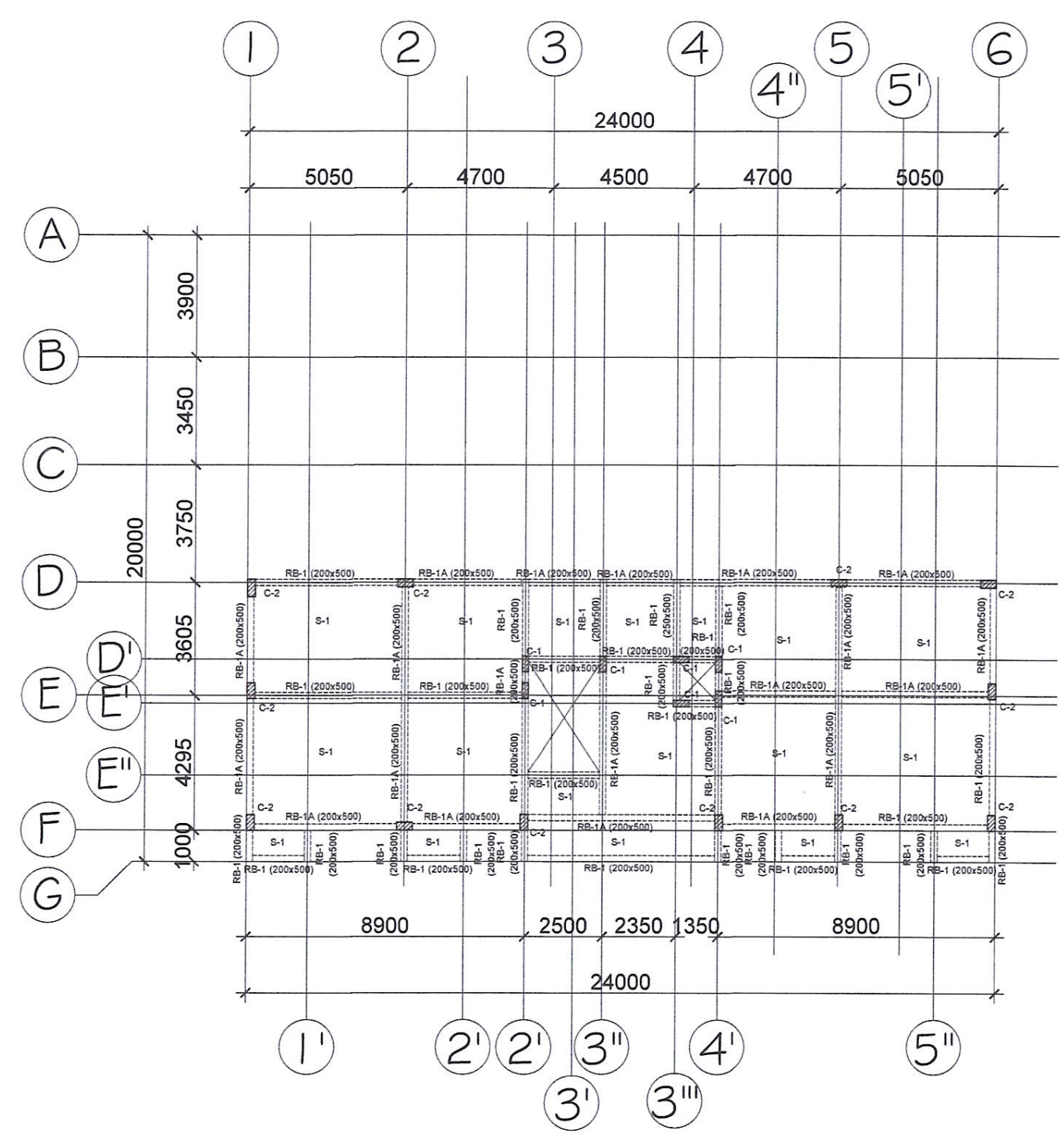

2
S-04
DORMITORY BUILDING
ROOF FRAMING PLAN
SCALE 1:100 M

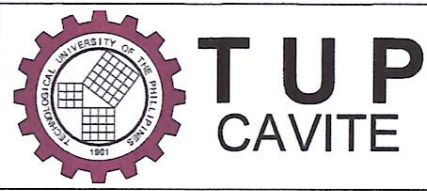

PROJECT TITLE:
PROPOSED TUPC DORMITORY

DESIGNED BY:
ENGR. BRYLLE EPITRAIEM Q. NAVARRO
IDO, CHAIRPERSON

APPROVED BY:
ENGR. ALEXANDER E. MAG-ISA, Ph.D., PME
CAMPUS DIRECTOR

DESIGNED BY:
IDO - CAVITE
CAD BY:

SHEET NO.
S 4

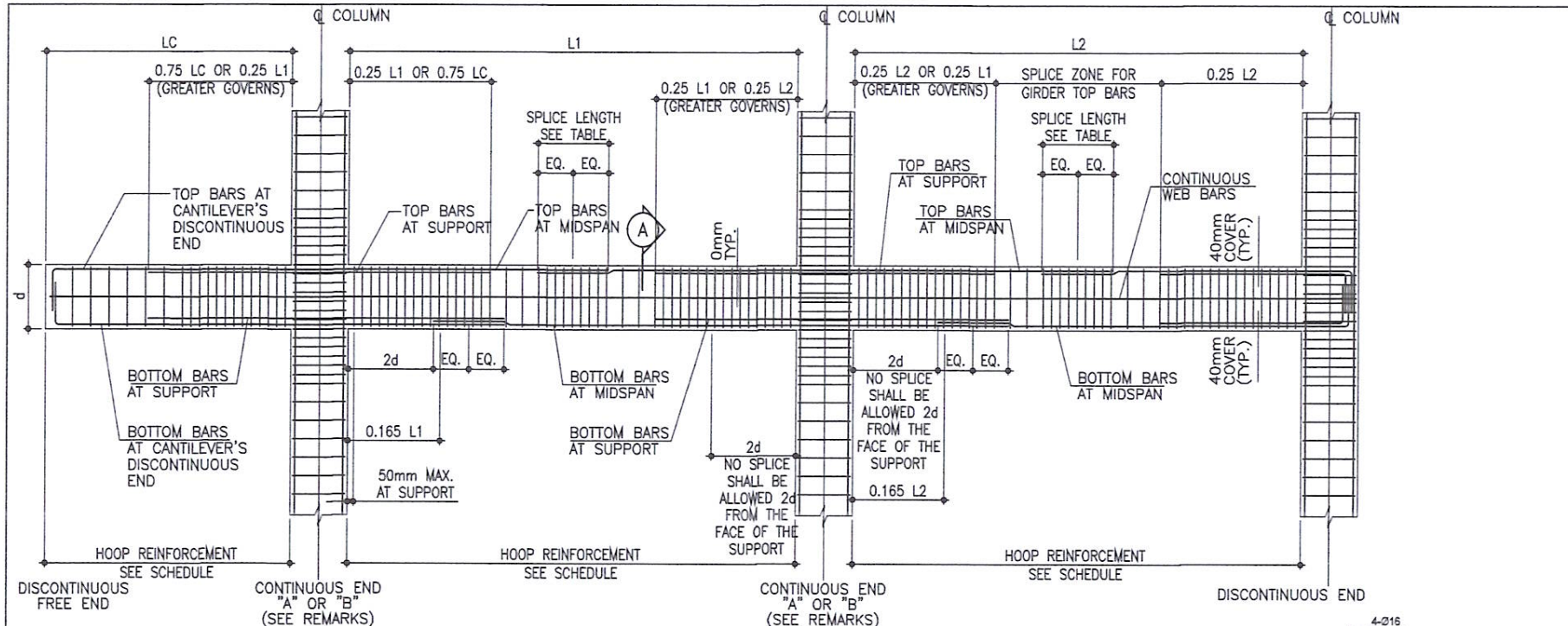

ELEVATION

NOTE: AT INTERIOR SUPPORT (CONTINUOUS END) PROVIDE LARGER SIZE AND LARGER NUMBER OF TOP AND BOTTOM BARS FROM ADJACENT SPAN.
NO SPLICE SHALL OCCUR ON CANTILEVER BEAMS

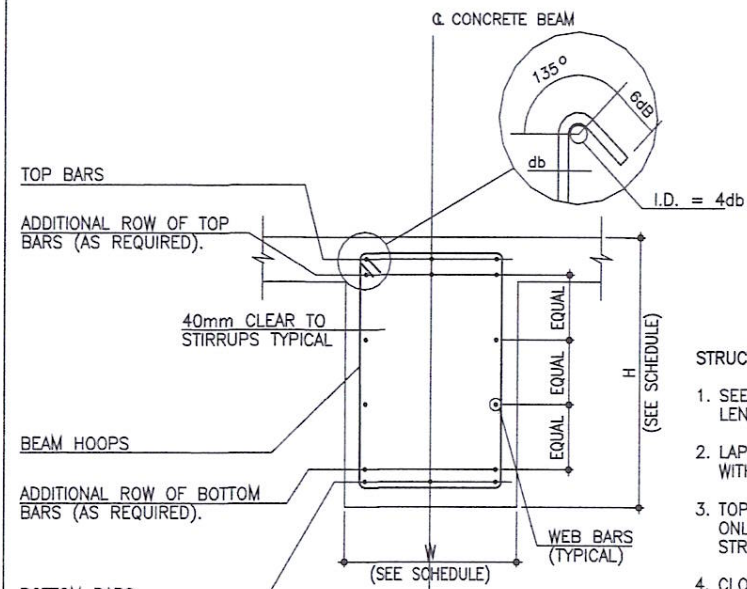

SECTION

- STRUCTURAL NOTES :
- SEE TABLE OF LAP SPLICE & ANCHORAGE LENGTHS SHOWN ON SHEET
 - LAP SPLICE SHALL BE LOCATED ONLY WITHIN THE LAP SPLICE ZONE.
 - TOP & BOTTOM BARS MAY BE LAP SPICED ONLY ON ONE LOCATION FOR EACH STRING OF BEAMS.
 - CLOSED HOOPS WITH A 135° BEND SHALL BE SPACED AT 100 O.C. MAXIMUM AT A DISTANCE 2D FROM THE FACE OF THE SUPPORT. FIRST STIRRUP SHALL 5D FROM THE FACE OF THE SUPPORT.

NOTE: SLAB REINFORCEMENT NOT SHOWN FOR CLARITY

1 DORMITORY BUILDING
TYPICAL DUCTILE MOMENT FRAME BEAM DETAIL
S-05 SCALE NTS

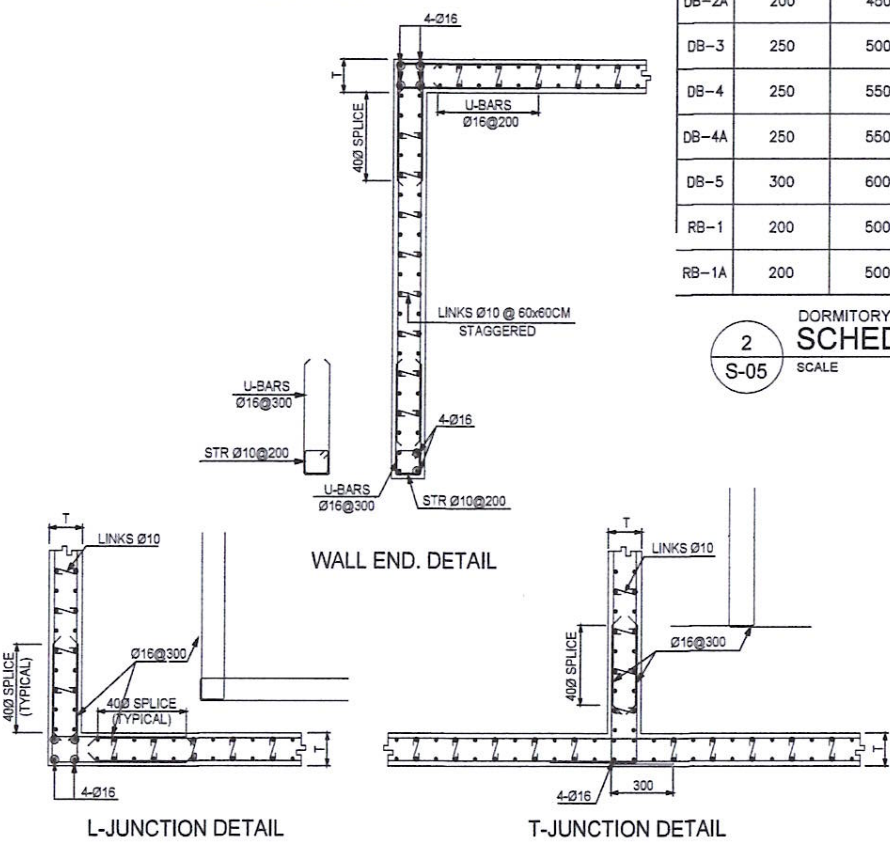

L-JUNCTION DETAIL

WALL END DETAIL

T-JUNCTION DETAIL

3 DORMITORY BUILDING
TYPICAL WALL REINFORCEMENT DETAIL IN PLAN
S-05 SCALE NTS

SCHEDULE OF REINFORCED CONCRETE BEAMS

BEAM DESIG.	DIMENSIONS (mm)		REINFORCEMENT (mm)		SIZE & SPACING OF STIRRUPS	
	B	D	CONT.	ADD'L BAR	SUPPORT	MIDSPAN
GB-1	200	500	2-#16mm		#10 □, 1Ø50, REST Ø 150	#10 □ @ 200
GB-1A	200	500	2-#20mm		#10 □, 1Ø50, REST Ø 150	#10 □ @ 200
GB-2	250	500	2-#20mm		#10 □, 1Ø50, REST Ø 150	#10 □ @ 200
GB-2A	250	500	3-#16mm		#10 □, 1Ø50, REST Ø 150	#10 □ @ 200
GB-3	250	550	3-#20mm		#10 □, 1Ø50, REST Ø 150	#10 □ @ 200
DB-1	200	500	3-#16mm		#10 □, 1Ø50, REST Ø 150	#10 □ @ 200
DB-1A	200	500	2-#20mm		#10 □, 1Ø50, REST Ø 100	#10 □ @ 150
DB-1B	200	500	2-#20mm	2-#16mm	#10 □, 1Ø50, REST Ø 150	#10 □ @ 200
DB-1C	200	500	2-#20mm	2-#16mm	#10 □, 1Ø50, REST Ø 100	#10 □ @ 150
DB-2	200	450	2-#16mm		#10 □, 1Ø50, REST Ø 150	#10 □ @ 200
DB-2A	200	450	2-#20mm		#10 □, 1Ø50, REST Ø 100	#10 □ @ 150
DB-3	250	500	2-#20mm	2-#12mm	#10 □, 1Ø50, REST Ø 150	#10 □ @ 200
DB-4	250	550	3-#16mm	2-#12mm	#10 □, 1Ø50, REST Ø 100	#10 □ @ 150
DB-4A	250	550	3-#16mm	2-#12mm	#10 □, 1Ø50, REST Ø 100	#10 □ @ 150
DB-5	300	600	3-#20mm	2-#16mm	#10 □, 1Ø50, REST Ø 100	#10 □ @ 150
RB-1	200	500	3-#20mm	2-#16mm	#10 □, 1Ø50, REST Ø 150	#10 □ @ 200
RB-1A	200	500	2-#20mm	2-#12mm	#10 □, 1Ø50, REST Ø 100	#10 □ @ 150

2 DORMITORY BUILDING
SCHEDULE OF REINFORCED CONCRETE BEAMS
S-05 SCALE NTS

LEVELS	REINFORCEMENT	REINFORCED CONCRETE WALL SCHEDULE		
		RW1	RW2	RW3
GROUND TO SECOND FLOOR	VERTICAL (E.F.)	-	-	Ø16@300
	HORIZONTAL (E.F.)	-	-	Ø10@200
PASEMENT/FOUNDATION TO GROUND FLOOR	VERTICAL (E.F.)	Ø16@200	Ø16@300	Ø16@300
	HORIZONTAL (E.F.)	Ø12@300	Ø12@300	Ø10@200
THICKNESS (MM)		300	350	250
	WALL MARK	RW1	RW2	RW3
NOTE		REINFORCED CONCRETE WALL SCHEDULE		

4 DORMITORY BUILDING
SCHEDULE OF R.C. WALL
S-05 SCALE NTS

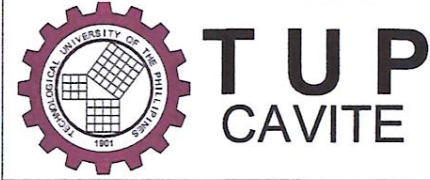

PROJECT TITLE:
PROPOSED TUPC DORMITORY

DESIGNED BY:
ENGR. BRYLLE EPHRAIEM Q. NAVARRO
IDO, CHAIRPERSON

APPROVED BY:
ENGR. ALEXANDER E. MAG-ISA, Ph.D., PME
CAMPUS DIRECTOR

DESIGNED BY:
IDO - CAVITE
CAD BY:

SHEET NO.
S 5

SCHEDULE OF COLUMNS					
COL. MARK	C-1	C-2	C-3	C-3A	PC-1
FLOOR LEVEL					
VARIOUS LEVELS (SEE FRAMING PLANS)					
SIZE	200x500	250x500	300x500	300x500	200x450
VERT. REINF.	6-#20MM	8-#20MM	8-#20MM	10-#20MM	6-#16MM
TIES (a)	2-#10 @ 150MM	2-#10 @ 150MM	2-#10 @ 150MM	2-#10 @ 150MM	2-#10 @ 150MM
CONFIN. REINF. (b)	2-#10 @ 100MM	2-#10 @ 100MM	2-#10 @ 100MM	2-#10 @ 100MM	2-#10 @ 100MM
JOINT REINF. (c)	2-#10 @ 100MM	2-#10 @ 100MM	2-#10 @ 100MM	2-#10 @ 100MM	2-#10 @ 100MM

NOTE: FOR TIES, "N"=#10 @ 100MM, "N" MEANS NO. OF PCS. SEE TIES LAYOUT ABOVE.

1 DORMITORY BUILDING
SCHEDULE OF COLUMNS
SCALE NTS

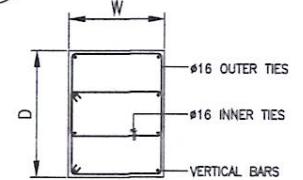

2 DORMITORY BUILDING
COMBINATION OF TIES
SCALE NTS

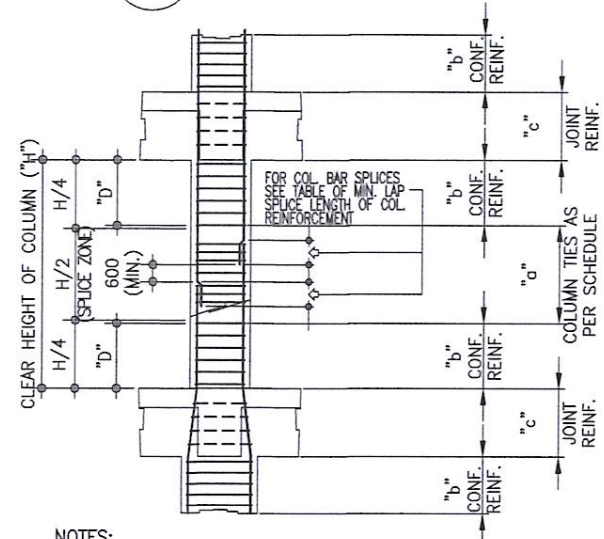

- NOTES:
1. YIELD STRESS OF HOOPS = 60/40 KSI
 2. D = USE MAXIMUM COLUMN/SHEARWALL DIMENSION, 1/6 CLEAR HEIGHT OR 18" (450mm) WHICHEVER IS GREATER.
 3. NUMBER OF HOOP TIES SAME AS PER COLUMN/SHEARWALL TIES SCHEDULE.
 4. ALL CONCRETE REINFORCEMENT DETAIL SHOULD BE DONE IN ACCORDANCE WITH ACI DETAILING MANUAL 1980 PUB SP-66
 5. SPACING OF TIES WITHIN THE SPLUCE SHOULD BE @_100mm

3 DORMITORY BUILDING
TYPICAL COLUMN ELEVATION
SCALE NTS

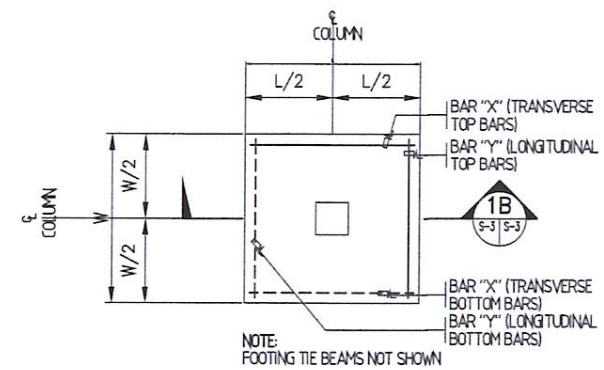

3 DORMITORY BUILDING
TYPICAL FTG. DETAIL
SCALE NTS

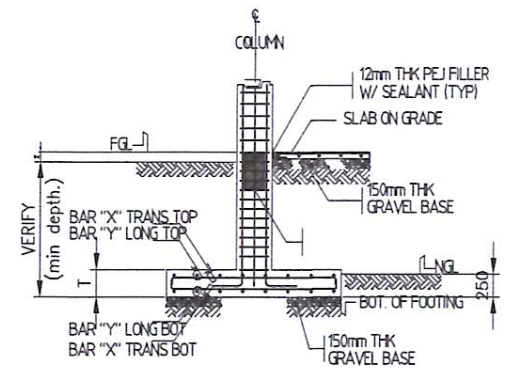

4 DORMITORY BUILDING
SECTION
SCALE NTS

SCHEDULE OF FOOTINGS						
FOOTING DESIG.	DIMENSIONS (mm)				REINFORCEMENT (mm)	REMARKS
	D (DEPTH)	W (WIDTH)	L (LENGTH)	T THICKNESS		
F-1	3000	1500	1500	300	TB - #16@200 B.W. BB	ISOLATED FOOTING
CF-1	1500	1500	2850	300	TB - #16@200 B.W. BB	COMBINED FOOTING
MF-1	VERIFY	SEE FOUNDATION PLAN		450	TB - #16@250 B.W. BB - #16@250 B.W.	MATT FOOTING

NOTE: SEE COLUMN LOCATION IN FRAMING PLAN FOR COMBINED AND CANTILEVER FOOTINGS.

6 DORMITORY BUILDING
SCHEDULE OF FOOTINGS
SCALE NTS

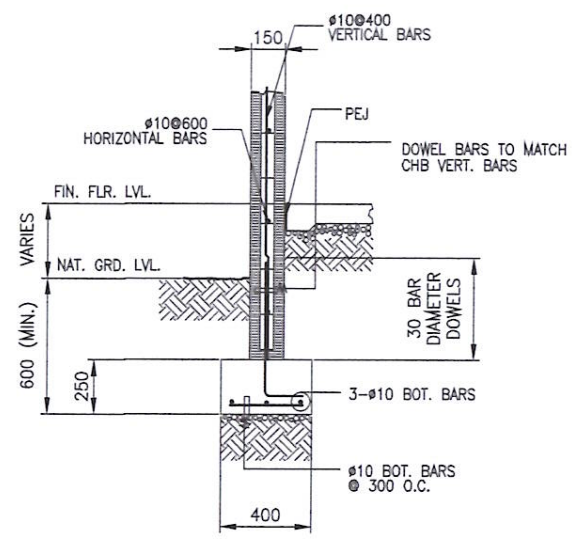

3 DORMITORY BUILDING
TYPICAL WALL FTG. DETAIL
SCALE NTS

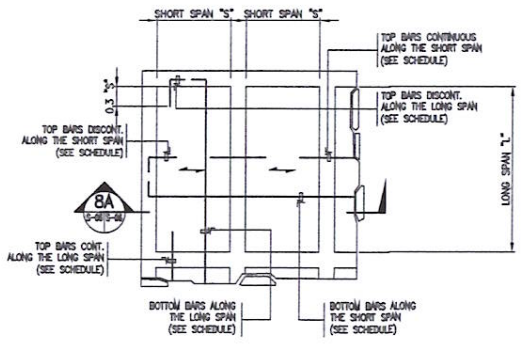

7 DORMITORY BUILDING
TYP. ONE WAY RC SLAB DETAIL
SCALE NTS

SCHEDULE OF SLAB REINFORCEMENT							
SLAB MARK	THICKNESS (mm)	BAR DIA.	SHORT SPAN		LONG SPAN		REMARKS
			TOP BAR DISCONT.	BOTTOM BAR CONT.	TOP BAR DISCONT.	BOTTOM BAR CONT.	
S-1	100	#12	200	200	200	200	SEE FRAMING PLANS
S-2	100	#16	150	150	150	150	SEE FRAMING PLANS

6 DORMITORY BUILDING
SCHEDULE OF SLAB
SCALE NTS

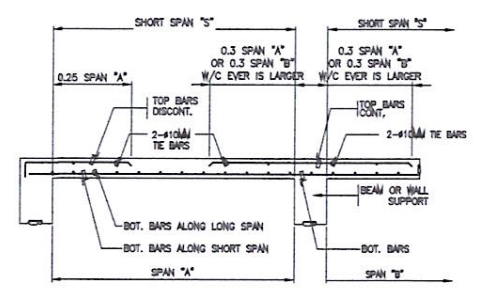

8A SECTION
SCALE NOT TO SCALE

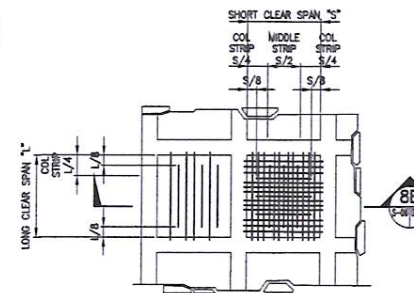

TYP. FRAMING PLAN OF TWO WAY SLAB SHOWING BOTTOM BAR REINFORCEMENT

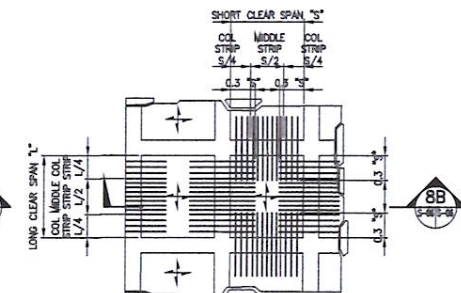

TYP. FRAMING PLAN OF TWO WAY SLAB SHOWING TOP BAR REINFORCEMENT

8 DORMITORY BUILDING
TYP. TWO WAY RC SLAB DETAIL
SCALE NTS

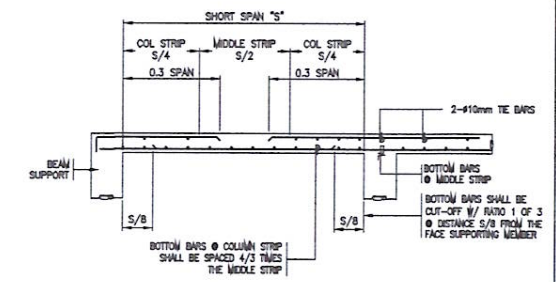

8B SECTION
SCALE NOT TO SCALE

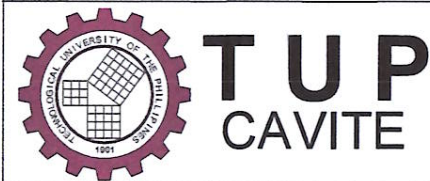

PROJECT TITLE:
PROPOSED TUPC DORMITORY

DESIGNED BY:
ENGR. BRYLLE EPHRAEM Q. NAVARRO
IDO, CHAIRPERSON

APPROVED BY:
ENGR. ALEXANDER E. MAG-ISA, Ph.D., PME
CAMPUS DIRECTOR

DESIGNED BY:
IDO - CAVITE
CAD BY:

SHEET NO.
S 6



TUPC DORMITORY DETAILED ELECTRICAL PLAN

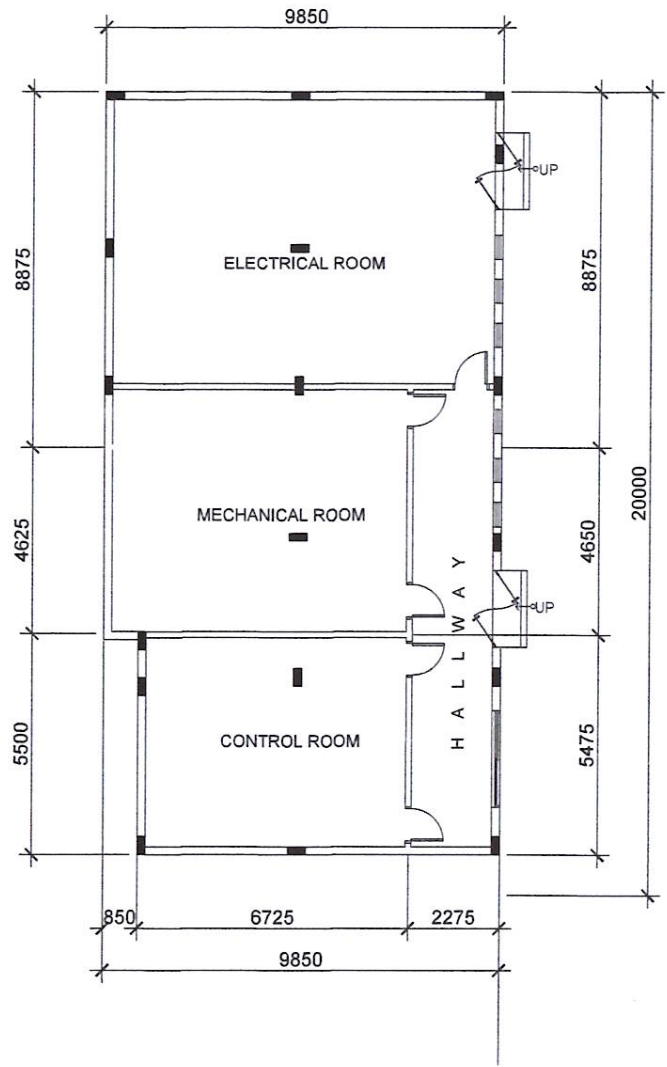

DORMITORY BUILDING
1 BASEMENT FLOOR PLAN
 A-6 SCALE 1:100 M

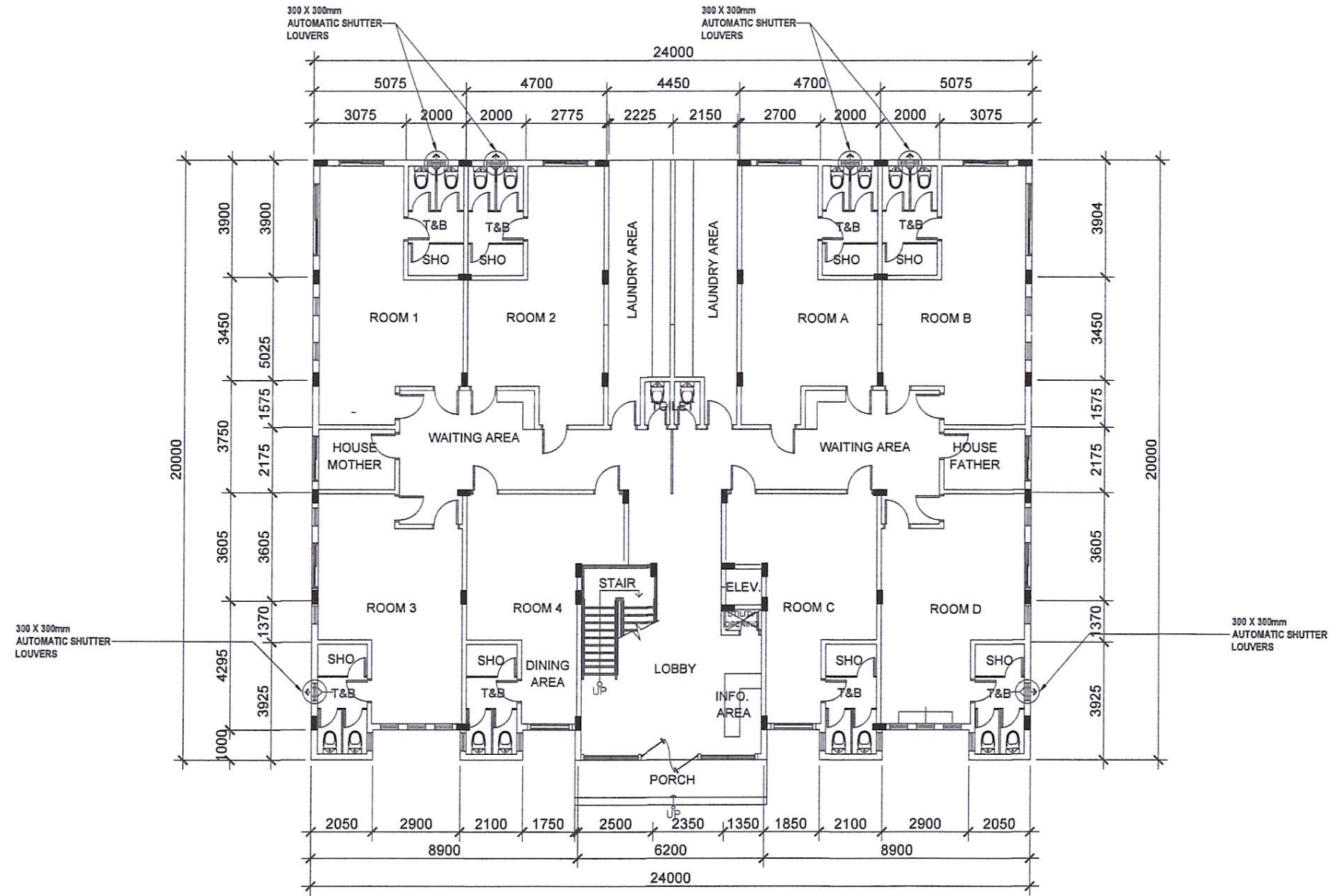

DORMITORY BUILDING
1 GROUND FLOOR VENTILATION AND AIRCONDITIONING LAYOUT
 M-2 SCALE 1:100 M

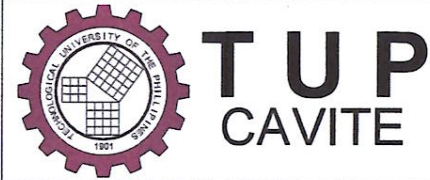

PROJECT TITLE:
PROPOSED TUPC DORMITORY

DESIGNED BY:
 ENGR. BRYLLE EPHRAIEM Q. NAVARRO
 IDO, CHAIRPERSON

APPROVED BY:
 ENGR. ALEXANDER E. MAG-ISA, Ph.D., PME
 CAMPUS DIRECTOR

DESIGNED BY:
 IDO - CAVITE
 CAD BY:

SHEET NO.
M 1

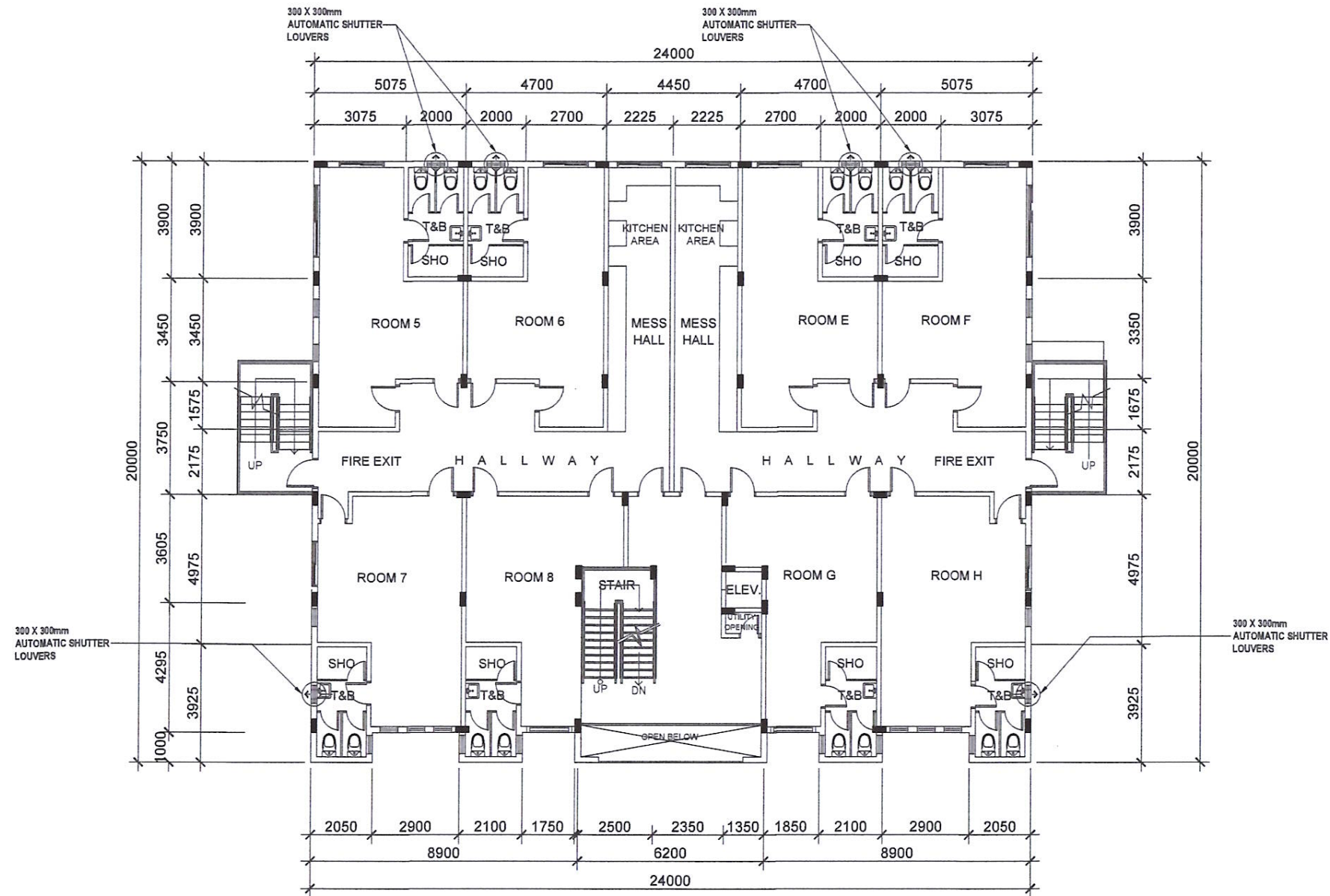

1
M-3

DORMITORY BUILDING
SECOND FLOOR VENTILATION AND AIRCONDITIONING LAYOUT
 SCALE 1:100 M

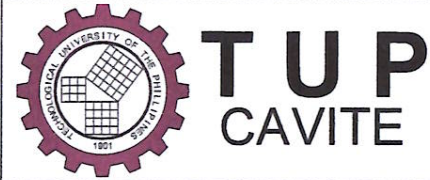

PROJECT TITLE:
**PROPOSED TUPC
 DORMITORY**

DESIGNED BY:
 ENGR. BRYLLE EPHRAIEM Q. NAVARRO
 IDO, CHAIRPERSON

APPROVED BY:
 ENGR. ALEXANDER E. MAG-ISA, Ph.D., PME
 CAMPUS DIRECTOR

DESIGNED BY:
 IDO - CAVITE
 CAD BY:

SHEET NO.
M 2

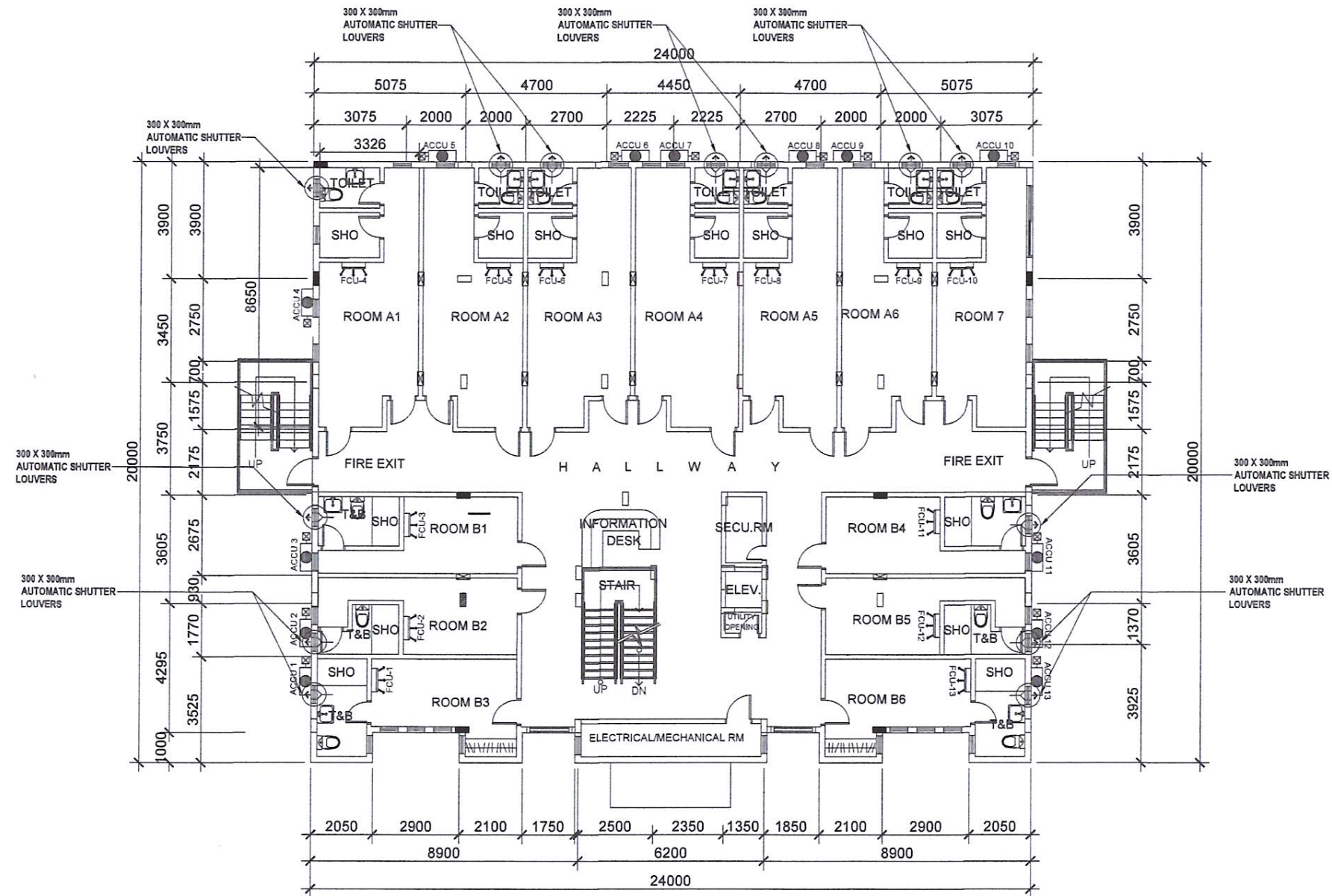

1
M-4
DORMITORY BUILDING
THIRD FLOOR VENTILATION AND AIRCONDITIONING LAYOUT
SCALE 1:100 M

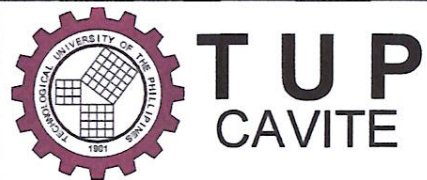

PROJECT TITLE:
**PROPOSED TUPC
DORMITORY**

DESIGNED BY:
[Signature]
ENGR. BRYLLE EPHRAIEM Q. NAVARRO
IDO, CHAIRPERSON

APPROVED BY:
[Signature]
ENGR. ALEXANDER E. MAG-ISA, Ph.D., PME
CAMPUS DIRECTOR

DESIGNED BY:
IDO - CAVITE
CAD BY:

SHEET NO.
M 3



TUPC DORMITORY DETAILED PLUMBING PLAN

GENERAL NOTES

-THE MECHANICAL DRAWINGS SHALL BE READ AS ONE UNIT INCLUDING PLANS, RISER DIAGRAMS AND OTHER DETAILS
 -MECHANICAL DRAWINGS SHALL BE READ WITH THE ARCHITECTURAL, STRUCTURAL, ELECTRICAL AND OTHER DRAWINGS FOR COORDINATION, VERIFICATION OF ADEQUATE SPACES AND EARLY DETERMINATION OF ANY CONTRADICTIONS OR INTERFERENCE PER THE PROVISIONS OF THE SPECIFICATION
 -THE DRAWINGS ARE ISSUED FOR MECHANICAL WORKS ONLY AND SHALL NOT BE USED FOR ARCHITECTURAL, STRUCTURAL OR OTHER WORKS
 -DRAWING IS NOT TO SCALE FOR THE EXECUTION OF WORK. ALL MEASUREMENTS SHALL BE MADE FROM ESTABLISHED LINES, LEVELS AND BENCH MARKS AS DETERMINED ON SITE WITH APPROVAL OF SUPERVISION ENGINEER
 -THE DRAWINGS ARE ONLY DIAGRAMMATIC, THE CONTRACTOR SHALL EXECUTE ALL WORK IN ACCORDANCE WITH APPROVED SHOP AND INSTALLATION DRAWINGS PER THE PROVISIONS OF THE SPECIFICATION
 -FOR EQUIPMENT CAPACITIES, RATINGS, TYPES AND CHARACTERISTICS REFER TO THE "SCHEDULE OF EQUIPMENT" DRAWINGS. BE READ IN CONJUNCTION WITH SPECIFICATION

-DRAINAGE PIPE CONNECTIONS:

UNLESS OTHERWISE INDICATED THE PIPE CONNECTION TO EACH SANITARY FIXTURE SHALL BE AS FOLLOWS:

SINK: 50MM
 FLOOR DRAIN: 75MM
 WATER CLOSET: 100MM
 SHOWER: 50MM

-ALL PIPE RUNS SHOWN ARE UNDER TILE UNLESS OTHERWISE STATED
 -MECHANICAL WORKS REQUIRING ELECTRICAL SERVICES SHALL BE COORDINATED WITH THE ELECTRICAL TRADE
 -PIPE MATERIAL WHEN NOT SHOWN ON DRAWINGS SHALL BE AS PER BILL OF QUANTITIES
 -ALL DIMENSIONS ARE IN mm UNLESS OTHERWISE STATED
 -ALL NOTES STATED ON THE DRAWING SHALL BE RESPECTED BY INSTALLER OR CONTRACTOR

PLUMBING NOTES

-INSTALLATION OF THE EQUIPMENT, PIPE AND FITTINGS UNDER SLABS SHALL BE EXECUTED IN FULL COORDINATION WITH THE ARCHITECTURAL, LANDSCAPE, STRUCTURAL, ELECTRICAL AND OTHER MECHANICAL DRAWINGS AND SCHEDULES
 -ALL MATERIALS AND METHODS OF INSTALLATION SHALL COMPLY FULLY WITH THE REQUIREMENT OF THE LATEST STANDARD AND SHALL BE CONSISTENT WITH AN INSTALLATION OF HIGHER QUALITY
 -ALL SUPPORTS AND HANGERS SHALL BE CONCEALED UNLESS OTHERWISE STATED, AND ACCORDANCE WITH MANUFACTURER'S RECOMMENDATION. ALL INSTALLATION SHALL BE ACCESSIBLE FOR MAINTENANCE. ENSURE THAT ACCESS DOORS ARE PROVIDED FOR EASY ACCESS TO CONCEALED DRAINS, VALVES AND CLEANOUTS.
 -PROVIDE ALL PIPE PENETRATIONS THROUGH WALL PARTITIONS AND SLABS WITH SLEEVE LARGE ENOUGH TO ACCOMMODATE THE PIPE PLUS ANY INSULATION AND THERMAL MOVEMENT. SLEEVE THROUGH INTERIOR WALLS AND PARTITIONS TO BE FLUSH WITH STANDARD SURFACES.
 -ALL UNDERGROUND WATER CONNECTION VALVES SHALL HAVE MILD STEEL VALVE BOXES IN ACCESSIBLE LOCATIONS TO FACILITATE EASY REMOVAL, FOR REPAIR OR REPLACEMENT
 -CAST IRON SINGLE SEAL COVERS WITH IDENTIFICATION MARKERS SHALL BE PROVIDED FOR ACCESS TO THE VALVES DURING USE AND REPAIRS

-ALL SANITARY FIXTURES WITHOUT INTEGRAL P-TRAPS SUCH AS SHOWER SHALL BE PROVIDED WITH APPROPRIATE P-TRAPS APPROVED BY THE SITE ENGINEER
 -THE WATER STORAGE TANKS SHALL INCLUDE FLOAT VALVE, FLOAT BALL, BELL MOUTH INLET AT PUMP SUCTION LINE, RELIEF VENTS, ACCESS LADDER OR CLIMBING RINGS, OVERFLOW PIPE, HIGH AND LOW CUT-OFF LEVEL SWITCHES, SIDE ACCESS WITH AIR TIGHT COVERS AND PROVISIONS FOR PIPE CONNECTIONS
 -THE MECHANICAL CONTRACTORS SHALL PROVIDE ELECTRICAL WIRING FOR MECHANICAL EQUIPMENT UP TO THE ISOLATORS PROVIDED BY THE ELECTRICAL CONTRACTOR. THE MECHANICAL CONTRACTOR SHALL BE RESPONSIBLE FOR THE MOTOR CONTROL CENTERS AND CONTROL PANEL OF HIS SUPPLIED EQUIPMENT.
 -POTABLE WATER SHALL BE PROVIDED FROM AN UNDER GROUND REINFORCED CONCRETE TANK CONNECTED TO A TRUCK-FILL POINT A CONNECTION LINE TO THE FUTURE MUNICIPALITY WATER MAIN, AND BE FILLED BY A CONNECTION FROM THE WATER NETWORK, SHALL BE PROVIDED.
 -COLD WATER PIPING INSIDE THE WET AREA SHALL BE UPVC CLASS (5)
 -HOT WATER PIPING INSIDE THE WET AREA SHALL BE CPVC SCH 80 WITH THERMAL INSULATION

PLUMBING NOTES

-WASTE STACKS, VENT PIPING AND DRAIN RUN IN GROUND SHALL BE UPVC CLASS-3. EXTERNAL SEWER PIPING BELOW GROUND-UNDER SLAB- SHALL BE UPVC CLASS-5.
 -VENT PIPE AND SOIL WASTE STACKS ON ROOF EXPOSED TO SUN JOINING AND FITTING SHALL BE EITHER SOLVENT WELD SOCKETS OR BY RING SEAL PUSH FIT FITTING AS RECOMMENDED BY THE PIPE MANUFACTURER
 -DRAINAGE MANHOLES SHALL REINFORCED CONCRETE WITH BLACK COATED CAST IRON MANHOLE COVERS AND FRAMES. THE MANHOLE COVERS SHALL HAVE APPROPRIATE IDENTIFICATION MARKER -ALL INTERNAL MANHOLE SURFACES SHALL BE COATED WITH TWO COATS OF APPROVED BITUMINOUS PAINT. ONE COAT OF SAME PAINT SHALL BE APPLIED TO EXTERNAL SURFACES. -SLOPES OF SOIL AND WASTE PIPES SHALL BE 1-2% OTHERWISE INDICATED ON THE LAYOUTS.
 -VENT PIPES THROUGH ROOF SHALL HAVE RIGID SUPPORTS AND BE MADE WATER TIGHT WITH THE ROOF BY PROPER FLASHING, WITH VENT COWL.
 -ALL DRAINAGE PIPE WORK SHALL BE TESTED IN ACCORDANCE WITH BS 5572 AND BS 8301.06. SANITARY FIXTURES SHALL BE AS SPECIFIED IN SPEC ALL PIPES SHALL GO THROUGH OF THE TOTAL BEAM LENGTH FROM COLUMN TO COLUMN.

HVAC NOTES

HV.A.C. CONTRACTOR SHALL COORDINATE WITH ALL TRADES BUT NOT LIMITED TO THE FOLLOWING:
 STRUCTURAL SUPPORTS FOR ROOF TOP MOUNTED CONDENSING UNITS, AND EXHAUST FANS
 A. OPENING IN WALLS, FLOOR, AND ROOF.
 B. ALL DIFFUSER AND REGISTER LOCATIONS.
 C. EQUIPMENT WEIGHTS WHEN SUSPENDED FROM CEILING OR MOUNTED ON ROOF. DRAIN FROM EQUIPMENT AT THE ROOF.
 D. ALL THERMOSTAT LOCATIONS.
 - ALL EQUIPMENT CAPACITY AND SPECIFICATION SHALL BE AS NOTED ON DRAWINGS.
 - ALL EQUIPMENT SHALL BE PROVIDED WITH VIBRATION ABSORBER,
 - THE CONTRACTOR SHALL BE COORDINATE THE AIR CONDITIONING EQUIPMENT, DUCT WORKS PIPING AND EXHAUST FANS WITH STRUCTURAL & ARCHITECTURAL DRAWINGS.
 - THE MECHANICAL CONTRACTOR MUST COORDINATE THE FINAL LOCATION OF THE OPENINGS THROUGH CEILINGS, FLOORS, WALLS & ROOF WITH ARCHITECTURAL, ELECTRICAL, AND STRUCTURAL SHOP DRAWINGS AND ENGINEERS.
 - COORDINATE ALL DIFFUSERS AND GRILLES LOCATIONS WITH REFLECTED CEILING PLANS, LIGHT FITTINGS, AND FALSE CEILING ACCESS PANELS.
 - CONTROL COMPONENTS SHOULD BE ACCESSIBLE.
 - ALL EQUIPMENT SHALL BE PROVIDED WITH STANDARD CONTROLS, INDICATORS AND ETC. NEEDED FOR THE EFFICIENT OPERATION OF AC SYSTEM. FCU ROOM THERMOSTAT SHOULD BE INSTALLED NEAR THE RETURN, EXACT LOCATION TO BE CO-ORDINATED WITH CIVIL, WORKS, PROVIDE NECESSARY FIRE DAMPER (DUCT PASSING THRU WALL OR CONCRETE FLOOR SLAB) AS REQUIRED
 - ALL CONTROL INSTRUMENTS AND MECHANICAL EQUIPMENT EXPOSED TO OUTSIDE WEATHER CONDITIONS SHALL BE WEATHER PROOF ACCORDING TO MANUFACTURER'S RECOMMENDATIONS.
 - ALL NEEDED SUPPORTS FOR EQUIPMENT MOUNTING ARE TO BE PROVIDED AND INSTALLED BY THE CONTRACTOR BASED ON OFFICE APPROVAL.
 - ALL STEEL MATERIALS USED FOR MOUNTING BASES SUPPORTS, BRACKETS AND ETC. SHALL BE PAINTED WITH DEPENDABLE PROTECTIVE COATING AGAINST RUST AND CORROSION.
 - ALL CONDENSATE DRAIN PIPE SHALL BE UPVC PIPE AND TAPPED TO THE NEAREST DRAINAGE SYSTEM WITH TUN DISH CONNECTION.
 - THE CONTRACTOR SHALL BE RESPONSIBLE TO ACHIEVE THE NOISE LEVEL LESS THAN 35 DPa
 - PROVIDE DOOR LOUVERS, GRILLS AND UNDERCUT WHERE REQUIRED.
 - THE MECHANICAL CONTRACTOR SHALL PROVIDE ELECTRICAL WIRING OF THE HVAC PLANT AND REMOTE SENSORS/DETECTORS UP TO THE ISOLATORS PROVIDED BY THE ELECTRICAL CONTRACTORS.
 - THE MECHANICAL CONTRACTOR SHALL BE RESPONSIBLE FOR THE MOTOR CONTROL, REMOTE SWITCH, STARTER ISOLATORS AND CONTROL PANELS.
 - THE CONTRACTOR WILL TURN OVER ALL MECHANICAL EQUIPMENT MANUALS AND INSTRUCTION, OVER TO THE USER AT THE COMPLETION OF CONS

DESIGN DATA FOR SEPTIC TANK

NO. OF USERS APPROX. 50
 PER CAPACITY CONSUMPTION OF WATER: 136 LPCD
 ASSUMING 70% OF WATER CONSUMPTION TRANSFORMED INTO SEWAGE, SEWAGE FLOW RATE: 94.5 LPCD
 PORTABLE PEAK DISCHARGE FOR 50 USERS: 108 LPM
 SURFACE AREA OF THE TANK REQUIRED FOR EVERY 10LPM OF PEAK FLOW AT A TEMP 25DEGC: 0.92 SQ.M.
 MINIMUM DEPTH OF SEDIMENTATION: 300MM
 PER CAPITA SUSPENDED SOLIDS ENTERING THE TANK: 70G/DAY PER CAPACITY REQUIRED FOR SLUDGE DIGESTION: 0.033CU.M PER CAPITA VOLUME OF DIGESTED SLUDGE: 0.00021Cu.M/DAY
 DETENTION TIME: 36HRS
 SEPTIC TANK CLEANING INTERVAL: 1 YEAR
 SEPTIC TANK CAPACITY
 TANK VOLUME: 7.0875CU.M
 SLUDGE STORAGE CAPACITY: 3.8325Cu.M
 TOTAL CAPACITY OF SEPTIC TANK: 10.92CU.M
 WITH THE PROVISION OF FUTURE EXPANSION, KEEPING 20% MARGIN, THE TOTAL CAPACITY: 14CU.M
 SEPTIC TANK SIZE
 ASSUME THE LIQUID DEPTH: 1.4M
 PLAN AREA OF THE TANK: 10M
 LENGTH TO WIDTH RATION: 2
 WIDTH OF THE TANK: 2.3M
 LENGTH OF THE TANK: 4.6M
 FREE BOARD: 0.4M
 CHECK FOR SURFACE AREA
 SURFACE AREA REQUIRED: 9.936SQ.M
 SURFACE AREA PROVIDED: 10.58SQ.M OK
 SLUDGE DEPTH REQUIRED: 0.23393195M
 SLUDGE DEPTH PROVIDED: 0.37 OK
 SIZE OF SEPTIC TANK 4.6M LX 2.3MW X 1.4M SWD + 0.4M F.B.



PROJECT TITLE: PROPOSED TUPC DORMITORY	DESIGNED BY:	DESIGNED BY:	SHEET NO.
	ENGR. BRYLLE EPHRAIEM Q. NAVARRO IDO, CHAIRPERSON	ENGR. ALEXANDER E. MAG-ISA, Ph.D., PME CAMPUS DIRECTOR	P 1
		DESIGNED BY: IDO - CAVITE	
		CAD BY:	

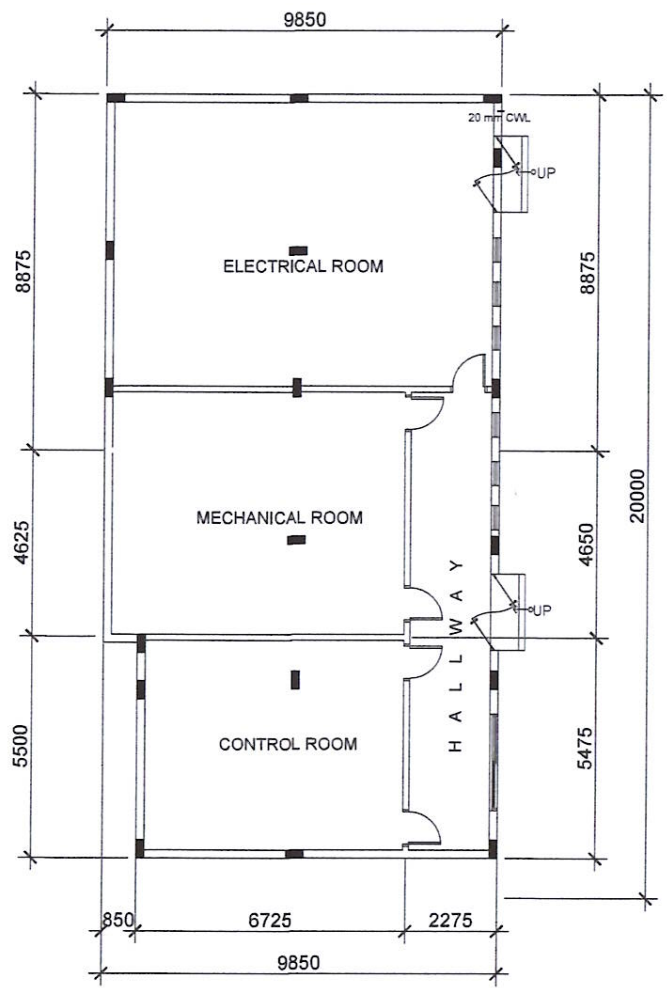

1 DORMITORY BUILDING
BASEMENT FLOOR WATER SUPPLY PLAN
 P-6 SCALE 1:100 M

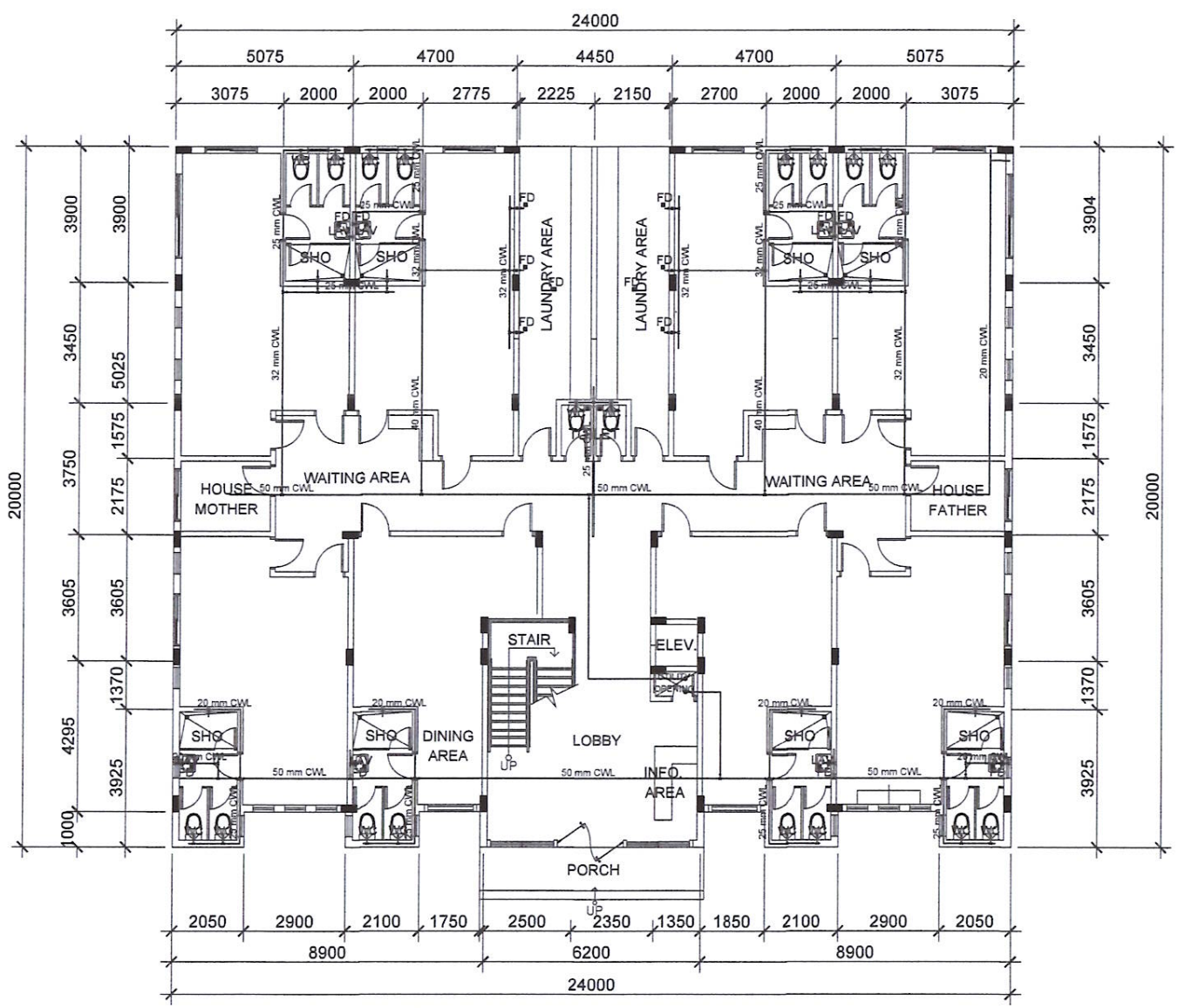

2 DORMITORY BUILDING
GROUND FLOOR WATER SUPPLY PLAN
 P-6 SCALE 1:100 M

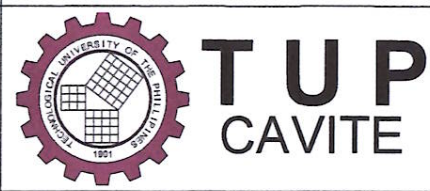

PROJECT TITLE:
PROPOSED TUPC DORMITORY

DESIGNED BY:
 ENGR. BRYLLE EPHRAIEM Q. NAVARRO
 IDO, CHAIRPERSON

APPROVED BY:
 ENGR. ALEXANDER E. MAG-ISA, Ph.D., PME
 CAMPUS DIRECTOR

DESIGNED BY:
 IDO - CAVITE
 CAD BY:

SHEET NO.
P 2

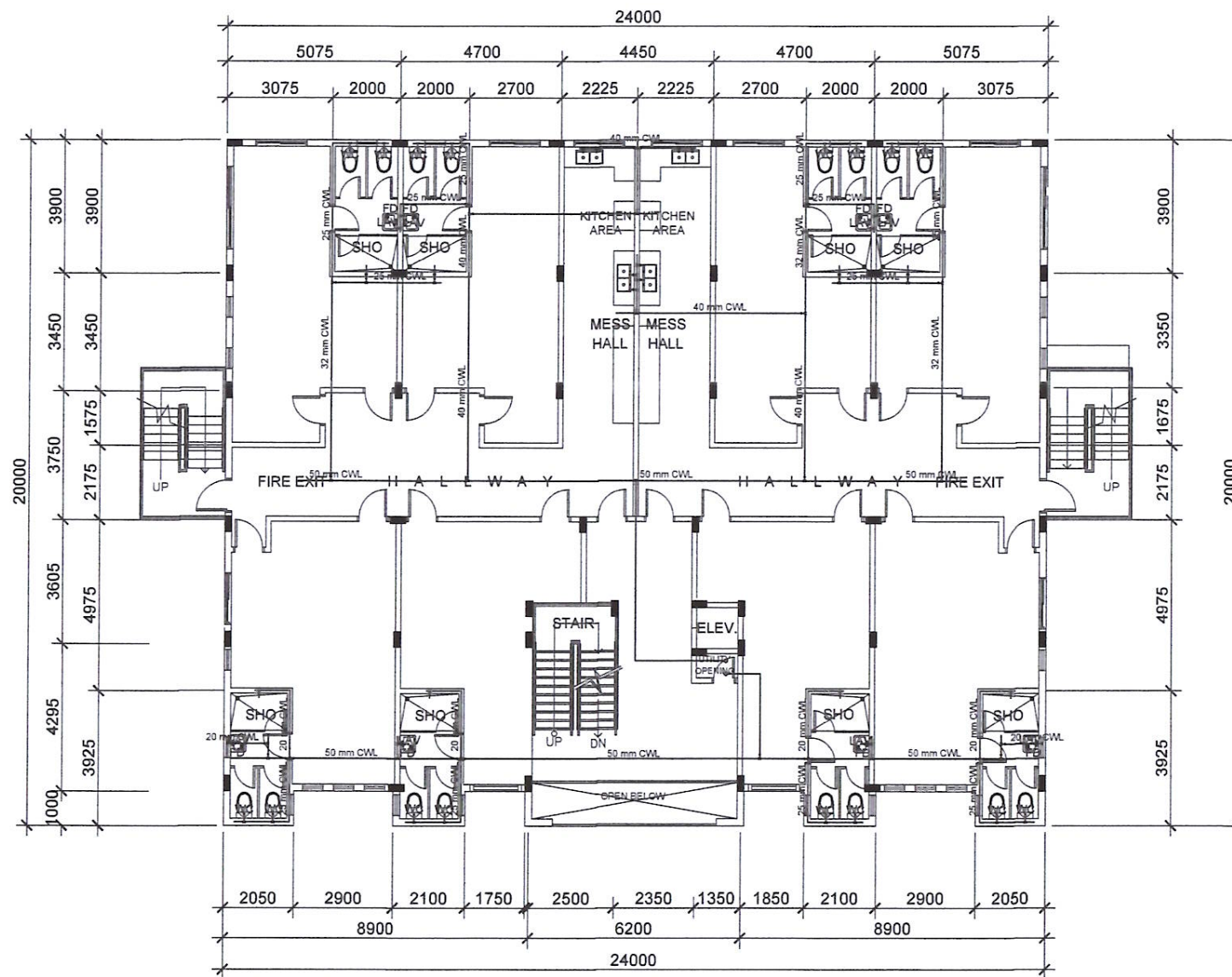

1
 DORMITORY BUILDING
SECOND FLOOR WATER SUPPLY PLAN
 SCALE 1:100 M

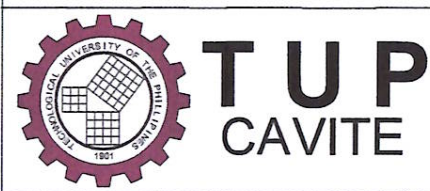

	PROJECT TITLE:	DESIGNED BY:	APPROVED BY:	DESIGNED BY:	SHEET NO.
	PROPOSED TUPC DORMITORY	ENGR. BRYLLE EPHRAIEM Q. NAVARRO IDO, CHAIRPERSON	ENGR. ALEXANDER E. MAG-ISA, Ph.D., PME CAMPUS DIRECTOR	IDO - CAVITE CAD BY:	<div style="border: 1px solid black; padding: 5px; display: inline-block;"> P 3 </div>

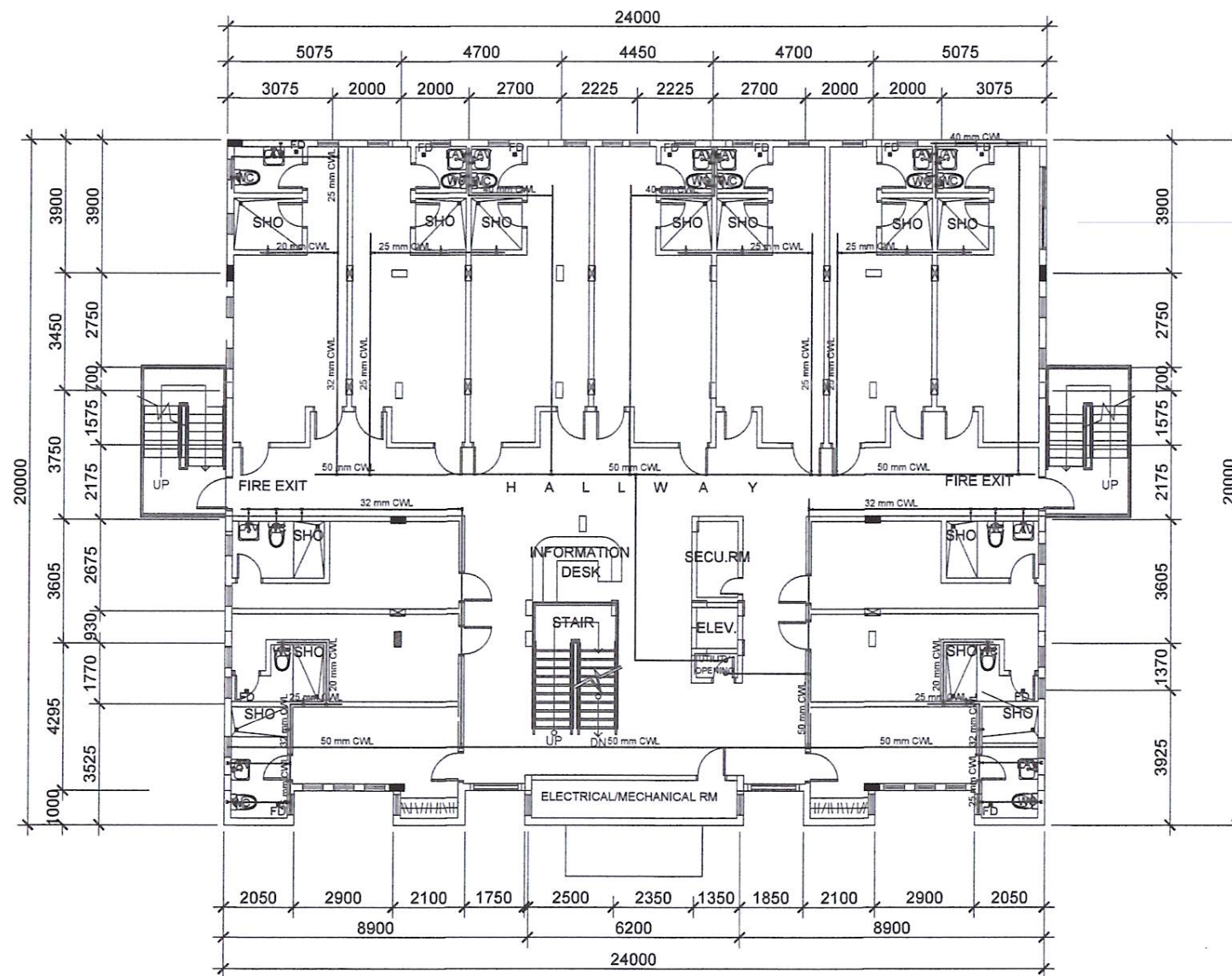

1
P-8

DORMITORY BUILDING
THIRD FLOOR WATER SUPPLY PLAN

SCALE 1:100 M

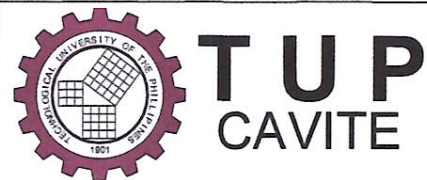

PROJECT TITLE:
**PROPOSED TUPC
DORMITORY**

DESIGNED BY:
[Signature]
ENGR. BRYLLE EPHRAIEM Q. NAVARRO
IDO, CHAIRPERSON

APPROVED BY:
[Signature]
ENGR. ALEXANDER E. MAG-ISA, Ph.D., PME
CAMPUS DIRECTOR

DESIGNED BY:
IDO - CAVITE
CAD BY:

SHEET NO.
P 4

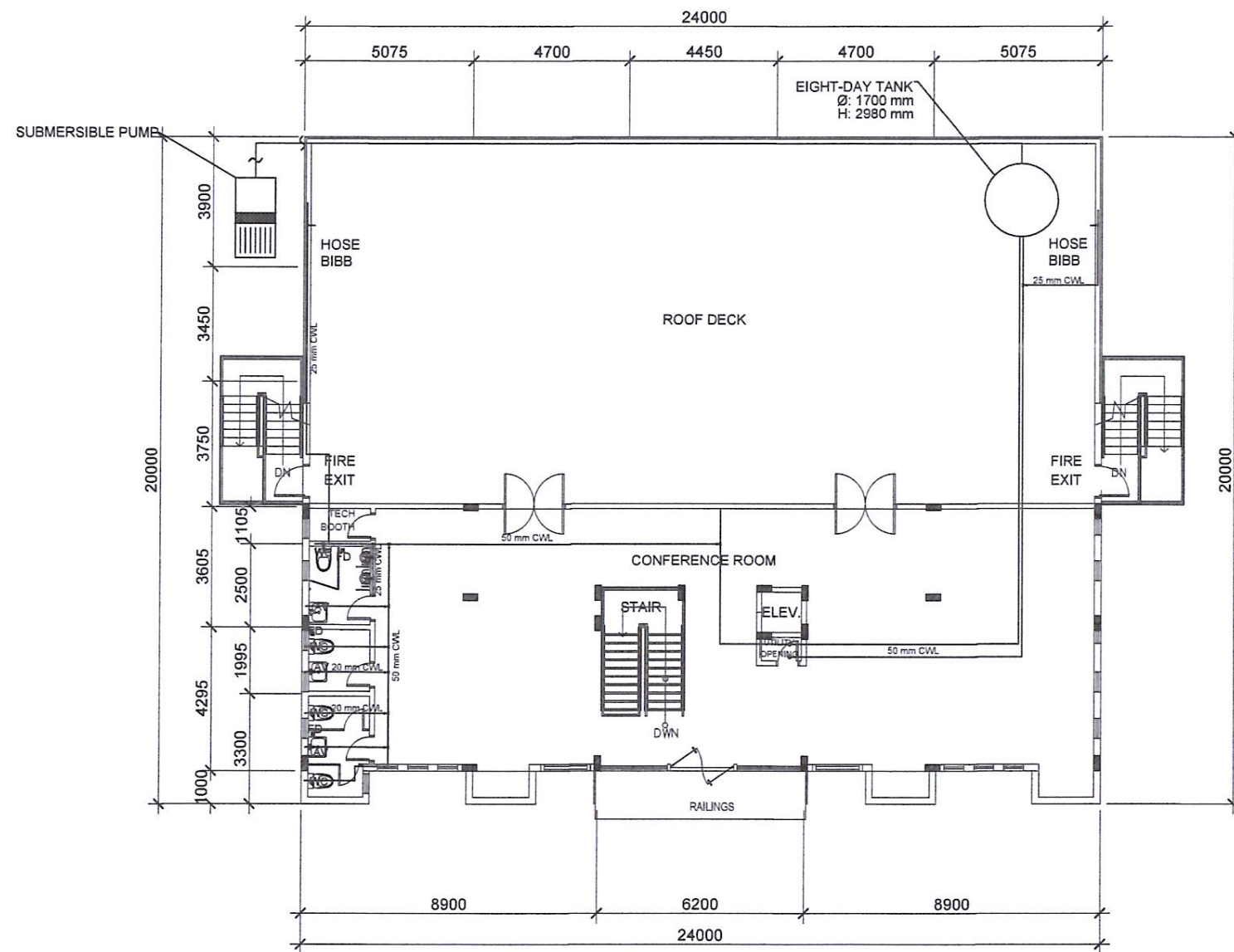

1
 DORMITORY BUILDING
FOURTH FLOOR WATER SUPPLY PLAN
 P-9 SCALE 1:100 M

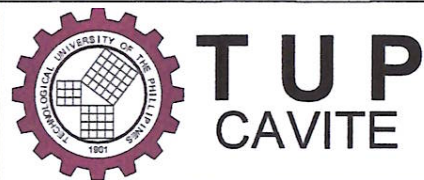

PROJECT TITLE:
**PROPOSED TUPC
 DORMITORY**

DESIGNED BY:
 AS SHOWN
ENGR. BRYLLE EPHRAIEM Q. NAVARRO
 IDO, CHAIRPERSON

APPROVED BY:
ENGR. ALEXANDER E. MAG-ISA, Ph.D., PME
 CAMPUS DIRECTOR

DESIGNED BY:
 IDO - CAVITE
 CAD BY:

SHEET NO.
P 5

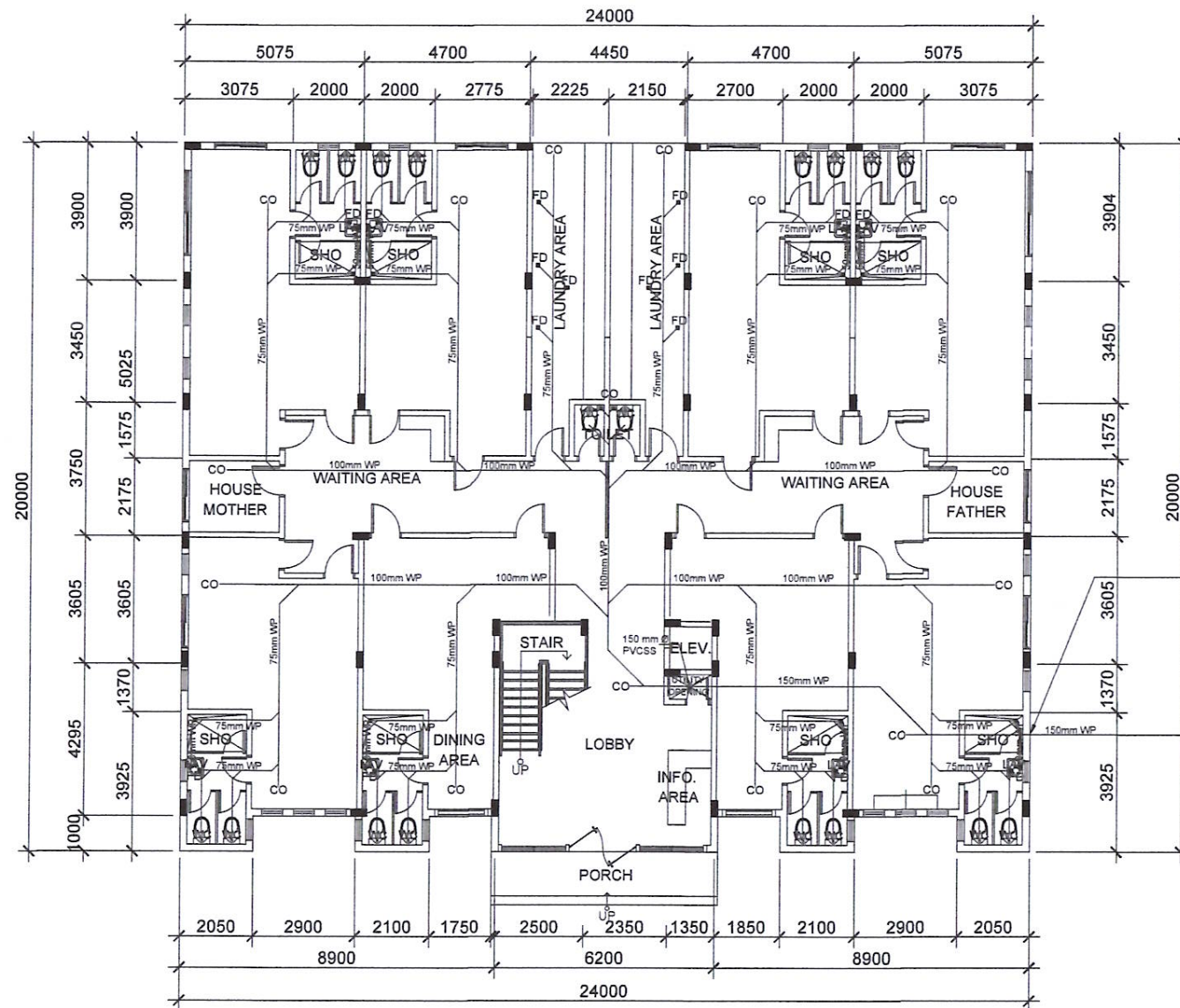

MAIN SEWER LINE DOES NOT PENETRATE THROUGH LESS THAN THE MINIMUM $\frac{1}{3}$ ALLOWANCE (1248.3333mm). MAIN SEWER LINE IS PLACED 1852.3224mm FROM ITS NEAREST COLUMN.

1
P-14
DORMITORY BUILDING
GROUND FLOOR WASTE WATER PLAN
SCALE 1:100 M

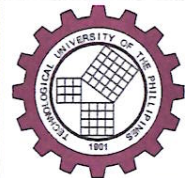

TUP
CAVITE

PROJECT TITLE:
PROPOSED TUPC DORMITORY

DESIGNED BY:
[Signature]
ENGR. BRYLLE EPHRAIEM Q. NAVARRO
AS SHOWN
IDO, CHAIRPERSON

APPROVED BY:
[Signature]
ENGR. ALEXANDER E. MAG-ISA, Ph.D., PME
CAMPUS DIRECTOR

DESIGNED BY:
IDO - CAVITE
CAD BY:

SHEET NO.
P 6

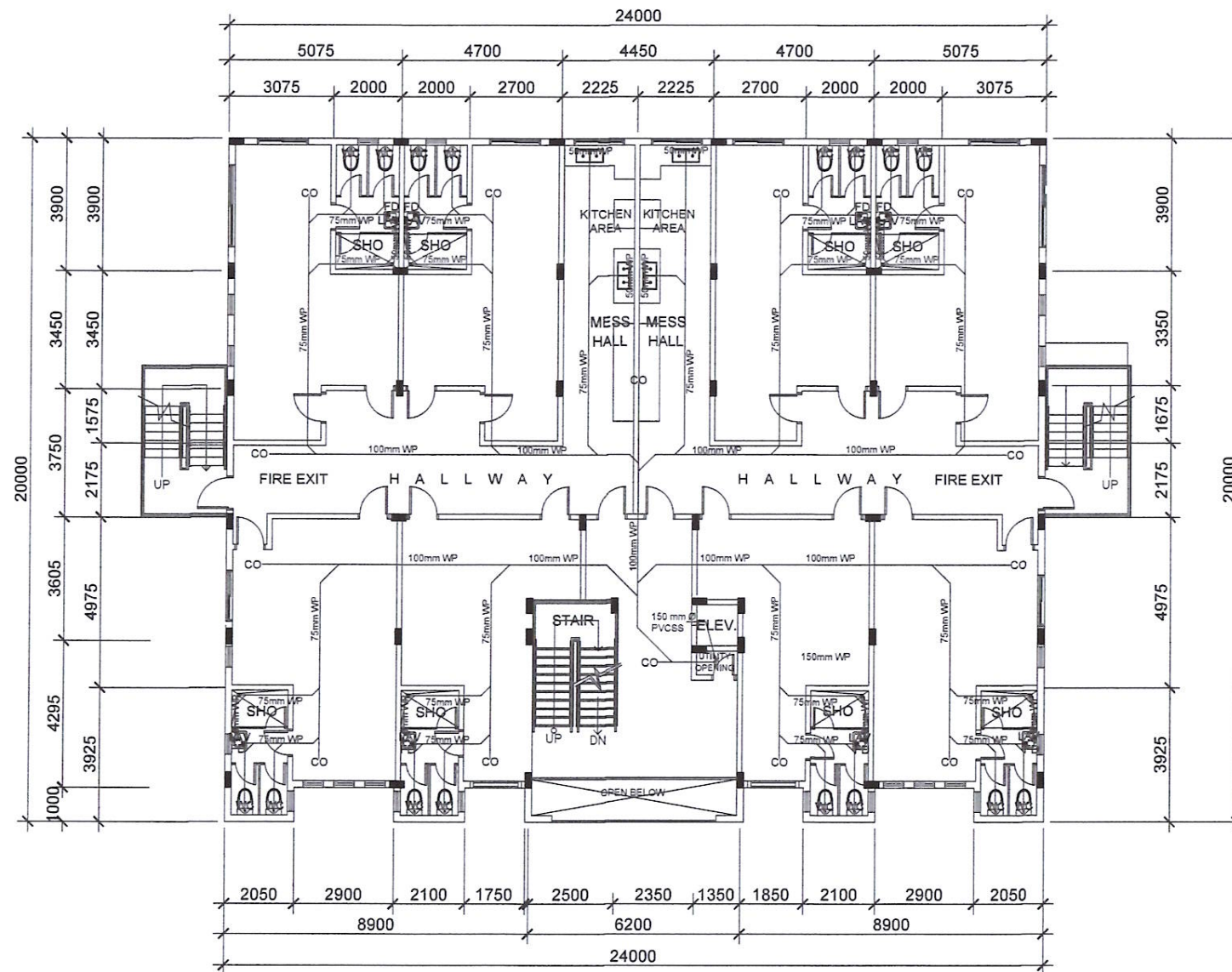

1 DORMITORY BUILDING
SECOND FLOOR WASTE WATER PLAN
 P-15 SCALE 1:100 M

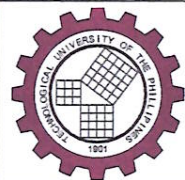

TUP
 CAVITE

PROJECT TITLE:
**PROPOSED TUPC
 DORMITORY**

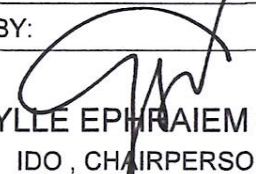
DESIGNED BY:

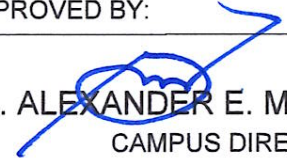
ENGR. BRYLLE EPHRAIEM Q. NAVARRO
 IDO, CHAIRPERSON

APPROVED BY:

ENGR. ALEXANDER E. MAG-ISA, Ph.D., PME
 CAMPUS DIRECTOR

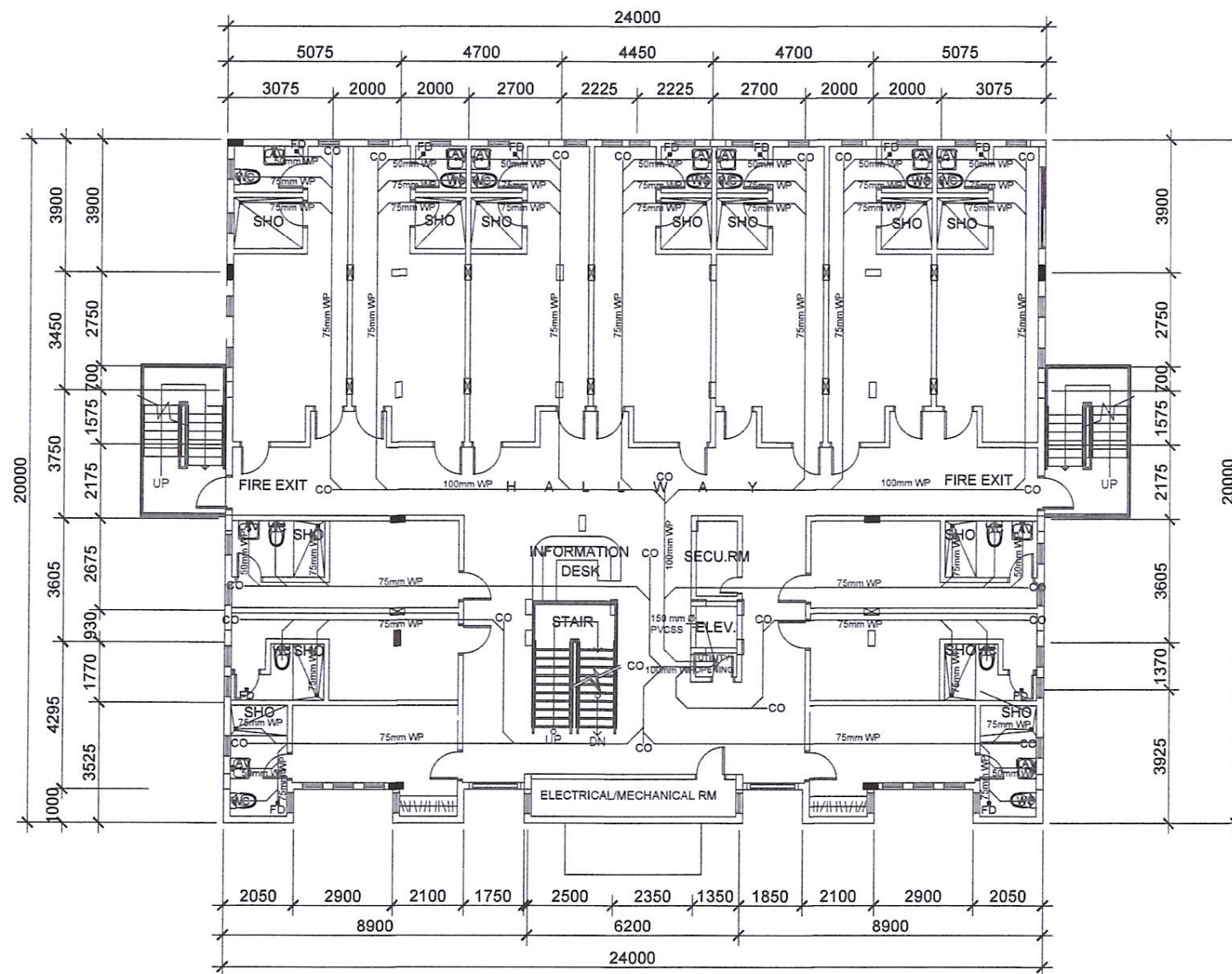
DESIGNED BY:
 IDO - CAVITE
 CAD BY:

SHEET NO.
P 7



1
P-16

DORMITORY BUILDING
THIRD FLOOR WASTE WATER PLAN

SCALE 1:100 M

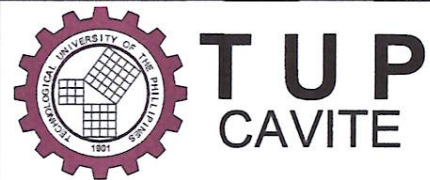

PROJECT TITLE:
**PROPOSED TUPC
DORMITORY**

DESIGNED BY:
[Signature]
ENGR. BRYLLE EPHRAIEM Q. NAVARRO
IDO, CHAIRPERSON

APPROVED BY:
[Signature]
ENGR. ALEXANDER E. MAG-ISA, Ph.D., PME
CAMPUS DIRECTOR

DESIGNED BY:
IDO - CAVITE
CAD BY:

SHEET NO.
P 8

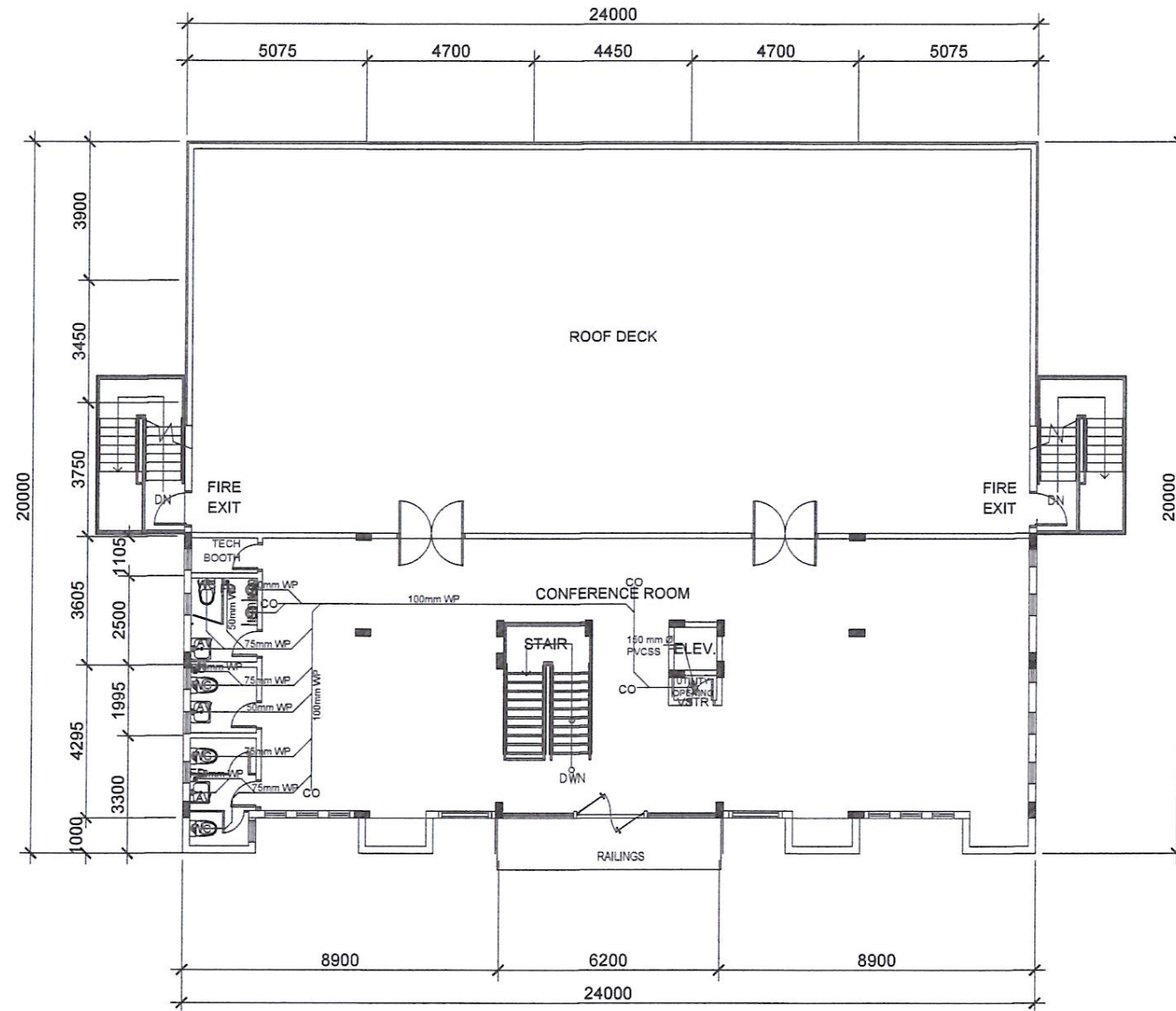

1
P-17

DORMITORY BUILDING
FOURTH FLOOR WASTE WATER PLAN

SCALE 1:100 M

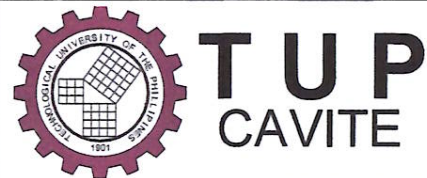

PROJECT TITLE:
**PROPOSED TUPC
DORMITORY**

DESIGNED BY:
[Signature]
ENGR. BRYLLE EPHRAIEM Q. NAVARRO
IDO, CHAIRPERSON

APPROVED BY:
[Signature]
ENGR. ALEXANDER E. MAG-ISA, Ph.D., PME
CAMPUS DIRECTOR

DESIGNED BY:
IDO - CAVITE
CAD BY:

SHEET NO.
P 9

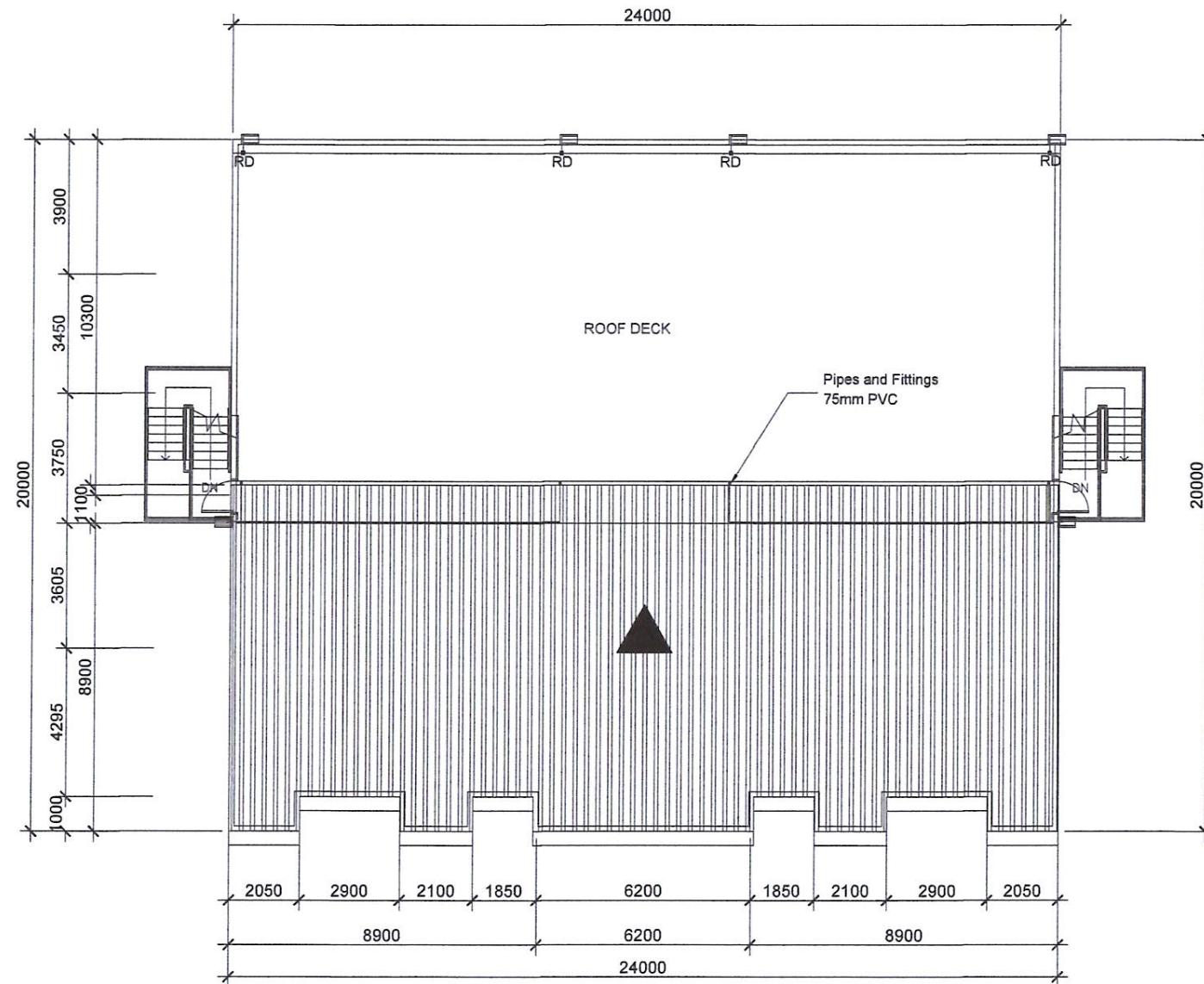

1
P-22

DORMITORY BUILDING
ROOF PLAN STORM DRAINAGE LAYOUT

SCALE 1:100 M

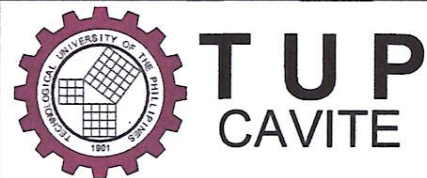

PROJECT TITLE:
PROPOSED TUPC DORMITORY

DESIGNED BY:
ENGR. BRYLLE EPHRAEM Q. NAVARRO
IDO, CHAIRPERSON

APPROVED BY:
ENGR. ALEXANDER E. MAG-ISA, Ph.D., PME
CAMPUS DIRECTOR

DESIGNED BY:
IDO - CAVITE
CAD BY:

SHEET NO.
P 10



TUPC DORMITORY PROGRAM OF WORK

**PROGRAM OF WORK FOR THE PROPOSED
TUPC DORMITORY - PHASE 2**

2.1m x 1.9m Glass Door Equal Swing Type	4	sets	
2.1m x 0.9m Glass Door Swing Type	4	sets	
2.1m x 0.9m Solid Flush Door	55	sets	
2.1m x 0.8m PVC Flush Door with Louver	40	sets	
2.1m x 0.6m Hollow Core Flush Door with Louver	6	sets	
2.1m x 1m Steel Door	6	sets	
4. PAINTING WORKS			
Supply and installation for Painting of trusses, ceiling including steel frames			
Painting of interior/exterior walls including doors and windows including the baseboard			
MATERIAL DESCRIPTION			
Skimcoat	935	lit	P
Primer	373	lit	
Putty (Spot)	373	lit	
Topcoat	683	lit	
Thinning Solvent for Putty	23	lit	
Thinning Solvent for Primer and Topcoat	134	lit	
Paint Brush	30	pcs	
Roller Brush	20	pcs	
4.1 WOOD PAINT			
Paint Enamel	232	lit	P
Quick Dry Enamel	386	lit	
Glazing Putty	371	lit	
Paint Thinner	199	lit	
4.2 STEEL PAINT			
Primer	26	lit	P
Top coat	42	lit	
Reducer for Primer	7	lit	
Reducer	10	lit	
5. SPECIALTY			
Supply and Installation of phenolic board partition and accessories at toilets			
MATERIAL DESCRIPTION			
12mmthk phenolic board for toilet and bath partition (includes doors and other accessories)	16	sets	P
6. CURTAIN WALL			
Aluminum framed with Reflective Glass Curtain Wall			
MATERIAL DESCRIPTION			
Glass Curtain Wall - (17.28 sq.m)	1	lot	P
7. CANOPY (GLASS)			
MATERIAL DESCRIPTION			
Canopy - (94.05 sq.m)	1	lot	P
8. ALUMINUM COMPOSITE PANELS			
MATERIAL DESCRIPTION			
Maroon Aluminum Composite Panel-(29.58 sq.m)	1	lot	P
9. WOOD COMPOSITE PLASTIC			
MATERIAL DESCRIPTION			
WPC - (Color: Dark Brown)- (117.2 sq.m)	1	lot	P

MATERIAL COST

LABOR COST

DIRECT COST

	QTY	UNIT	
III. PHASE 200 - STRUCTURAL			
SECOND LEVEL			
1. Reinforced Concrete Columns, Beams and Suspended Slabs (fc'= 30MPa Ready mix)			
1.1 Reinforced Concrete Slab			
a. Concrete	40.000	cu.m.	P
b. Reinforcing Steel Bars (12 mmØ)	1735	pcs.	
c. #16 G.I. Tie Wire	256	kg.	

**PROGRAM OF WORK FOR THE PROPOSED
TUPC DORMITORY - PHASE 2**

d. Formworks				
d.1 1.2mx2.4mx1/2" Plywood	36	pcs.		
d.3 2"x3"x12' Lumber	94	pcs.		
d.4 10d OR 3" CWN	27	kg.		
d.5 20d OR 4" CWN	56	kg.		
1.2 Reinforced Concrete Columns				
a. Concrete	16.400	cu.m.		P
b. Reinforcing Vertical Steel Bars (20 mmØ)	328	pcs.		
c. Lateral Ties (16 mmØ)	420	pcs.		
d. Formworks				
d.1 1.2mx2.4mx1/2" Plywood	26	pcs.		
d.2 2"x2"x10' Lumber	196	pcs.		
d.3 2"x3"x12' Lumber	67	pcs.		
d.4 10d OR 3" CWN	6	kg.		
d.5 20d OR 4" CWN	11	kg.		
e. #16 G.I. Tie Wire	73	kg.		
1.3 Reinforced Concrete Beams				
a. Concrete	34.700	cu.m.		P
b.0 Reinforcing Horizontal Steel Bars (12 mmØ)	10	pcs.		
b.1 Reinforcing Horizontal Steel Bars (16 mmØ)	226	pcs.		
b.2 Reinforcing Horizontal Steel Bars (20 mmØ)	245	pcs.		
c. Stirrups (10 mmØ)	445	pcs.		
d. Formworks				
d.1 1.2mx2.4mx1/2" Plywood	39	pcs.		P
d.2 2"x2"x10' Lumber	121	pcs.		
d.3 10d OR 3" CWN	8	kg.		
d.4 20d OR 4" CWN	16	kg.		
e. #16 G.I. Tie Wire	100	kg.		
1.4. Reinforced Concrete Stairs/Steps				
a. Concrete	3.000	cu.m.		P
b. Reinforcing Steel Bars (12 mmØ)	97	pcs.		
c. #16 G.I. Tie Wire	14	kg.		
d. Formworks				
d.1 1.2mx2.4mx1/2" Plywood	8	pcs.		
d.3 2"x3"x12' Lumber	12	pcs.		
d.4 10d OR 3" CWN	2	kg.		
THIRD LEVEL				
2. Reinforced Concrete Columns, Beams and Suspended Slabs (fc'= 30MPa Ready mix) including waterproofing				
2.1 Reinforced Concrete Slab				
a. Concrete	41.000	cu.m.		P
b. Reinforcing Steel Bars (12 mmØ)	1778	pcs.		
c. #16 G.I. Tie Wire	262	kg.		
d. Formworks				
d.1 1.2mx2.4mx1/2" Plywood	36	pcs.		
d.3 2"x3"x12' Lumber	96	pcs.		
d.4 10d OR 3" CWN	27	kg.		
d.5 20d OR 4" CWN	57	kg.		
2.2 Reinforced Concrete Columns				
a. Concrete	15.300	cu.m.		P
b. Reinforcing Vertical Steel Bars (20 mmØ)	306	pcs.		
c. Lateral Ties (16 mmØ)	392	pcs.		
d. Formworks				
d.1 1.2mx2.4mx1/2" Plywood	19	pcs.		
d.2 2"x2"x10' Lumber	182	pcs.		
d.3 2"x3"x12' Lumber	63	pcs.		
d.4 10d OR 3" CWN	5	kg.		
d.5 20d OR 4" CWN	10	kg.		
e. #16 G.I. Tie Wire	51	kg.		
2.3 Reinforced Concrete Beams				
a. Concrete	45.110	cu.m.		P
b.0 Reinforcing Horizontal Steel Bars (12 mmØ)	13	pcs.		
b.1 Reinforcing Horizontal Steel Bars (16 mmØ)	294	pcs.		
b.2 Reinforcing Horizontal Steel Bars (20 mmØ)	318	pcs.		
c. Stirrups (10 mmØ)	579	pcs.		
d. Formworks				
d.1 1.2mx2.4mx1/2" Plywood	40	pcs.		P
d.2 2"x2"x10' Lumber	158	pcs.		
d.3 10d OR 3" CWN	11	kg.		
d.4 20d OR 4" CWN	21	kg.		

**PROGRAM OF WORK FOR THE PROPOSED
TUPC DORMITORY - PHASE 2**

e. #16 G.I. Tie Wire	129	kg.	
2.4. Reinforced Concrete Stairs/Steps			
a. Concrete	3.000	cu.m.	P
b. Reinforcing Steel Bars (12 mmØ)	97	pcs.	
c. #16 G.I. Tie Wire	14	kg.	
d. Formworks			
d.1 1.2mx2.4mx1/2" Plywood	8	pcs.	
d.3 2"x3"x12' Lumber	15	pcs.	
d.4 10d OR 3" CWN	2	kg.	
ROOF DECK LEVEL			
3. Reinforced Concrete Columns, Beams and Suspended Slabs (fc'= 30MPa Ready mix)			
3.1 Reinforced Concrete Slab			
a. Concrete	41.000	cu.m.	P
b. Reinforcing Steel Bars (12 mmØ)	1778	pcs.	
c. #16 G.I. Tie Wire	262	kg.	
d. Formworks			
d.1 1.2mx2.4mx1/2" Plywood	28.8	pcs.	
d.3 2"x3"x12' Lumber	96	pcs.	
d.4 10d OR 3" CWN	27.2	kg.	
d.5 20d OR 4" CWN	56.8	kg.	
3.2 Reinforced Concrete Columns			
a. Concrete	8.350	cu.m.	P
b. Reinforcing Vertical Steel Bars (20 mmØ)	167	pcs.	
c. Lateral Ties (16 mmØ)	214	pcs.	
d. Formworks			
d.1 1.2mx2.4mx1/2" Plywood	11	pcs.	
d.2 2"x2"x10' Lumber	100	pcs.	
d.3 2"x3"x12' Lumber	34	pcs.	
d.4 10d OR 3" CWN	3	kg.	
d.5 20d OR 4" CWN	6	kg.	
e. #16 G.I. Tie Wire	28	kg.	
3.3 Reinforced Concrete Beams			
a. Concrete	38.170	cu.m.	P
b.0 Reinforcing Horizontal Steel Bars (12 mmØ)	11	pcs.	
b.1 Reinforcing Horizontal Steel Bars (16 mmØ)	249	pcs.	
b.2 Reinforcing Horizontal Steel Bars (20 mmØ)	269	pcs.	
c. Stirrups (10 mmØ)	490	pcs.	
d. Formworks			
d.1 1.2mx2.4mx1/2" Plywood	34	pcs.	P
d.2 2"x2"x10' Lumber	134	pcs.	
d.3 10d OR 3" CWN	9	kg.	
d.4 20d OR 4" CWN	18	kg.	
e. #16 G.I. Tie Wire	82	kg.	
3.4. Reinforced Concrete Stairs/Steps			
a. Concrete	2.760	cu.m.	P
b. Reinforcing Steel Bars (12 mmØ)	90	pcs.	
c. #16 G.I. Tie Wire	8	kg.	
d. Formworks			
d.1 1.2mx2.4mx1/2" Plywood	6	pcs.	
d.3 2"x3"x12' Lumber	12	pcs.	
d.4 10d OR 3" CWN	2	kg.	
ROOF LEVEL			
4. Reinforced Concrete Beams and Suspended Slabs (fc'= 30MPa Ready mix) including waterproofing			
4.1 Reinforced Concrete Slab			
a. Concrete	21.000	cu.m.	P
b. Reinforcing Steel Bars (12 mmØ)	1778	pcs.	
c. #16 G.I. Tie Wire	262.6	kg.	
d. Formworks			
d.1 1.2mx2.4mx1/2" Plywood	28.8	pcs.	
d.3 2"x3"x12' Lumber	96	pcs.	
d.4 10d OR 3" CWN	27.2	kg.	
d.5 20d OR 4" CWN	56.8	kg.	
4.2 Reinforced Concrete Beams			
a. Concrete	16.000	cu.m.	P
b. Reinforcing Horizontal Steel Bars (20 mmØ)	130	pcs.	
c. Stirrups (10 mmØ)	206	pcs.	
d. Formworks			
d.1 1.2mx2.4mx1/2" Plywood	18	pcs.	P
d.2 2"x2"x10' Lumber	70	pcs.	
d.3 10d OR 3" CWN	5	kg.	

**PROGRAM OF WORK FOR THE PROPOSED
TUPC DORMITORY - PHASE 2**

d.4 20d OR 4" CWN	10	kg.	
e. #16 G.I. Tie Wire	58	kg.	

MASONRY WORKS

1. SECOND LEVEL			
a. Mortar			
a.1 Cement (40 kg)	349	bags	P
a.2 Sand	29	cu.m.	
a.3 Gravel	3	cu.m.	
b. Reinforcing Steel Bars (10 mmØ)	498	pcs.	
c. #16 G.I. Tie Wire	18	kg.	
d. 150 mm CHB	2465	pcs.	
e. 100 mm CHB	4877	pcs.	
2. THIRD LEVEL			
a. Mortar			
a.1 Cement (40 kg)	457	bags	P
a.2 Sand	38	cu.m.	
a.3 Gravel	4	cu.m.	
b. Reinforcing Steel Bars (10 mmØ)	652	pcs.	
c. #16 G.I. Tie Wire	23	kg.	
d. 150 mm CHB	2948	pcs.	
e. 100 mm CHB	6703	pcs.	
3. ROOF DECK LEVEL			
a. Mortar			
a.1 Cement (40 kg)	119	bags	P
a.2 Sand	10	cu.m.	
a.3 Gravel	1	cu.m.	
b. Reinforcing Steel Bars (10 mmØ)	170	pcs.	
c. #16 G.I. Tie Wire	6	kg.	
d. 150 mm CHB	2460	pcs.	
e. 100 mm CHB	51	pcs.	

STEEL WORKS

1. FIRE EXIT			
a. Steel stair (as shown in plan)	2	lot	P

MATERIAL COST

LABOR COST

DIRECT COST

IV. PHASE 500 – MECHANICAL / HVAC / PLUMBING / FIRE PROTECTION / EQUIPMENT	QTY	UNIT	
Supply, installation and commissioning of all works under Phase500			
1. HVAC WORKS			
a. 1 HP SPLIT-TYPE AIR-CONDITIONING UNIT	13	set	
b. 3 HP SPLIT-TYPE AIR-CONDITIONING UNIT	4	set	
c. EXHAUST FANS	28	set	
d. 300×300mm AUTOMATIC SHUTTER LOUVER	28	set	
2.1 PLUMBING WORKS (ROUGH-IN)			
All materials required for the rough-in of Plumbing Works includes but not limited to the following:			
01. SECOND LEVEL			
1.1. Cold Water Line			
PPRC Pipe, 20mm × 4m, PN16	29	pc.	P
PPRC Pipe, 25mm × 4m, PN16	12	pc.	
PPRC Pipe, 32mm × 4m, PN16	5	pc.	
PPRC Pipe, 40mm × 4m, PN16	4	pc.	
PPRC Pipe, 50mm × 4m, PN16	9	pc.	
PP-R Elbow 20mm dia - 90 deg	40	pc.	
PP-R Elbow 25mm dia - 90 deg	14	pc.	
PP-R Elbow 50mm dia - 90 deg	2	pc.	
PP-R Tee 20mm dia	4	pc.	
PP-R Tee 25mm dia	4	pc.	
PP-R Tee 40mm dia	4	pc.	
PP-R Tee 50mm dia	4	pc.	
PP-R Cross 40mm dia	2	pc.	
PP-R Cross 50mm dia	4	pc.	

**PROGRAM OF WORK FOR THE PROPOSED
TUPC DORMITORY - PHASE 2**

PP-R Tee Reducer 25x20mm dia	28	pc.	
PP-R Tee Reducer 32x20mm dia	4	pc.	
PP-R Tee Reducer 40x20mm dia	8	pc.	
PP-R Tee Reducer 50x32mm dia	2	pc.	
PP-R Tee Reducer 50x40mm dia	2	pc.	
PP-R Coupling Reducer 32x25mm dia	3	pc.	
PP-R Coupling Reducer 40x25mm dia	1	pc.	
PP-R Coupling Reducer 40x32mm dia	1	pc.	
PP-R Coupling Reducer 50x20mm dia	4	pc.	
PP-R Coupling Reducer 50x25mm dia	8	pc.	
PVC End Cap 20mm dia	4	pc.	
PVC End Cap 25mm dia	16	pc.	
PVC End Cap 40mm dia	6	pc.	
PVC End Cap 50mm dia	4	pc.	
Pipe Hangers	55	pc.	
PVC Cement (1000 cc)	1	pc.	
PP-R Tee Reducer 50x40mm dia	2	pc.	
PP-R Coupling Reducer 32x25mm dia	4	pc.	
PP-R Coupling Reducer 40x32mm dia	2	pc.	
PP-R Coupling Reducer 50x20mm dia	4	pc.	
PP-R Coupling Reducer 50x25mm dia	8	pc.	
PVC End Cap 20mm dia	5	pc.	
PVC End Cap 25mm dia	19	pc.	
PVC End Cap 32mm dia	4	pc.	
PVC End Cap 50mm dia	4	pc.	
Pipe Hangers	58	pc.	
PVC Cement (1000 cc)	1	pc.	
02. THIRD FLOOR			
2.1. Cold Water Line			
PPRC Pipe, 20mm x 4m, PN16	33	pc.	
PPRC Pipe, 25mm x 4m, PN16	16	pc.	
PPRC Pipe, 32mm x 4m, PN16	13	pc.	
PPRC Pipe, 40mm x 4m, PN16	15	pc.	
PPRC Pipe, 50mm x 4m, PN16	24	pc.	
PP-R Elbow 20mm dia - 90 deg	43	pc.	
PP-R Elbow 25mm dia - 90 deg	1	pc.	
PP-R Elbow 32mm dia - 90 deg	2	pc.	
PP-R Elbow 40mm dia - 90 deg	3	pc.	
PP-R Elbow 50mm dia - 90 deg	1	pc.	
PP-R Tee 20mm dia	3	pc.	
PP-R Tee 25mm dia	4	pc.	
PP-R Tee 32mm dia	1	pc.	
PP-R Tee 40mm dia	3	pc.	
PP-R Tee 50mm dia	5	pc.	
PP-R Cross 50mm dia	2	pc.	
PP-R Tee Reducer 25x20mm dia	16	pc.	
PP-R Tee Reducer 32x20mm dia	9	pc.	
PP-R Tee Reducer 40x20mm dia	12	pc.	
PP-R Tee Reducer 50x25mm dia	3	pc.	
PP-R Tee Reducer 50x32mm dia	3	pc.	
PP-R Tee Reducer 50x40mm dia	3	pc.	
PP-R Coupling Reducer 32x25mm dia	3	pc.	
PP-R Coupling Reducer 50x25mm dia	2	pc.	
PP-R Coupling Reducer 50x32mm dia	2	pc.	
PVC End Cap 20mm dia	3	pc.	
PVC End Cap 25mm dia	12	pc.	
PVC End Cap 32mm dia	2	pc.	
PVC End Cap 40mm dia	6	pc.	
PVC End Cap 50mm dia	5	pc.	
Pipe Hangers	127	pc.	
PVC Cement (1000 cc)	1	pc.	
2.2. Waste Water Line			
Pipes and Fittings 50mm dia. x 3m PVC, Series 1000	18	pc.	
Pipes and Fittings 75mm dia. x 3m PVC, Series 1000	76	pc.	
Pipes and Fittings 100mm dia. x 3m PVC, Series 1000	13	pc.	
Pipes and Fittings 150mm dia. x 3m PVC, Series 1000	2	pc.	
Pipe Gasket 100mm x 75mm	13	pc.	
PVC P-trap W/Plug & Sealing Ring (50mm)	20	pc.	
PVC P-trap W/Plug & Sealing Ring (75mm)	13	pc.	
PVC 87.5deg (50mm BEND x 50mm)	22	pc.	
PVC 87.5deg (50mm BEND x 76mm)	13	pc.	
PVC 45deg (100mm BEND x 50mm)	22	pc.	

**PROGRAM OF WORK FOR THE PROPOSED
TUPC DORMITORY - PHASE 2**

PVC 45deg (100mm BEND × 76mm)	46	pc.	
PVC 45deg (100mm BEND × 101mm)	6	pc.	
PVC 45deg. Single branch, wye (50mm × 50mm)	5	pc.	
PVC 45deg. Single branch, wye (76mm × 50mm)	15	pc.	
PVC 45deg. Single branch, wye (76mm × 76mm)	27	pc.	
PVC 45deg. Single branch, wye (101mm × 76mm)	13	pc.	
PVC 45deg. Single branch, wye (101mm × 101mm)	4	pc.	
PVC Clean-Out W/Plug and Sealing Ring (76mm)	14	pc.	
PVC Clean-Out W/Plug and Sealing Ring (100mm)	6	pc.	
Pipe Hangers	175	pc.	
PVC Cement (1000cc)	1	pc.	
03 ROOF DECK FLOOR			
3.1. Cold Water Line			
PPRC Pipe, 20mm × 4m, PN16	13	pc.	
PPRC Pipe, 25mm × 4m, PN16	7	pc.	
PPRC Pipe, 50mm × 4m, PN16	25	pc.	
PP-R Elbow 20mm dia - 90 deg	18	pc.	
PP-R Elbow 25mm dia - 90 deg	7	pc.	
PP-R Elbow 50mm dia - 90 deg	3	pc.	
PP-R Tee 25mm dia	2	pc.	
PP-R Tee 50mm dia	2	pc.	
PP-R Tee Reducer 25×20mm dia	2	pc.	
PP-R Tee Reducer 50×20mm dia	5	pc.	
PP-R Tee Reducer 50×25mm dia	2	pc.	
PP-R Tee Reducer 50×32mm dia	1	pc.	
PVC End Cap 25mm dia	2	pc.	
PVC End Cap 50mm dia	1	pc.	
Pipe Hangers	61	pc.	
PVC Cement (1000 cc)	1	pc.	
3.2. Waste Water Line			
Pipes and Fittings 50mm dia. × 3m PVC, Series 1000	8	pc.	
Pipes and Fittings 75mm dia. × 3m PVC, Series 1000	8	pc.	
Pipes and Fittings 100mm dia. × 3m PVC, Series 1000	8	pc.	
Pipes and Fittings 150mm dia. × 3m PVC, Series 1000	2	pc.	
Pipe Gasket 100mm × 75mm	4	pc.	
PVC P-trap W/Plug & Sealing Ring (50mm)	8	pc.	
PVC 87.5deg (50mm BEND × 50mm)	10	pc.	
PVC 87.5deg (50mm BEND × 76mm)	4	pc.	
PVC 45deg (100mm BEND × 50mm)	7	pc.	
PVC 45deg (100mm BEND × 76mm)	9	pc.	
PVC 45deg (100mm BEND × 101mm)	3	pc.	
PVC 45deg. Single branch, wye (50mm × 50mm)	1	pc.	
PVC 45deg. Single branch, wye (76mm × 50mm)	3	pc.	
PVC 45deg. Single branch, wye (76mm × 76mm)	1	pc.	
PVC 45deg. Single branch, wye (101mm × 50mm)	3	pc.	
PVC 45deg. Single branch, wye (101mm × 76mm)	4	pc.	
PVC 45deg. Single branch, wye (101mm × 101mm)	3	pc.	
PVC Clean-Out W/Plug and Sealing Ring (76mm)	4	pc.	
Pipe Hangers	37	pc.	
PVC Cement (1000cc)	1	pc.	
2.2 PLUMBING FIXTURE			
Delivery and Supply of labor & materials and installation:			
1. WATER CLOSET-COMplete SET WITH FITTINGS	17	SET	
2. XC SOURCE HANDHELD TOILET BIDET, SHATTAF DOUCHE	17	SET	
3. URINAL-INCLUDING FITTINGS AND ACCESSORIES	2	SET	
4. LAVATORY INCLUDING FITTINGS AND ACCESSORIES	14	SET	
5. SOAP HOLDER	13	SET	
6. PAPER HOLDER	17	SET	
7. FLOOR DRAIN WITH STRAINER	31	SET	
8. ROOF DRAIN WITH STRAINER	4	SET	
9. FAUCET, HOSE BIBB	2	SET	
10. SHOWER HEAD	13	SET	
11. KITCHEN SINK INCLUDING FITTINGS AND ACCESSORIES	4	SET	
3. FIRE PROTECTION (FDAS)			
Includes design, plans (with signed and sealed) and installation including equipment, controls, programing and commissioning.			
	1	lot	
4. EQUIPMENT			

**PROGRAM OF WORK FOR THE PROPOSED
TUPC DORMITORY - PHASE 2**

8hp Booter water pump and accessories	1	set	
5. ELEVATOR			
Supply and installation of elevator	1	lot	

MATERIAL COST

LABOR COST

DIRECT COST

V. PHASE 700 - ELECTRICAL

PLUMBING WORKS (ROUGH-IN)			
All materials required for the rough-in of Plumbing Works includes but not limited to the following:			
SECOND FLOOR			
1. Switchboards - Panel boards and breakers			
PANEL BOARD 19-24 BRANCHES 225AMPS (ALF3242MB)	1.00	PCS	
2. PBX Boxes			
PBX BOX JUNCTION BOX (RJB1)	79.00	PCS	
PBX BOX UTILITY BOX (RUB1)	97.00	PCS	
3. Conduits			
INTERMEDIATE PVC CONDUIT PIPE 1/2" WITH AMERICAN THREAD	20.00	PCS	
INTERMEDIATE PVC CONDUIT ELBOW 1/2" WITH AMERICAN THREAD	20.00	PCS	
INTERMEDIATE PVC CONDUIT COUPLING 1/2" WITH AMERICAN THREAD	20.00	PCS	
INTERMEDIATE PVC CONDUIT LOCKOUT 1/2" WITH AMERICAN THREAD	20.00	PCS	
INTERMEDIATE PVC CONDUIT BUSHING 1/2" WITH AMERICAN THREAD	20.00	PCS	
INTERMEDIATE PVC CONDUIT L&B 1/2" WITH AMERICAN THREAD	20.00	PCS	
THIRD FLOOR			
10W LED FLUORESCENT LAMP 36 x 585 WARM WHITE (EBTST5WW10)	20.00	PCS	
12W LED DOWNLIGHT Ø165 x 35 WARM WHITE (EDL213612WW)	22.00	PCS	
6W LED A-BULBS 60 x 110 WARM WHITE FIREFLY (FBI206WW)	42.00	PCS	
OMNI LED SWIVEL HEAD AUTOMATIC EMERGENCY LIGHT (AEL-390)	15.00	PCS	
ALPHALUX WINSLETH CLASSIC CHANDELIER (8xe27)	1.00	PCS	
FIREFLY SINGLE-FACED EXIT LIGHT WITH WALL (FEL221A)	2.00	PCS	
3 GANG SWITCH ROYU ELECTRICAL CLASSIC SERIES (WH505)	15.00	PCS	
2 GANG SWITCH ROYU ELECTRICAL CLASSIC SERIES (WH503)	20.00	PCS	
1 GANG SWITCH ROYU ELECTRICAL CLASSIC SERIES (2H501)	20.00	PCS	
ROYU SUPER WIDE 1 GANG AIR CONDITIONING UNIT OUTLET SET (WS901)	15.00	PCS	
ROYU WIDE SERIES GFCI OUTLET 2 GANG (2D932)	26.00	PCS	
ROYU 3 GANG OUTLET SET CLASSIC SERIES (WH115)	50.00	PCS	
ROYU 2 GANG OUTLET SET CLASSIC SERIES (WHJ113)	25.00	PCS	
ROYU PBX BOX JUNCTION BOX (RJB1)	90.00	PCS	
ROYU PBX BOX UTILITY BOX (RUB1)	140.00	PCS	
GENERAL ELECTRIC PANEL BOARD 37-42 BRANCHES 225AMPS (ALF3422MB)	1.00	PCS	
SCHNEIDER 3 POLE MOULDED CASE CIRCUIT BREAKER 15AT/100AF	6.00	PCS	
SCHNEIDER 3 POLE MOULDED CASE CIRCUIT BREAKER 30AT/100AF	20.00	PCS	
SCHNEIDER 3 POLE MOULDED CASE CIRCUIT BREAKER 20AT/100AF	16.00	PCS	
ROYU THWN-2 STRANDED 14AWG	16.00	PCS	
ROYU THWN-2 STRANDED 12AWG	16.00	PCS	
INTERMEDIATE METAL CONDUIT PIPE 1/2" WITH AMERICAN THREAD	42.00		
INTERMEDIATE METAL CONDUIT ELBOW 1/2" WITH AMERICAN THREAD	42.00		

**PROGRAM OF WORK FOR THE PROPOSED
TUPC DORMITORY - PHASE 2**

INTERMEDIATE METAL CONDUIT COUPLING 1/2" WITH AMERICAN THREAD	42.00		
INTERMEDIATE METAL CONDUIT LOCKOUT 1/2" WITH AMERICAN THREAD	42.00		
INTERMEDIATE METAL CONDUIT BUSHING 1/2" WITH AMERICAN THREAD	42.00		
SUPER WIDE 1 GANG AIR CONDITIONING UNIT OUTLET SET (WS901)	13.00		
INTERMEDIATE METAL CONDUIT L&B 1/2" WITH AMERICAN THREAD	42.00		
FOURTH FLOOR			
12W LED DOWNLIGHT Ø165 x 35 WARM WHITE (EDL213612WW)	37.00		
6W LED A-BULBS 60 x 110 WARM WHITE FIREFLY (FBI206WW)	4.00		
OMNI LED SWIVEL HEAD AUTOMATIC EMERGENCY LIGHT (AEL-390)	2.00		
ALPHALUX WALL LAMP SERIES (1xe27 lp44)	17.00		
SINGLE-FACED EXIT LIGHT WITH WALL / (FEL221A)	2.00		
3 GANG SWITCH ROYU ELECTRICAL CLASSIC SERIES (WH505)	3.00		
2 GANG SWITCH ROYU ELECTRICAL CLASSIC SERIES (WH503)	2.00		
1 GANG SWITCH ROYU ELECTRICAL CLASSIC SERIES (2H501)	6.00		
SUPER WIDE 1 GANG AIR CONDITIONING UNIT OUTLET SET (WS901)	4.00		
ROYU WIDE SERIES GFCI OUTLET 2 GANG (2D932)	2.00		
ROYU 3 GANG OUTLET SET CLASSIC SERIES (WH115)	10.00		
ROYU 2 GANG OUTLET SET CLASSIC SERIES (WHJ113)	2.00		
ROYU PBX BOX JUNCTION BOX (RJB1)	43.00		
ROYU PBX BOX UTILITY BOX (RUB1)	29.00		
PANEL BOARD 13-18 BRANCHES 225AMPS (ALF1182AB)	1.00		
3 POLE MOULDED CASE CIRCUIT BREAKER 15AT/100AF	5.00		
3 POLE MOULDED CASE CIRCUIT BREAKER 30AT/100AF	3.00		
3 POLE MOULDED CASE CIRCUIT BREAKER 20AT/100AF	2.00		
3 POLE MOULDED CASE CIRCUIT BREAKER 50AT/100AF	4.00		
THWN-2 STRANDED RESISTANT 14AWG	30.00		
THWN-2 STRANDED RESISTANT 12AWG	30.00		
INTERMEDIATE METAL CONDUIT PIPE 1" WITH AMERICAN THREAD	4.00		
INTERMEDIATE METAL CONDUIT PIPE 1/2" WITH AMERICAN THREAD	10.00		
INTERMEDIATE METAL CONDUIT ELBOW 1" WITH AMERICAN THREAD	4.00		
INTERMEDIATE METAL CONDUIT ELBOW 1/2" WITH AMERICAN THREAD	10.00		
INTERMEDIATE METAL CONDUIT COUPLING 1"	4.00		
INTERMEDIATE METAL CONDUIT COUPLING 1/2"	10.00		
INTERMEDIATE METAL CONDUIT LOCKOUT 1" WITH AMERICAN THREAD	4.00		
INTERMEDIATE METAL CONDUIT LOCKOUT 1/2"	10.00		
INTERMEDIATE METAL CONDUIT BUSHING 1" WITH AMERICAN THREAD	4.00		
INTERMEDIATE METAL CONDUIT BUSHING 1/2"	10.00		
INTERMEDIATE METAL CONDUIT L&B 1" WITH AMERICAN THREAD	4.00		
INTERMEDIATE METAL CONDUIT L&B 1/2" WITH AMERICAN THREAD	10.00		
3 POLE MOULDED CASE CIRCUIT BREAKER 20AT/100AF	1.00		
3 POLE MOULDED CASE CIRCUIT BREAKER 200AT/225AF	1.00		
PANEL BOARD 0-12 BRANCHES 400AMPS (ALF1124CB)	1.00		
THWN-2 STRANDED RESISTANT 12AWG	3.00		
THWN-2 STRANDED RESISTANT 4/0AWG	3.00		
INTERMEDIATE METAL CONDUIT PIPE 1/2" WITH AMERICAN THREAD	1.00		

**PROGRAM OF WORK FOR THE PROPOSED
TUPC DORMITORY - PHASE 2**

INTERMEDIATE METAL CONDUIT PIPE 1.5" WITH AMERICAN THREAD	1.00		
INTERMEDIATE METAL CONDUIT ELBOW 1/2" WITH AMERICAN THREAD	1.00		
INTERMEDIATE METAL CONDUIT ELBOW 1.5" WITH AMERICAN THREAD	1.00		
INTERMEDIATE METAL CONDUIT COUPLING 1/2"	1.00		
INTERMEDIATE METAL CONDUIT COUPLING 1.5"	1.00		
INTERMEDIATE METAL CONDUIT LOCKOUT 1/2"	1.00		
INTERMEDIATE METAL CONDUIT LOCKOUT 1.5"	1.00		
INTERMEDIATE METAL CONDUIT BUSHING 1/2"	1.00		
INTERMEDIATE METAL CONDUIT BUSHING 1.5"	1.00		
INTERMEDIATE METAL CONDUIT L&B 1/2" WITH AMERICAN THREAD	1.00		
INTERMEDIATE METAL CONDUIT L&B 1.5" WITH AMERICAN THREAD	1.00		
MDP			
GENERAL ELECTRIC PANEL BOARD 0-12 BRANCHES 400AMPS (ALF1124JB)	1.00		
3 POLE MOULDED CASE CIRCUIT BREAKER 200AT/225AF	1.00		
3 POLE MOULDED CASE CIRCUIT BREAKER 125AT/250AF	2.00		
3 POLE MOULDED CASE CIRCUIT BREAKER 160AT/250AF	2.00		
3 POLE MOULDED CASE CIRCUIT BREAKER 225AT/250AF	2.00		
THWN-2 STRANDED 4/0AWG	1.00		
THWN-2 STRANDED 3/0AWG	1.00		
THWN-2 STRANDED 2/0AWG	4.00		
INTERMEDIATE METAL CONDUIT PIPE 1" WITH AMERICAN THREAD	5.00		
INTERMEDIATE METAL CONDUIT PIPE 2" WITH AMERICAN THREAD	1.00		
INTERMEDIATE METAL CONDUIT ELBOW 1" WITH AMERICAN THREAD	5.00		
INTERMEDIATE METAL CONDUIT ELBOW 2" WITH AMERICAN THREAD	1.00		
INTERMEDIATE METAL CONDUIT COUPLING 1"	5.00		
INTERMEDIATE METAL CONDUIT COUPLING 2"	1.00		
INTERMEDIATE METAL CONDUIT LOCKOUT 1" WITH AMERICAN THREAD	5.00		
INTERMEDIATE METAL CONDUIT LOCKOUT 2" WITH AMERICAN THREAD	1.00		
INTERMEDIATE METAL CONDUIT BUSHING 1" WITH AMERICAN THREAD	5.00		
INTERMEDIATE METAL CONDUIT BUSHING 2" WITH AMERICAN THREAD	1.00		
INTERMEDIATE METAL CONDUIT L&B 1" WITH AMERICAN THREAD	5.00		
INTERMEDIATE METAL CONDUIT L&B 2" WITH AMERICAN THREAD	1.00		
ELEVATOR			
3 POLE MOULDED CASE CIRCUIT BREAKER 20AT/100AF	1.00		
3 POLE MOULDED CASE CIRCUIT BREAKER 200AT/225AF	1.00		
PANEL BOARD 0-12 BRANCHES 400AMPS (ALF1124CB)	1.00		
THWN-2 STRANDED 12AWG	3.00		
THWN-2 STRANDED 4/0AWG	3.00		
INTERMEDIATE METAL CONDUIT PIPE 1/2" WITH AMERICAN THREAD	1.00		
INTERMEDIATE METAL CONDUIT PIPE 1.5" WITH AMERICAN THREAD	1.00		
INTERMEDIATE METAL CONDUIT ELBOW 1/2" WITH AMERICAN THREAD	1.00		
INTERMEDIATE METAL CONDUIT ELBOW 1.5" WITH AMERICAN THREAD	1.00		
INTERMEDIATE METAL CONDUIT COUPLING 1/2"	1.00		
INTERMEDIATE METAL CONDUIT COUPLING 1.5" WITH	1.00		
INTERMEDIATE METAL CONDUIT LOCKOUT 1/2"	1.00		
INTERMEDIATE METAL CONDUIT LOCKOUT 1.5"	1.00		
INTERMEDIATE METAL CONDUIT BUSHING 1/2"	1.00		

**PROGRAM OF WORK FOR THE PROPOSED
TUPC DORMITORY - PHASE 2**

INTERMEDIATE METAL CONDUIT BUSHING 1.5"	1.00		
INTERMEDIATE METAL CONDUIT L&B 1/2"	1.00		
INTERMEDIATE METAL CONDUIT L&B 1.5"	1.00		

MATERIAL COST
LABOR COST
DIRECT COST

VI. PHASE 700 – TELECOMMUNICATIONS & SURVELANCE

	QTY	UNIT	
Supply, installation and commissioning of all works under Phase700	1	lot	
1. Telephone line, internet access (WIFI)			
2. CCTV's Data and voice ports			

MATERIAL COST
LABOR COST
DIRECT COST

A TOTAL DIRECT COST
B OVERHEAD/CONTIGENCY/MISC
C CONTRACTOR'S PROFIT
 EVAT (12%) 12%*(A+B+C)
TOTAL ESTIMATI

Prepared by:

Engr. Brylle Ephraiem Q. Navarro
 IDO-Chairperson

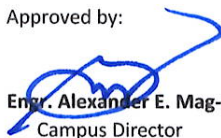
Approved by:

Engr. Alexander E. Mag-isa, Ph.D., PME
 Campus Director



TUPC DORMITORY DETAILED SCOPE OF WORKS



**TECHNOLOGICAL UNIVERSITY OF THE PHILIPPINES
CAVITE CAMPUS**

Carlos Q. Trinidad Avenue, Salawag, Dasmariñas City, Cavite, Philippines
Telefax: (046) 416-4920
Email: cavite@tup.edu.ph | Website: www.tup.edu.ph



Management System
ISO 9001:2015



www.tuv.com
ID 9108652185

1. INTRODUCTION

This Construction Scope of Work together with the drawings, applicable Engineering Standards, Bill of Quantities, and Industry Standards listed in this document, constitute the technical basis for the complete work to be performed by the CONTRACTOR for the Construction of the TUPC Dormitory, Salawag Dasmariñas City. It describes only the technical aspects of the activities required for this project and must be read in conjunction with other Contract Schedules to obtain a complete understanding of the requirements of the contract.

2. PROJECT SUMMARY

Phase 2- Construction of the TUPC Dormitory, Salawag, Dasmariñas City, Cavite

3. APPLICABLE CODE AND STANDARDS

3.1. GENERAL CODES AND STANDARDS

RA6541 National Building Code of the Philippines	2018
RA1378 Revised Plumbing Code of the Philippines	1999
RA9514-Fire Code of the Philippines	2019
RA 7920 - Philippine Electrical Code	2019
National Structural Code of the Philippines	2015

3.2. INDUSTRIAL CODES AND STANDARDS

3.3. LOCAL GOVERNMENT LAWS AND ORDINANCES

3.4. MATERIAL SPECIFICATIONS STANDARD

3.5. STANDARD AND LIBRARY DRAWINGS

A. SITE WORK

I. GENERAL

This Phase-2 Construction for the Construction of a 4-Storey Dormitory Building inside the Technological University of the Philippines – Cavite Campus, located at Brgy. Salawag, Dasmariñas City.

The described site work is the continuation of the remaining works under Phase 1 and shall include the following:

- A. Mobilization and demobilization
- B. Earthworks (Fill) and Site Clearing
- C. Slope Protection where construction of Riprap near the creek is a must with a span not less than 20 meters to secure and stabilize the soil where the dormitory stands.
- D. Establishing final grading includes leveling and preparation of the access road, stair, and other means of accessibility of the structure.
- E. Contractor temporary facilities refer adequate space for the engineers and labor force with adequate water and electricity thus also include space for proper material handling and space for the specimen.

B. DETAILED DESCRIPTION OF FACILITIES WORK

I. GENERAL



**TECHNOLOGICAL UNIVERSITY OF THE PHILIPPINES
CAVITE CAMPUS**

Carlos Q. Trinidad Avenue, Salawag, Dasmariñas City, Cavite, Philippines
Telefax: (046) 416-4920
Email: cavite@tup.edu.ph | Website: www.tup.edu.ph



Management System
ISO 9001:2015



www.tuv.com
ID 9108652185

The described facilities indicated shall be constructed in the following phase items.

All materials before fixing and installing shall submit sample for material approval to the End-user.

The Construction Contractor shall submit shop drawings for approval of TUPC Representative.

Location		Description	Area, m ²	
Ground Floor	Common Area	Lobby	32.87	
		Waiting Area	52.46	
		Stair	9.66	
		Elevator	1.44	
		Laundry Area	34.62	
		2 Toilet	2.68	
	Girls Area	4 Rooms with 3 Double Decks	115.51	
		3-2 Toilet and 1 Showers Area	26.10	
		House Mother Room Waiting Area	5.10	
		Boys Area	4 Rooms with 3 Double Decks	115.51
			3-2 Toilet and 1 Showers Area	26.10
			House Mother Room Waiting Area	5.40
Second Floor	Common Area	Lobby	25.65	
		Stair	9.66	
		Elevator	1.44	
	Girls Area	4 Rooms with 3 Double Decks	116.84	
		3-2 Toilet and 1 Showers Area	26.10	
		Mess Hall with Kitchen Area	18.26	
		Fire Exit	11.123	
	Boys Area	4 Rooms with 3 Double Decks	116.84	
		3-2 Toilet and 1 Showers Area	26.10	
		Mess Hall with Kitchen Area	18.26	
		Fire Exit	11.13	
	Third Floor		Lobby	16.62



**TECHNOLOGICAL UNIVERSITY OF THE PHILIPPINES
CAVITE CAMPUS**

Carlos Q. Trinidad Avenue, Salawag, Dasmariñas City, Cavite, Philippines
Telefax: (046) 416-4920
Email: cavite@tup.edu.ph | Website: www.tup.edu.ph



Management System
ISO 9001:2015



www.tuv.com
ID 9108652185

	Common Area	Elevator	1.44
		Fire Exit	11.13
	Faculty Bedroom	9 Rooms with 3 Single size Bed (each room), 1 Toilet Room and Shower Room	230.50
	Guest Bedroom	4 Rooms with 1 Queen size Bed (each room), 1 Toilet & Bath	69.83
Fourth Floor	Common Area	Stair	9.66
		Elevator	1.44
		Fire Exit	11.13
	Conference Room	170.33	
Roof Deck	Water Tank	7.07	
Basement	ELECTRICAL ROOMS	Main Control Panel Generator	66.86
	CONTROL ROOM	Automatic Transfer Switch	33.54
	MECHANICAL ROOM	<ul style="list-style-type: none"> ● Elevator ● Diesel Generator ● Mechanical Room ● Diesel Fire Pump ● Electric Fire pump ● Potable Water ● Booster Pump 	43.98

II. PHASE 200 – ARCHITECTURAL

The architectural design shall address all project requirements and shall be compliant to the National Building Code of the Philippines and all other relevant codes and standards.

A. Woods and Plastic

1. The contractor shall provide a Fiber Cement Ceiling Board Material for the Ceiling.
2. The door used in Toilets located in every room is PVC Flush door with louver.

B. Doors and Windows

1. Main Entrance should be Glass Material or Approved equal swing type.



**TECHNOLOGICAL UNIVERSITY OF THE PHILIPPINES
CAVITE CAMPUS**

Carlos Q. Trinidad Avenue, Salawag, Dasmariñas City, Cavite, Philippines
Telefax: (046) 416-4920
Email: cavite@tup.edu.ph | Website: www.tup.edu.ph



Management
System
ISO 9001:2015



www.tuv.com
ID 9108652185

2. The contractor shall use Steel door in every Fire Exits.
 3. The Contractor shall use is Aluminum frame Glass material sliding window located in Bedrooms and Basement.
 4. Windows use in bedrooms and facades are a wood frame awning window.
 5. Windows use in Toilets is an Aluminum frame glass material awning window.
- C. Finishes
1. Exterior and Interior walls is a Plain cement concrete finish with Paint. (See Architectural plan for reference).
 2. The Contractor shall provide Unglazed Tiles in the T&B walls. (See Architectural Plan for the detail of toilets).
 3. The Contractor shall provide Tiles for the flooring of the whole building.
- D. Specialties
1. The Contractor shall provide a curtain wall located in entrance and in the balcony on the fourth floor.
 2. The Contractor shall provide a steel railings (Painted Finish) and a Non-skid metal nosing strip located at the stairs.
 3. The Contractor shall provide a Ramp Non-Skid plain cement floor finish with Groove Lines and steel handrail (Painted Finish).
 4. The Contractor shall provide Hanging and Lower Cabinet Located at the Kitchen Area (Painted Finish). (See Architectural Plan: Cabinet Detailed Plan).
 5. The Contactor shall provide a Parapet wall design in the facade.
 6. The contractor shall provide a Wood Composite Plastic (WPC) colored: Dark Brown in the facade.
 7. The contractor shall provide a Glass Canopy on the balcony in fourth floor.
 8. The contractor shall use Wall cladding. (See Architectural Elevation Plan)
 9. The contractor shall supply Maroon Aluminum Composite Panels, Stainless Lettering (See letter size in Elevation).
 10. The Contractor shall provide a Plant box Design in the facade. (See Architectural plan for reference: Front Elevation)
 11. Provide Canopy in every windows.
 12. The contractor shall provide a steel stair located in the fire exits of the building.

III. PHASE 200 – STRUCTURAL

All concrete work shall have sample at least three (3) specimens such as for foundations, concrete walls, column beams and slabs on each pouring and floors to determine if the concrete achieves the desired strength mentioned in the General Notes. All structural materials should comply with ASTM and ACI requirements.

A. Reinforced Concrete Columns, Beams and Suspended Slabs

1. CONTRACTOR shall perform the WORK which shall include but not be limited to preparing and performing all applicable activities necessary during the construction of columns, beams, and suspended slabs.



**TECHNOLOGICAL UNIVERSITY OF THE PHILIPPINES
CAVITE CAMPUS**

Carlos Q. Trinidad Avenue, Salawag, Dasmariñas City, Cavite, Philippines
Telefax: (046) 416-4920
Email: cavite@tup.edu.ph | Website: www.tup.edu.ph



Management
System
ISO 9001:2015



www.tuv.com
ID 9108652185

Placing and removal of shoring, form work, cut bend and fix reinforcing bars, spacers, and ties (any size) as required to form columns, beams, and slabs. Provide lean concrete where required or as directed by the TUPC Engineer (PMC). The WORK shall be plumbed, true and accurate to dimensions. Pour concrete, ready mix as required or approved by the TUPC Project Engineer. Curing and protection shall start immediately after final finishing operation.

2. As soon as form work is removed, tie wire, form ties and any other embedded item shall be cut back 2.54 cm (1 inch) and holes neatly and smoothly patched. Honey combing and places with loose aggregate shall be thoroughly cleaned and patched only after the TUPC Engineer (PMC).

B. Reinforced Concrete Stairs/Steps

1. The CONTRACTOR shall perform the WORK which shall include but not be limited to preparing and performing all applicable activities necessary during the construction of reinforced concrete stairs/steps. Construct reinforced CMU walls on reinforced concrete footings to support steps. Provide and install all necessary temporary formwork and reinforcing bars. Construct cast in-situ reinforced concrete steps on prepared backfill.
2. Provide all joints including separation strips as required. Finish surfaces of steps smooth and provide chamfer to top edge of steps to the satisfaction of the TUPC Engineer (PMC) or as specified on Scope of Work or drawings.

C. Concrete Up Stand

1. The CONTRACTOR shall perform the WORK which shall include but not be limited to preparing and performing all applicable activities necessary during the construction of an up stand over the existing concrete slab. Placing and removal of form work, cut and fix (10mm or 12mm diameter) dowel bars (400- or 800-mm centers) and epoxy grouted to existing slab. The WORK shall be plumbed, true and accurate to dimensions. Pour concrete, ready mix or site mix as required or approved by the TUPC Project Engineer. Curing and protection shall start immediately after final finishing operation.

D. STRUCTURAL STEEL WORKS

1. Fire Exit Stairs
2. Railings
3. Roof truss

IV. PHASE 500 – MECHANICAL / HVAC / PLUMBING / FIRE PROTECTION / EQUIPMENT

A. HVAC

1. Provide wall or roof mounted exhaust fans complete with prefabricated roof curb at the locations as shown on drawings.
2. Provide exhaust disc valves/grilles.

B. PLUMBING

1. Provide and install cold water piping system.
2. Provide and install cold water supply by tapping-in to the external tapping point.



**TECHNOLOGICAL UNIVERSITY OF THE PHILIPPINES
CAVITE CAMPUS**

Carlos Q. Trinidad Avenue, Salawag, Dasmariñas City, Cavite, Philippines
Telefax: (046) 416-4920
Email: cavite@tup.edu.ph | Website: www.tup.edu.ph



Management
System
ISO 9001:2015



www.tuv.com
ID 9108652185

3. Provide and install various plumbing fixtures water closet, bidet spray hoses, lavatories, and kitchen sink as shown on drawings.
4. Provide and install isolation valves on all branches of water distribution network.
5. Bidet hoses spray for water closets shall be provided with vacuum breakers to prevent backflow/back-siphonage.
6. All water closet and urinal flush-o-meter valves shall be equipped with vacuum breakers to prevent water backflow/back-siphonage.
7. Provide and install water hammer arrestors to suppress surge pressure in water supply system.
8. Provide and install sanitary waste, drain, and vent piping system including plumbing specialties.
9. Provide and install various plumbing fixtures.
10. A minimum of 2% slope for drainage lines shall be maintained in horizontal run inside the building.
11. The sanitary drainage system shall be properly vented and provided with cleanouts required maintaining a free flow.
12. Provide down spouts for rainwater.

C. FIRE PROTECTION

The Mechanical-Fire Protection system shall include but not be limited to the following:

1. Provide and install complete Automatic Sprinkler System and Portable Fire Extinguishers associated piping, supports and accessories in full Compliance with applicable clauses of NFPA 13R other applicable NFPA, RA9514-Fire Code of the Philippines and applicable industry standards.
2. Provide all related piping, valves and fittings and supports required to install, test, and commission the system.
3. Provide and install fire department connection and associated check valve for the sprinkler system.

D. EQUIPMENT

1. Elevator - Basement Mechanical Room
2. Diesel Generator - Basement Mechanical Room
3. Diesel Fire Pump – Basement Mechanical Room
4. Electric Fire pump - Basement Mechanical Room
5. Potable Water Booster Pump- Basement Mechanical Room

V. PHASE 700 – ELECTRICAL

The CONTRACTOR shall provide all electrical site works required for TUPC Dormitory as detailed herein:

- A. Provide labor, materials, tools, machinery, equipment, appliances, fixtures, devices, and services necessary to complete the specified electrical work of TUPC Dormitory with other trades to prevent conflicts without impeding job progress.



**TECHNOLOGICAL UNIVERSITY OF THE PHILIPPINES
CAVITE CAMPUS**

Carlos Q. Trinidad Avenue, Salawag, Dasmariñas City, Cavite, Philippines
Telefax: (046) 416-4920
Email: cavite@tup.edu.ph | Website: www.tup.edu.ph



Management
System
ISO 9001:2015



www.tuv.com
ID 9108652185

-
- B. The Contractor shall pay fees, service charges, tap charges, meter charges, and special fees assessed by the local utilities or local authorities.
- C. A complete power distribution system including, but not limited to:
- Service entrance/provisions.
 - Switchboards/Switchgear/Unit Substations [modifications].
 - Cable feeders.
 - Panelboards.
 - Transformers.
 - Lighting Fixtures and Lamps
- D. A complete emergency power system including, but not limited to:
- Battery Emergency Power Supply
 - Generator paralleling gear
 - Automatic transfer switches and controls.
 - Cable feeders and raceways.
 - Distribution panels.
 - Panelboards.
 - Circuit Breakers
 - Transformers.
 - Enclosed circuit breakers, switches, and fuses.
 - All other components shown in the Drawings, specified, or required for a fully operational emergency power system.
- E. A complete lighting system including, but not limited to:
- Lighting fixtures and lamps.
 - Exit and egress lighting fixtures and lamps.
 - Switches, dimming and controls.
 - Branch circuit wiring and raceways.
 - All other components shown on the Drawings, specified, or required for a fully operational lighting system.
- F. A complete branch circuit distribution system including, but not limited to:
- Branch circuit wiring and raceways.
 - Wiring devices.
 - Multi-outlet assemblies.
 - Safety and disconnect switches.
 - Relays, contactors, and controls.
 - Connections to motors and equipment.
 - All other components shown in the Drawings, specified, or required for a fully operational branch circuit distribution system.
- G. A complete grounding system including, but not limited to:
- Ground Rods and Electrodes.
 - Bonding.
 - Ground conductors and raceways.
 - All other components shown on the Drawings, specified, or required for a fully operational grounding system.
- H. A complete system of miscellaneous electric controls and control wiring as shown on the Drawings and specified.



**TECHNOLOGICAL UNIVERSITY OF THE PHILIPPINES
CAVITE CAMPUS**

Carlos Q. Trinidad Avenue, Salawag, Dasmariñas City, Cavite, Philippines
Telefax: (046) 416-4920
Email: cavite@tup.edu.ph | Website: www.tup.edu.ph



Management
System
ISO 9001:2015



www.tuv.com
ID 9108652185

-
- I. CONTRACTOR shall provide supply, installation, testing and commissioning of 3 units Electric Transformers.
 - J. CONTRACTOR shall provide supply, installation, testing and commissioning of 1-unit Electric Generators w/ ATS.
 - K. Complete testing to all electrical systems.
 - L. Fire Detection and Alarm System
 1. Supply, testing, pre-commissioning and provide necessary services during commissioning, and provide initial training for new equipment, and tools for programming Fire Detection and Alarm System (Addressable type) at various locations. This shall include modules, power supply, battery, smoke and heat detectors, FACP, Manual Pull Station, Horn – Strobe, etc.
 2. The project shall ensure that all New Fire Alarm System works shall be fully coordinated with the other discipline works.
 3. Telephone Dialers shall be provided to send the signals from Fire alarm Systems to main security guard station.
 4. Note: A Dedicated Telephone Line shall be provided for this purpose for the building mentioned above.
 5. Contractor shall perform Programming of Fire Alarm system.
 6. Provide Training on Operation, Maintenance and Programming of the Fire.
 7. Provide Programming Software, Programming devices, cables including software key to the Client.
 8. Provide Fire Alarm System Back-Up Program.
 9. Provide minimum spare parts as recommended by the Manufacturer.
- VI. PHASE 780 – TELECOMMUNICATION
- VII. PHASE 700 – INSTRUMENTATION
- A. The CONTRACTOR shall supply and install the required pump instrumentation, controls, and protection for Firewater System Design.
 - B. The pump VENDOR shall supply and install the Controls and Instrumentation for Diesel Engine driven Firewater pumps.
 - C. The CONTRACTOR shall supply and install the Main Control Panel in the Electrical Room.
 - D. Supply and install indoor Automatic Transfer Switch
- C. APPLICABLE DOCUMENTS
- I. DOCUMENT CONTROL
- D. PROJECT CONTROL AND COORDINATION
- E. GENERAL REQUIREMENTS
- I. DRAWING VERIFICATION
 - II. DOCUMENTATION



**TECHNOLOGICAL UNIVERSITY OF THE PHILIPPINES
CAVITE CAMPUS**

Carlos Q. Trinidad Avenue, Salawag, Dasmariñas City, Cavite, Philippines

Telefax: (046) 416-4920

Email: cavite@tup.edu.ph | Website: www.tup.edu.ph



Management
System
ISO 9001:2015



www.tuv.com
ID 9108652185

-
- III. ENGINEERING UNITS
 - IV. AS-BUILT
 - V. WORK PERMIT
 - VI. CONSTRUCTION SCHEDULE
 - F. MATERIALS
 - I. MATERIALS
 - II. MATERIAL PROCUREMENT PLAN
 - G. QUALITY CONTROL AN QUALITY ASSURANCE
 - I. GENERAL
 - H. CLEAN UP
 - I. TESTING AND COMMISSIONING



ACQUISITION OF MINI STEAM POWER PLANT/BOILER FOR BSME PROGRAM AND CONSTRUCTION OF BOILER ROOM AT TUP CAVITE CAMPUS



ACQUISITION OF BOILER AND CONSTRUCTION OF BOILER ROOM RDIP PROFILE



REGIONAL DEVELOPMENT COUNCIL NATIONAL CAPITAL REGION (RDC-NCR)

“Where Metro Manila goes, so the country goes”

FORMULATION OF THE REGIONAL DEVELOPMENT INVESTMENT PROGRAM FOR THE NATIONAL CAPITAL REGION (RDIP-NCR) 2023-2028

IMPLEMENTING AGENCY: TECHNOLOGICAL UNIVERSITY OF THE PHILIPPINES CAVITE CAMPUS

CO-IMPLEMENTING AGENCY: NA

FOCAL PERSON: ATTY. DANILO M. ABAYON/OIC-Campus Director

CONTACT DETAILS: Carlos Q. Trinidad Avenue, Salawag, Dasmariñas City, Cavite/ (046) 416-4920

PROJECT PROFILE	
A. GENERAL INFORMATION	
TITLE	Acquisition of Mini Steam Power Plant/Boiler for BSME program and construction of Boiler Room at TUP Cavite Campus
PROGRAM¹ OR PROJECT²	<input type="checkbox"/> Program <i>Is it a regular program?³</i> <input type="checkbox"/> Yes ✓ <input type="checkbox"/> No <input checked="" type="checkbox"/> Project <i>Is this part/included in your Central Office's Public Investment Program (PIP)?</i> <input checked="" type="checkbox"/> Yes <input type="checkbox"/> No
STATUS	<input type="checkbox"/> Ongoing ⁴ <input checked="" type="checkbox"/> Proposed <input type="checkbox"/> Pipeline <input type="checkbox"/> Completed
DESCRIPTION	This is a specialized technical facility project comprising two main components: the acquisition of a Mini Steam Power Plant/Boiler, and the construction of a dedicated, safe Boiler Room to house this equipment. The definite purpose is to provide students in the BS Mechanical Engineering (BSME) program with high-fidelity, industrial-scale, hands-on training experience in energy generation, thermodynamics, and steam power operation. This facility will serve as a specialized laboratory for advanced practical instruction and technology utilization.
OBJECTIVES	This project addresses the critical gap between theoretical mechanical engineering instruction and the practical demands of industrial power generation, crucial for key sectors like Energy and Manufacturing. The acquisition of the Mini Steam Power Plant provides essential, industry-standard equipment necessary for scaling up technology adoption and hands-on utilization among future engineers. This investment ensures that graduates possess the immediate job-ready technical competencies and applied

¹ A program is a group of activities and projects that contribute to a common particular outcome. A program should have the following: a) unique expected results or outcomes; b) clear target population or client group external to the agency; c) defined method of intervention to achieve the desired result; and d) a clear management structure that defines accountabilities.

² A project is a special undertaking carried out within a definite timeframe and intended to result in some pre-determined measure of goods and services.

³ Refers to a program being implemented on a regular basis. For regular programs, only the investment targets covering 2023-2028 shall be submitted.

⁴ Ongoing P/Ps are considered ongoing if they satisfy any of the following: (a) if locally funded - upon issuance of notice to proceed; (b) if Official Development Assistance (ODA)-assisted - upon effectivity of loan or grant agreement; and (c) if PPP or Joint Venture (JV)- upon signing of concession/JV agreement including unsolicited PPP P/Ps.

PROJECT PROFILE		
	knowledge required to transform production sectors through modern industrial practices.	
COMPONENTS	The Mini Steam Power Plant/Boiler consists of a boiler unit, fuel source, steam generator, and a comprehensive system of control, instrumentation, and safety devices. The project also encompasses the construction of a dedicated Boiler Room, ensuring a safe and purpose-built space to house the mini-steam power plant ideally situated in proximity to the academic facilities of the BSME program.	
LOCATION/SCOPE	Carlos Q. Trinidad Avenue, Salawag, Dasmariñas City, Cavite	
IMPLEMENTATION PERIOD	Start of implementation: 1 st quarter of 2027 End of implementation: 4 th quarter of 2027	
EXPECTED OUTPUTS	The expected major outputs of the project include the successful procurement and installation of a Mini Steam Power Plant/Boiler, complete with a boiler unit, fuel source, steam generator, and a comprehensive system of control, instrumentation, and safety devices. Additionally, a dedicated and purpose-built Boiler Room will be constructed in close proximity to the academic facilities of the BSME program.	
LEVEL OF GAD RESPONSIVENESS⁵	<input type="checkbox"/> GAD is invisible in the program/project <input type="checkbox"/> Program/Project has promising GAD prospects <input type="checkbox"/> Program/Project is gender-sensitive <input checked="" type="checkbox"/> Program/Project is gender-responsive	
B. PROJECT FINANCING		
FINANCING SOURCE	<input checked="" type="checkbox"/> NG-Local <input type="checkbox"/> ODA Loan <input type="checkbox"/> ODA Grant <input type="checkbox"/> Internally-generated fund (for GOCCs/GFIs) <input type="checkbox"/> Private Sector <input type="checkbox"/> Others: Please specify, _____	
YEAR	Amount (separate columns per funding source, if applicable)	
	GAA/Internal Funds	Other Funding Source/s
2023	-	-
2024	-	-
2025	-	-
2026	-	-
2027	25,000,000	-
2028	-	-
Continuing Years	-	-
Total (2023-2028)	25,000,000	-
TOTAL PROJECT COST	25,000,000	-
C. TYPOLOGY		
TYPE OF P/P	<input type="checkbox"/> Major Capital Investment Program and Project <input type="checkbox"/> Technical Assistance Program/Project (such as Research and Development, Institutional Development, Human Resource Capacity Building, or System/Process Improvement PAPs) <i>Is the Technical Assistance Program/Project considered a Research and Development Program/Project?</i> <input type="checkbox"/> Yes	

⁵ Identify the Level of GAD Responsiveness of the program/project based on the score of the program/project using the appropriate Gender and Development (GAD) checklist (<https://neda.gov.ph/gender-and-development/>).

PROJECT PROFILE	
	<input type="checkbox"/> No <input type="checkbox"/> Relending Program/Project of GFIs to LGUs and Target Beneficiary <input checked="" type="checkbox"/> Government Facilities used as an office, housing, and other technical purposes
D. READINESS	
PROJECT PREPARATION DOCUMENT ACCOMPLISHED	<input type="checkbox"/> Feasibility Study F/S Cost (in exact PHP amount). _____ <i>Status:</i> <input type="checkbox"/> Completed <input type="checkbox"/> -Ongoing. Expected Completion Date: _____ <input type="checkbox"/> For Preparation. Start Date: _____ <input type="checkbox"/> Business Case <input type="checkbox"/> Project Proposal <input checked="" type="checkbox"/> Concept Note <input type="checkbox"/> Project Idea <input type="checkbox"/> Others
APPROVALS	<input type="checkbox"/> RDC-NCR Approval <i>Date of Approval:</i> _____ <input type="checkbox"/> ICC/NEDA Board Approval not required Approval/s Secured: _____ Date of Approval: _____ Approval/s Required: _____ Target Date of Approval: _____ <input type="checkbox"/> ICC/NEDA Board Approval required <i>Status of ICC/NEDA Board Approval?</i> <input type="checkbox"/> Yet to be submitted to NEDA Secretariat Target Date of Submission: _____ <input type="checkbox"/> Under the NEDA Secretariat Review Date of Submission to NEDA Secretariat: _____ <input type="checkbox"/> ICC-TB Endorsed Date of Endorsement: _____ <input type="checkbox"/> ICC-CC Approved Date of Approval: _____ <input type="checkbox"/> NEDA Board Confirmed Date of Approval: _____
LEVEL OF READINESS	<input type="checkbox"/> Level 1: With the approval of appropriate authority ⁶ but not yet ongoing <input type="checkbox"/> Level 2: Project preparation document completed; For the approval of appropriate approving body in 2022 or 2023 and for inclusion in the NEP for FY 2023 <input checked="" type="checkbox"/> Level 3: Project preparation document currently being prepared and to be completed in 2023; for approval in 2024 and for inclusion in the NEP for FY 2025
FOR ONGOING P/Ps	
PHYSICAL ACCOMPLISHMENT	NA

⁶Please attach a copy of approval

PROJECT PROFILE

FINANCIAL ACCOMPLISHMENT

Year	Amount Included/for Inclusion in the NEP	Amount Allocated in the Budget/GAA	Actual Amount Disbursed
2023	-	-	-
2024	-	-	-
2025	-	-	-
2026	-	-	-
2027	25,000,000	-	-
2028	-	-	-

E. PROJECT/PROGRAM VIABILITY

Project benefits	<p><i>This project holds the potential for positive outcomes. With efficient resource utilization and enhanced educational capabilities may yield a positive economic internal rate of return, potentially in the range of 12% to 18%, showcasing the project's financial viability. Socially, the project is significant in advancing the educational and practical capabilities of the BSME program. The hands-on experience provided by the Mini Steam Power Plant/Boiler contributes to improved student outcomes, aligning with the university's commitment to fostering innovation and excellence in engineering education.</i></p> <p><i>Moreover, the project aligns with environmental sustainability goals by focusing on the educational use of steam power technology. While the primary aim is educational, the potential for incorporating energy-efficient design and sustainable practices in the construction of the Boiler Room may contribute positively to the environment, aligning with broader sustainability objectives.</i></p>
------------------	--

Prepared by:

DARIUS L. FAJARDO
 Planning Officer
 March 02, 2026

Approved by:

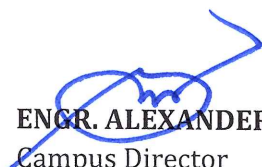
ENGR. ALEXANDER E. MAG-ISA
 Campus Director
 March 02, 2026

(as of June 26, 2023)



JUSTIFICATION ON THE ACQUISITION OF BOILER AND CONSTRUCTION OF BOILER ROOM



REPUBLIC OF THE PHILIPPINES
TECHNOLOGICAL UNIVERSITY OF THE PHILIPPINES
CAVITE CAMPUS

Carlos Q. Trinidad Avenue, Salawag, Dasmariñas City, Cavite, Philippines
Telefax: (046) 416-4920
Email: cavite@tup.edu.ph | Website: www.tup.edu.ph



Management
System
ISO 9001:2015



www.tuv.com
ID 9108652185

**JUSTIFICATION ON THE PROPOSED ACQUISITION OF MINI STEAM POWER
PLANT/BOILER FOR BSME PROGRAM AND CONSTRUCTION OF BOILER ROOM AT
TUP CAVITE CAMPUS**

Gil S. Beltran, Darius L. Fajardo & Nicka Liezl L. Kwan

Situated at the forefront of academic advancement, Technological University of the Philippines Cavite (TUPC) sees the Department of Engineering leading the institution's commitment to innovation and holistic student development. Anticipating the full implementation of the Bachelor of Science in Mechanical Engineering (BSME) program in the upcoming 1st semester of the academic year 2023-2024, TUPC envisions a transformative educational landscape that transcends conventional boundaries. In line with this vision, a proposal has been put forth for the acquisition of a mini steam power plant/boiler and the construction of a dedicated boiler room—a pivotal initiative aimed at elevating the educational and practical training experience for BSME students and allied courses in Mechanical Engineering Technology and Power Plant. The primary objective of this proposed project is to enhance the educational experience for students by providing hands-on learning opportunities, improving the curriculum, fostering research and innovation, developing technical skills, offering practical training experiences, and ensuring compliance with accreditation standards.

The Mini Steam Power Plant/Boiler designated for the BSME program and the construction of the Boiler Room at TUP Cavite Campus are specified as follows. The boiler has an equivalent output of 1500 Kg/hr with an actual output of 1275 Kg/hr and a heat output of 940 KW/kcal/hr. The boiler efficiency is rated at 90%, and it has a water content of 151 Litres. The fuel consumption is 97.0Ltrs./hr or 83.5Kg/hr, utilizing heavy oil (Bunker) as fuel. The power supply requirement is AC 200V 50/60Hz 3Ph. The boiler's dimensions are 1.840m X 2.020m X 2.510m (W x D x H). The lot price is set at P14M, considering a 10% inflation rate. Notably, the boiler excludes the heat exchanger, turbine, generator, electrical works, pipe works, and installation, which are estimated to cost up to P1M. The corresponding Boiler Room, named Thermal Engineering Laboratory, encompasses specific dimensions for the boiler space (7000mmx5000mm), which requires two individual doors in compliance with Rule 1163 of the Labor Code of the Philippines. Additionally, it includes storage space for fuel and accessories (3000mmx5000mm), a lecture area (10000mmx5000mm), a ceiling height of 3100mm with a clearance of at least 900mm as per Rule 1163, a chimney for ventilation, and provisions for adequate water supply and wastage. The room will be equipped with its own air conditioning system and lecture tables. The estimated cost for the structure of the Thermal Engineering Laboratory is about P10M.

This project aligns with the Philippine Development Plan 2023-2028, focusing on the expansion and upgrading of infrastructure in higher education institutions. It also contributes to the promotion of human and social development, emphasizing the country's commitment to international responsibilities outlined in the 17 Sustainable Development Goals (SDGs), particularly goals 4 and 9.

The end-users of this facility will primarily be the students enrolled in the BSME program and Power Plant Technology (PPT) program. Over the next decade, an estimated of more than 600 BSME students and more than 450 PPT students are expected to benefit from this hands-on learning opportunity. Additionally, faculty members from the Department of Engineering and the Department of Industrial Technology, responsible for teaching power plant operation, design, and related subjects in thermodynamics, will utilize the equipment to enhance their instructional methods.



REPUBLIC OF THE PHILIPPINES
TECHNOLOGICAL UNIVERSITY OF THE PHILIPPINES
CAVITE CAMPUS

Carlos Q. Trinidad Avenue, Salawag, Dasmariñas City, Cavite, Philippines
Telefax: (046) 416-4920

Email: cavite@tup.edu.ph | Website: www.tup.edu.ph



Furthermore, this project opens avenues for potential academic linkages, allowing the utilization of the mini steam power plant/boiler for collaborative research, joint projects, and knowledge exchange with other educational institutions. Such partnerships will contribute to the academic enrichment of both TUPC and its collaborating institutions.

In summary, the proposed acquisition and construction project not only addresses the immediate educational needs of TUP-Cavite but also positions the institution as a leader in fostering innovation, research, and academic collaboration in the field of Mechanical Engineering and Power Plant Technology. It underscores TUPC's commitment to providing a cutting-edge learning environment and contributing to the nation's development goals and international responsibilities.



BOILER ROOM DETAILED ENGINEERING DESIGN:

- ARCHITECTURAL PLAN
 - STRUCTURAL PLAN
 - ELECTRICAL PLAN
 - PLUMBING PLAN



1 PERSPECTIVE
A 000 NOT TO SCALE

ARCHITECTURAL DRAWING INDEX

- A-000 EXTERIOR PERSPECTIVE
VICINITY MAP
SITE DEVELOPMENT PLAN
GENERAL NOTES
- A-101 GROUND FLOOR PLAN
- A-102 ROOF PLAN
- A-103 FRONT ELEVATION
REAR ELEVATION
- A-104 LEFT SIDE ELEVATION
RIGHT SIDE ELEVATION
- A-105 LONGITUDINAL SECTION
CROSS SECTION
- A-106 SCHEDULE OF DOORS AND WINDOWS

Republic of the Philippines Technological University of the Philippines-Cavite OFFICE OF THE BUILDING OFFICIAL	
District/City/Municipality	
LAND USE AND ZONING	
LINE AND GRADE	
ARCHITECTURAL	
STRUCTURAL	
SANITARY	
ELECTRICAL	
MECHANICAL	

- ARCHITECTURAL NOTES
- CONTRACTOR TO SUBMIT SHOP DRAWINGS FOR ARCHITECT'S APPROVAL PRIOR TO CONSTRUCTION AND/OR INSTALLATION.
 - CONTRACTOR TO VERIFY ALL DIMENSIONS FROM EXISTING SITE CONDITIONS
 - VERIFY ALL COLUMNS, SLABS AND BEAM DIMENSIONS WITH STRUCTURAL DRAWINGS.
 - VERIFY ALL INTERIOR FINISHES AND DETAILS WITH INTERIOR DESIGN DRAWINGS.
 - ALL DIMENSIONS SHALL HAVE PREFERENCE OVER SCALE
 - THE OWNER AND THE ARCHITECT SHALL BE NOTIFIED OF ANY CORRECTIONS
 - WHERE DISCREPANCIES EXIST BETWEEN DRAWINGS OF VARIOUS TRADES, ARCHITECTURAL DRAWINGS SHALL GENERALLY BE ASSUMED TO GOVERN, CONSULT THE ARCHITECT BEFORE PROCEEDING WITH THE WORK
 - DETAILS NOT SHOWN ARE SIMILAR IN CHARACTER TO THOSE DETAILS WITH SPECIFIC DIMENSIONS, WHEREIN DESIGN INTENT CAN BE DETERMINED, CONSULT THE ARCHITECT BEFORE PROCEEDING WITH THE WORK

- LEGEND
- A. GUARD HOUSE
 - B. POWER HOUSE
 - C. MARKER/ROUND ABOUT W/ LANDSCAPING
 - D. CAMPUS FLAG POLE
 - E. ADMINISTRATION BUILDING
 - F. PROPOSED PARKING AREA
 - G. MALE AND FEMALE TOILET
 - H. ELEVATED WATER TANK
 - I. PROPOSED CISTERN
 - J. COVERED COURT
 - K. STUDENT CENTER BLDG.
 - L. NSTP BLDG.
 - M. ROTO PARADE GROUND
 - N. ACADEMIC BLDG. AND OPEN-AIR AUDITORIUM
 - O. PROPOSED NEW CHAPEL W/ LANDSCAPES
 - P. PHYSICS & CHEMISTRY BLDG.
 - Q. ENGINEERING BLDG.
 - R. ECO PARK AND MICROFARMING
 - S. FOOD COURT
 - T. RESEARCH AND EXTENSION
 - U. CET/PT/MPET BLDG.
 - V. IT/IE FACULTY BLDG.
 - W. AET BLDG.
 - X. EET/SET BLDG.
 - Y. PROPOSED CONVERSION OF EET BLDG. TO 2-STORY 4-CLASSROOM BLDG.
 - Z. PROPOSED CONVERSION OF ESET BUILDING TO 2-STORY 4-CLASSROOM BLDG.
 - AA. IT BUILDING
 - BB. BLUE BUILDING
 - CC. ART SHOP
 - DD. PROPOSED RENOVATION OF COMPUTER BUILDING
 - EE. SMART TOWER
 - FF. DRAWING AREA
 - GG. HANG AREA
 - HH. HOME ECONOMICS BUILDING
 - II. TAN CHING BUILDING
 - JJ. PROPOSED RENOVATION COMMON C.R.
 - KK. EXISTING COVERED PATHWALK
 - LL. PROPOSED LANDSCAPING
 - MM. PROPOSED COVERED PATHWALK
 - NN. ROAD EXTENSION
 - OO. PROPOSED STP
 - PP. INFORMATION TECHNOLOGY CENTER
 - QQ. PROPOSED EMPLOYEES BARACKS
 - RR. PROPOSED DORMITORY
 - SS. M.R.F.
 - TT. STUDY SHED
 - UU. LEARNING RESOURCE CENTER
 - VV. ACADEMIC BUILDING
 - EA. ENGINEERING AND ARCHITECTURE BLDG

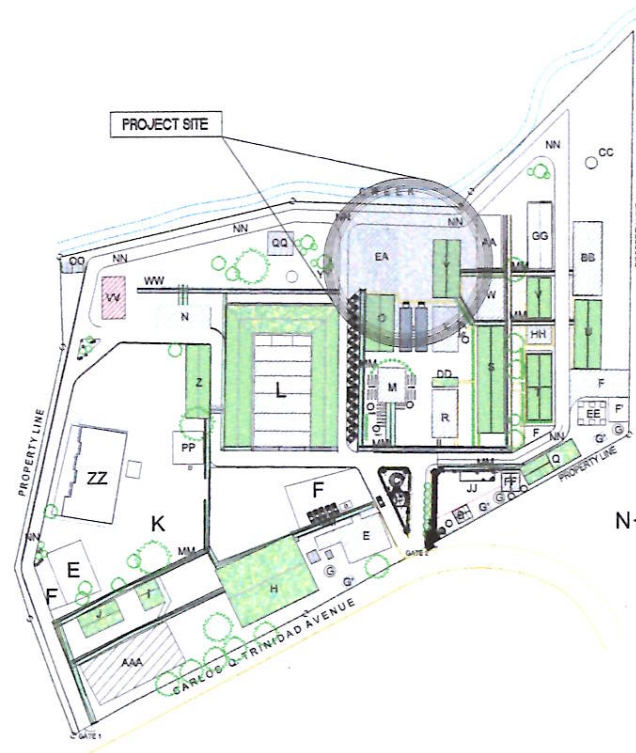

2 SITE DEVELOPMENT PLAN
A 000 NOT TO SCALE



3 VICINITY MAP
A 000 NOT TO SCALE

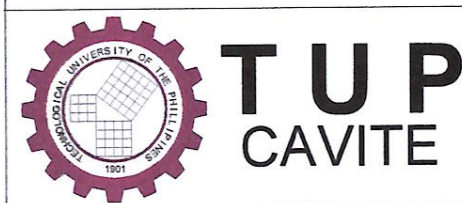

PROJECT TITLE:
PROPOSED TUPC BOILER ROOM

DESIGNED BY:
ENGR. BRYLLE EPHRAIEM Q. NAVARRO
IDO, CHAIRPERSON

APPROVED BY:
ENGR. ALEXANDER E. MAG-ISA, Ph.D., PME
CAMPUS DIRECTOR

DESIGNED BY:
IDO - CAVITE
CAD BY:
-

SHEET NO.
A
000

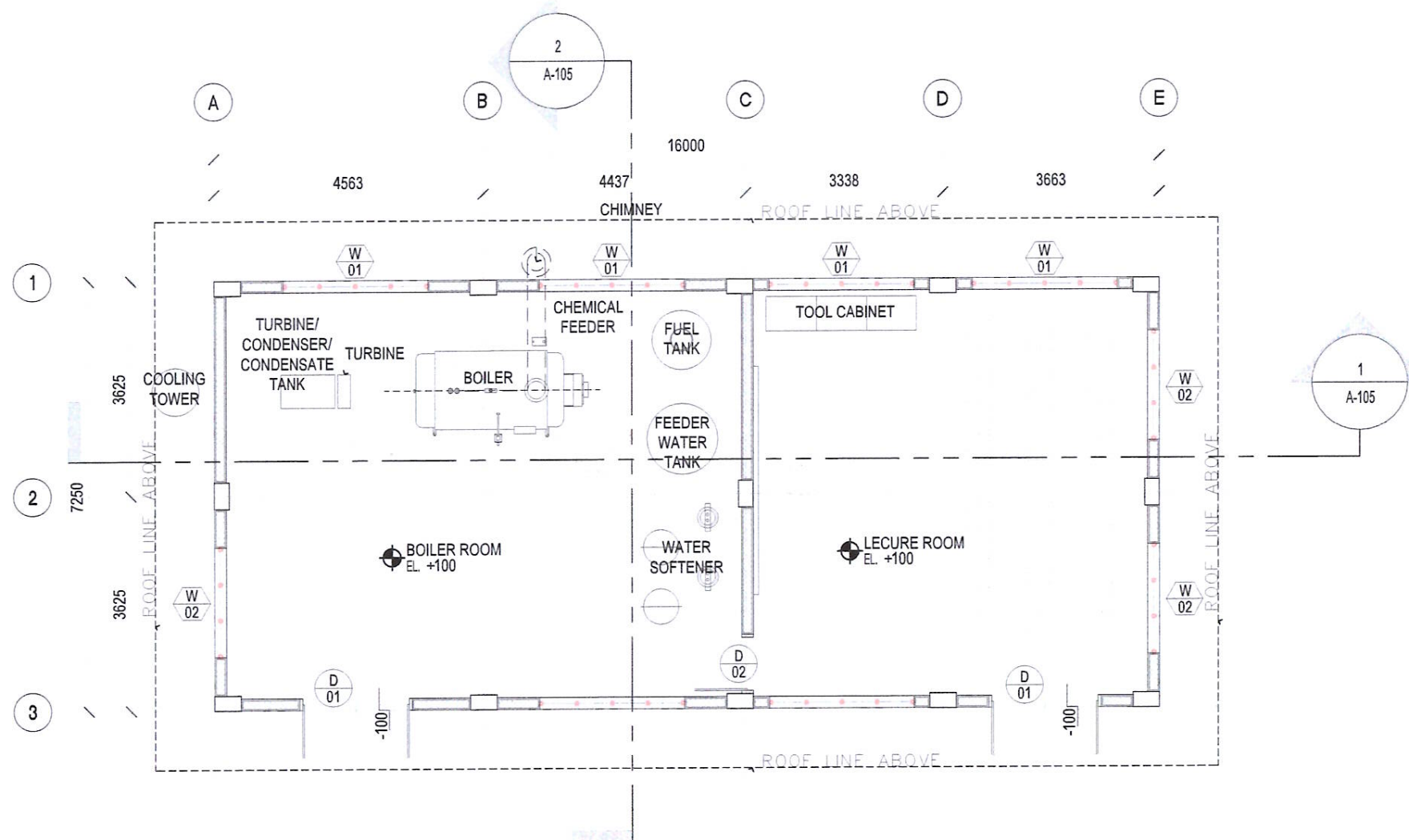

1
GROUND FLOOR PLAN
SCALE
1:100

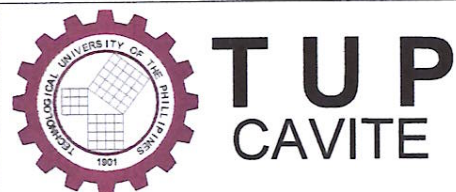

PROJECT TITLE: PROPOSED TUPC BOILER ROOM	DESIGNED BY: ENGR. BRYLLE EPHRAIEM Q. NAVARRO IDO, CHAIRPERSON	APPROVED BY: ENGR. ALEXANDER E. MAG-ISA, Ph.D., PME CAMPUS DIRECTOR	DESIGNED BY: IDO - CAVITE CAD BY: -	SHEET NO. A 101
--	---	--	--	--

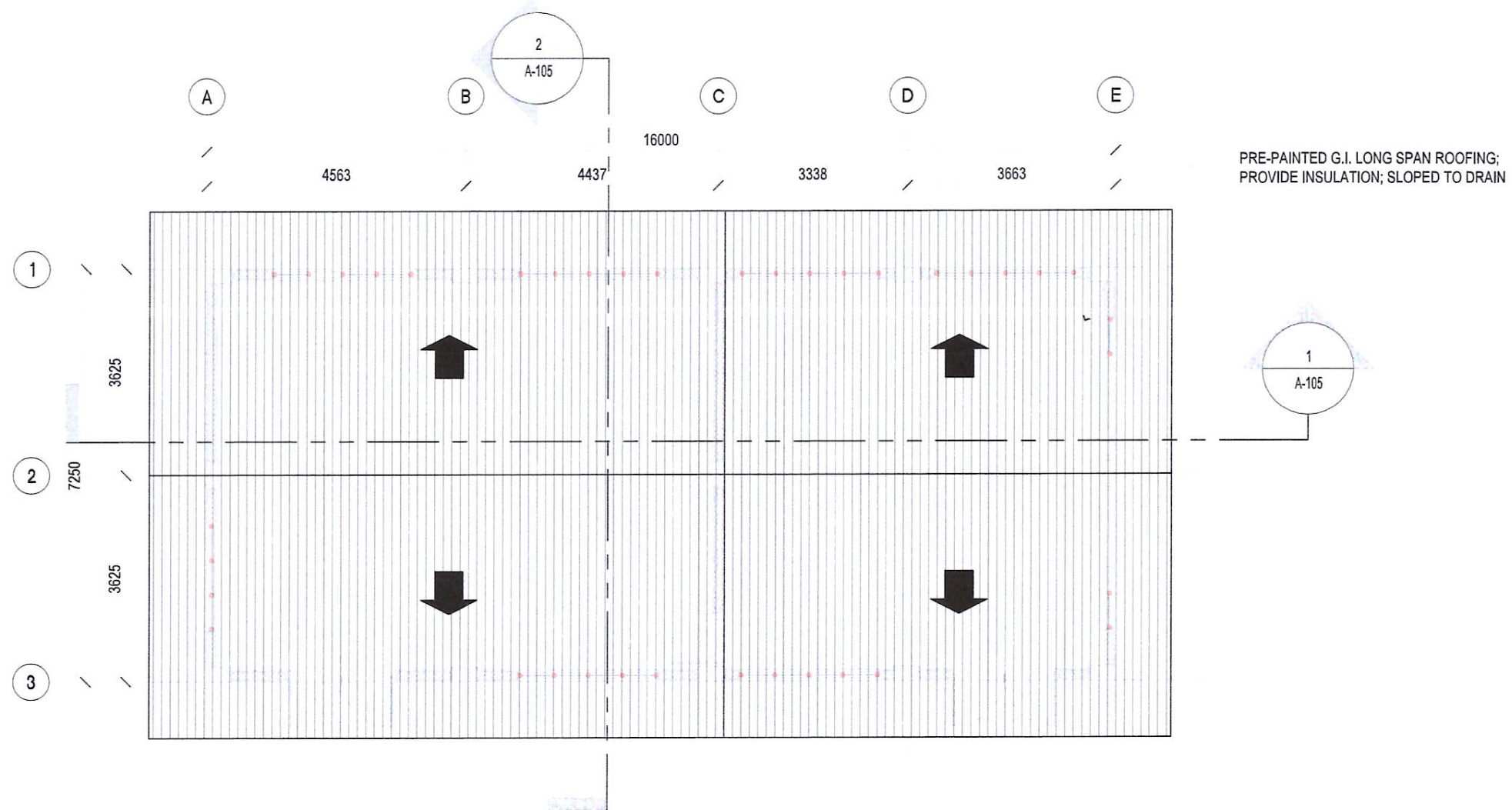

1 ROOF PLAN
A 102 SCALE 1:100



TUP
CAVITE

PROJECT TITLE:	DESIGNED BY:	APPROVED BY:	DESIGNED BY:	SHEET NO.
PROPOSED TUPC BOILER ROOM	ENGR. BRYLLE EPHRAIEM Q. NAVARRO IDO, CHAIRPERSON	ENGR. ALEXANDER E. MAG-ISA, Ph.D., PME CAMPUS DIRECTOR	IDO - CAVITE	A 102
			CAD BY: -	

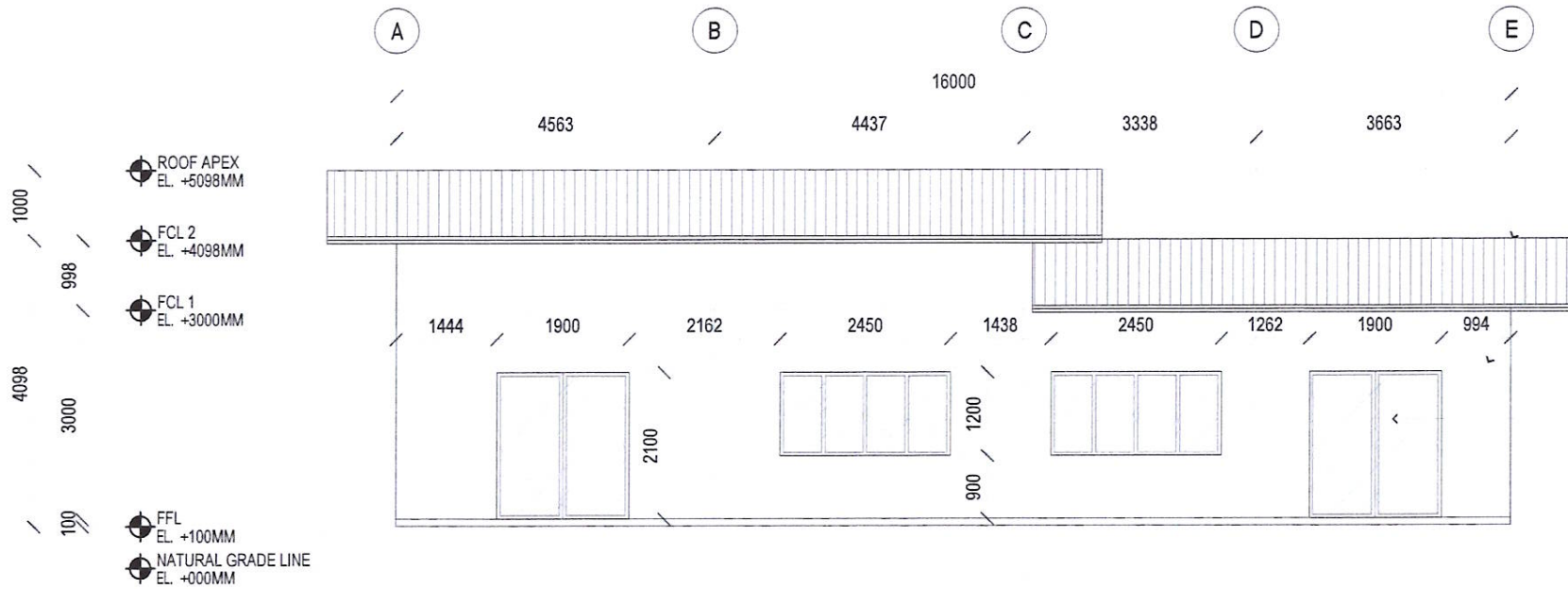

PRE-PAINTED G.I. LONG SPAN ROOFING;
PROVIDE INSULATION; SLOPED TO DRAIN

WALLS IN FAIRFACED PLAIN CEMENT
PLASTER PAINTED FINISH

DOUBLE SWING CLEAR TEMPERED GLASS
DOOR PANELS ON ALUMINUM FRAMES IN
POWDER COATED FINISH

1 FRONT ELEVATION
A 103 SCALE 1:100

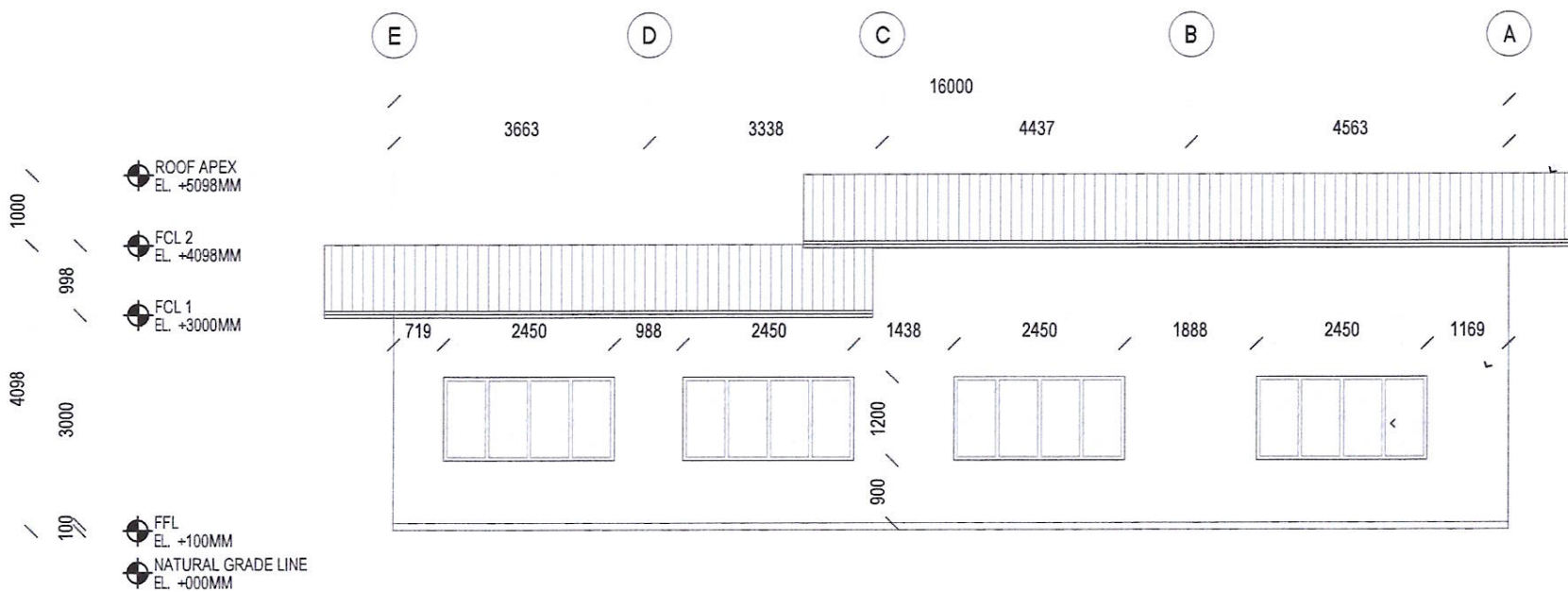

PRE-PAINTED G.I. LONG SPAN ROOFING;
PROVIDE INSULATION; SLOPED TO DRAIN

WALLS IN FAIRFACED PLAIN CEMENT
PLASTER PAINTED FINISH

STEEL CASEMENT CLEAR GLASS WINDOW
PANELS IN POWDER COATED FINISH; VERIFY
SPECS

2 REAR ELEVATION
A 103 SCALE 1:100

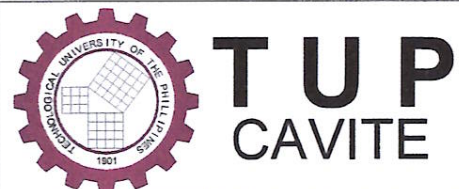

PROJECT TITLE:
PROPOSED TUPC BOILER ROOM

DESIGNED BY:
ENGR. BRYLLE EPHRAIEM Q. NAVARRO
IDO, CHAIRPERSON

APPROVED BY:
ENGR. ALEXANDER E. MAG-ISA, Ph.D., PME
CAMPUS DIRECTOR

DESIGNED BY:
IDO - CAVITE
CAD BY:
-

SHEET NO.
A
103

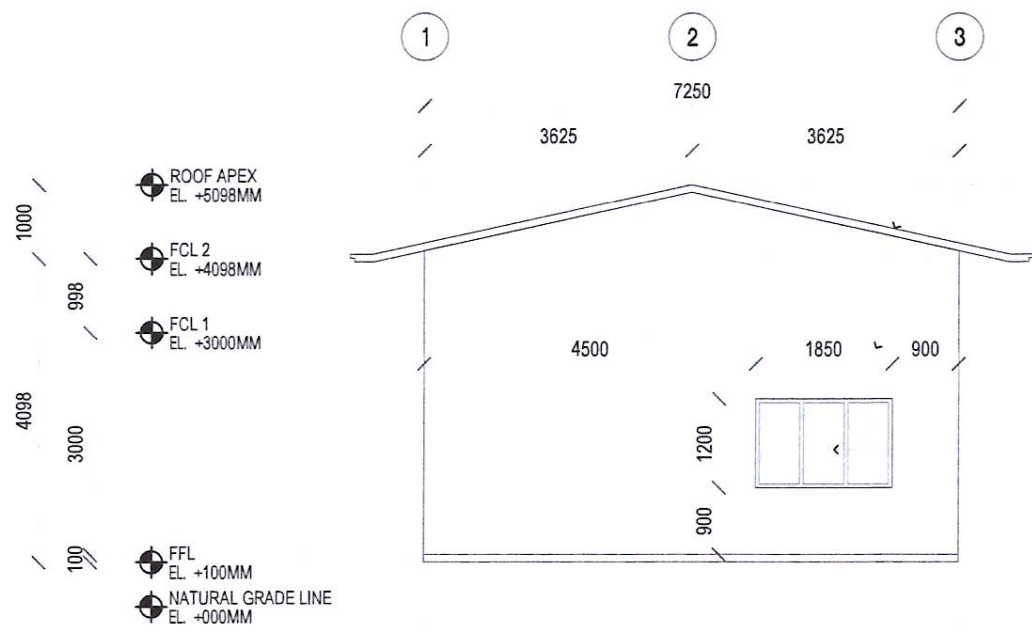

PRE-PAINTED G.I. LONG SPAN ROOFING; PROVIDE INSULATION; SLOPED TO DRAIN
 WALLS IN FAIRFACED PLAIN CEMENT PLASTER PAINTED FINISH

STEEL CASEMENT CLEAR GLASS WINDOW PANELS IN POWDER COATED FINISH; VERIFY SPECS

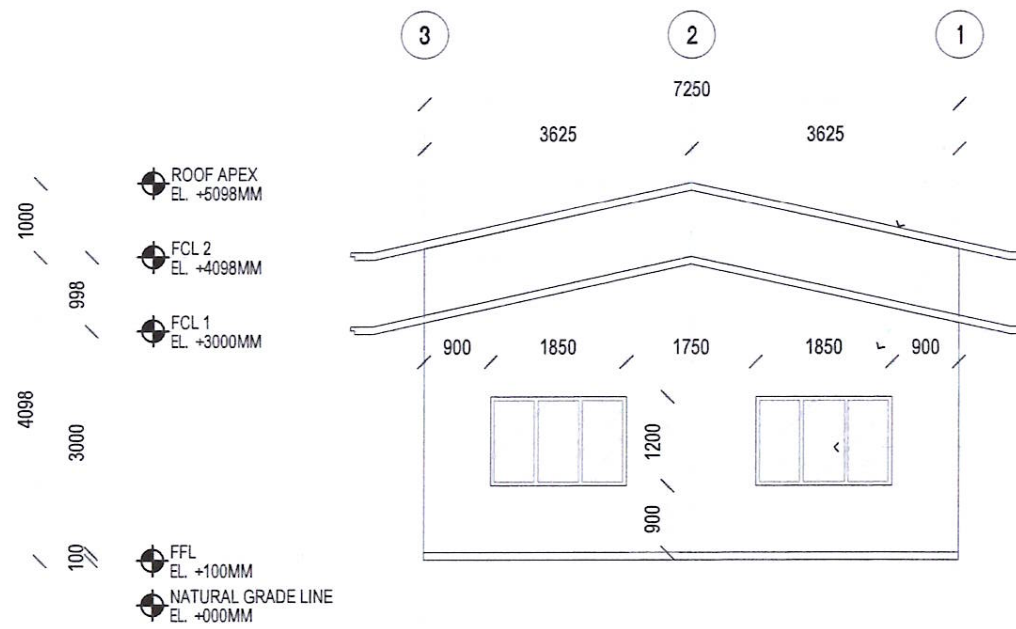

PRE-PAINTED G.I. LONG SPAN ROOFING; PROVIDE INSULATION; SLOPED TO DRAIN
 WALLS IN FAIRFACED PLAIN CEMENT PLASTER PAINTED FINISH

1 LEFT SIDE ELEVATION
 A 104 SCALE 1:100

2 RIGHT SIDE ELEVATION
 A 104 SCALE 1:100



TUP
CAVITE

PROJECT TITLE:
 PROPOSED TUPC BOILER ROOM

DESIGNED BY:
 ENGR. BRYLLE EPHRAIEM Q. NAVARRO
 IDO, CHAIRPERSON

APPROVED BY:
 ENGR. ALEXANDER E. MAG-ISA, Ph.D., PME
 CAMPUS DIRECTOR

DESIGNED BY:
 IDO - CAVITE
 CAD BY:
 -

SHEET NO.
 A
 104

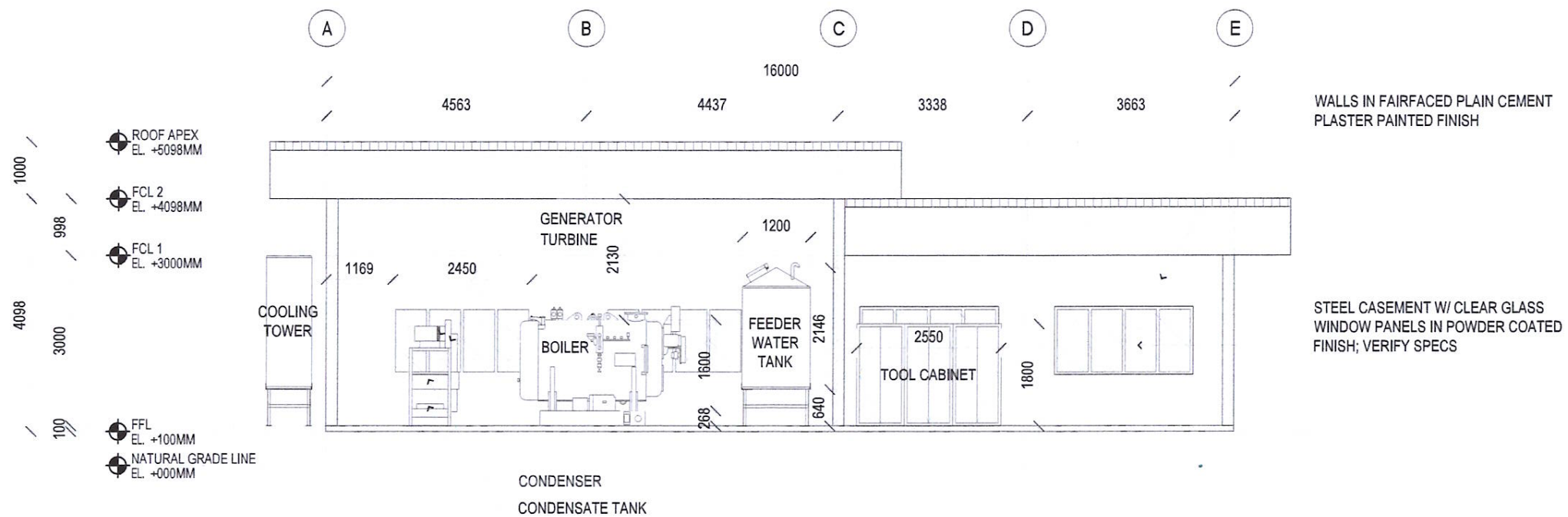

1 LONGITUDINAL SECTION
 A 105 SCALE 1:100

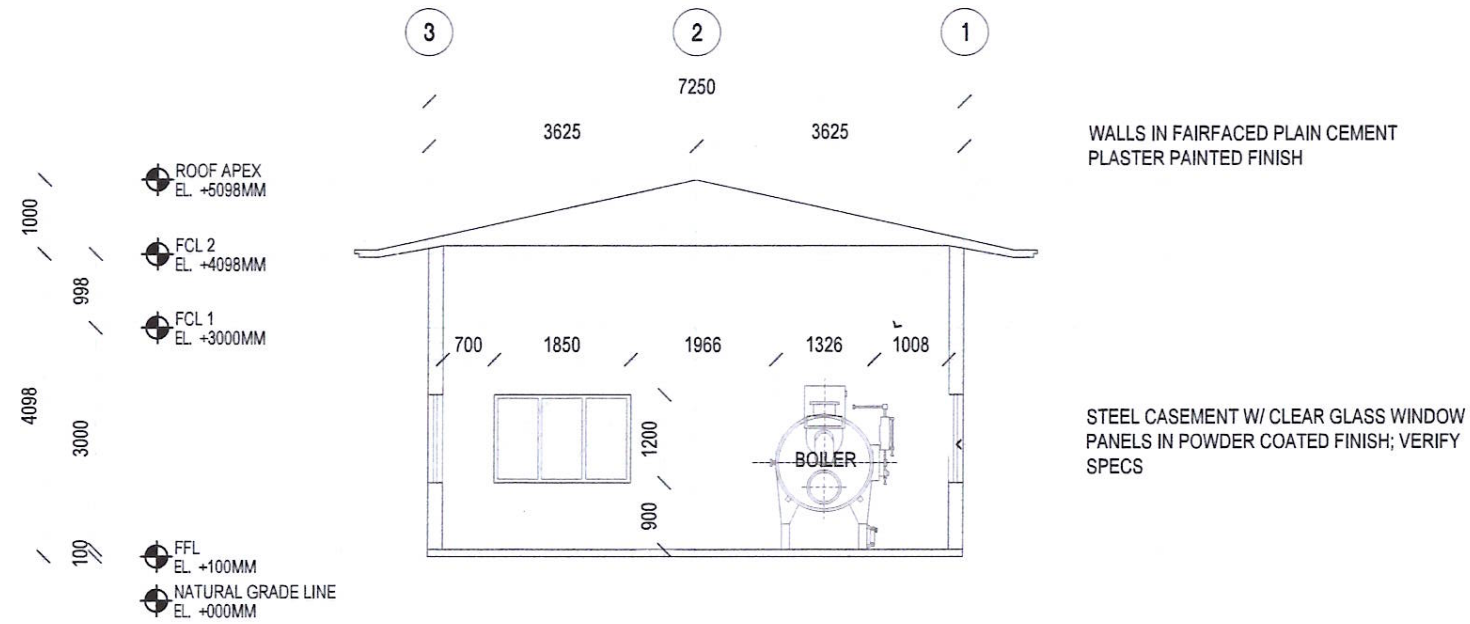

2 CROSS SECTION
 A 105 SCALE 1:100

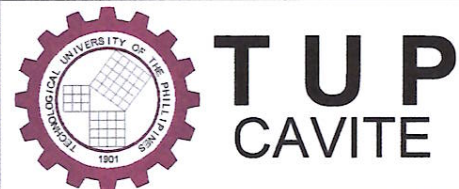

PROJECT TITLE:
 PROPOSED TUPC BOILER ROOM

DESIGNED BY:
 ENGR. BRYLLE EPARRAIEM Q. NAVARRO
 IDO, CHAIRPERSON

APPROVED BY:
 ENGR. ALEXANDER E. MAG-ISA, Ph.D., PME
 CAMPUS DIRECTOR

DESIGNED BY:
 IDO - CAVITE
 CAD BY:
 -

SHEET NO.
 A
 105

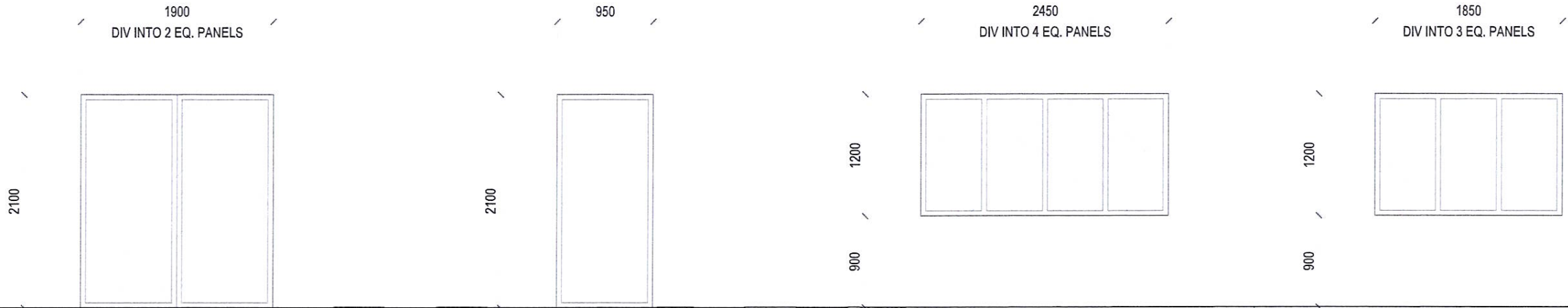

DOOR TAG/WINDOW TAG	D 01	D 02	W 1	W 1
TYPE/DESCRIPTION	DOUBLE SWING CLEAR TEMPERED GLASS DOOR PANELS ON ALUMINUM FRAMES IN POWDER COATED FINISH	SINGLE SWING CLEAR TEMPERED GLASS DOOR PANELS ON ALUMINUM FRAMES IN POWDER COATED FINISH	STEEL CASEMENT W/ CLEAR GLASS WINDOW PANELS IN POWDER COATED FINISH	STEEL CASEMENT W/ CLEAR GLASS WINDOW PANELS IN POWDER COATED FINISH
LOCATION	LECTURE ROOM/BOILER ROOM	LECTURE ROOM	LECTURE ROOM/BOILER ROOM	LECTURE ROOM/BOILER ROOM
NO. OF SETS	2	1	7	7

NOTES:

1. CONTRACTOR TO VERIFY EXISTING SITE CONDITIONS PRIOR TO IMPLEMENTATION.
2. CONTRACTOR TO VERIFY GLASS SPECIFICATION AS PER MANUFACTURER'S RECOMMENDATION.
3. COORDINATE WITH ARCHITECT AND INTERIOR DESIGNER BEFORE PROCEEDING TO WORK.

NOTE:

CONTRACTOR/ SUBCONTRACTOR/ SUPPLIER TO SUBMIT SHOP DRAWINGS FOR APPROVAL OF THE ARCHITECT PRIOR TO FABRICATION AND INSTALLATION.

ALL DOOR AND WINDOW OPENING DIMENSIONS SHOULD BE VERIFIED ON SITE.

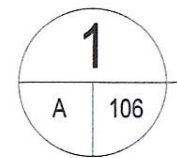

SCHEDULE OF DOORS AND WINDOWS

SCALE 1:50



**TUP
CAVITE**

PROJECT TITLE:	DESIGNED BY:	APPROVED BY:	DESIGNED BY:	SHEET NO.
PROPOSED TUPC BOILER ROOM	ENGR. BRYLLE EPHRAJEM Q. NAVARRO IDO, CHAIRPERSON	ENGR. ALEXANDER E. MAG-ISA, Ph.D., PME CAMPUS DIRECTOR	IDO - CAVITE	
			CAD BY:	A
			-	106

1.0 GENERAL :

- 1.1 ALL DIMENSIONS ARE SHOWN IN MILLIMETERS, ELEVATIONS ARE IN METERS, UNLESS NOTED OTHERWISE.
- 1.2 THE CONTRACTOR SHALL VERIFY ALL DIMENSIONS AND CONDITIONS AT THE SITE, AND SHALL NOTIFY THE ENGINEER OF DISCREPANCIES BETWEEN ACTUAL CONDITIONS AND INFORMATION SHOWN ON THE DRAWINGS BEFORE PROCEEDING WITH THE WORK. THIS SHALL INCLUDE THE LOCATIONS AND DIMENSIONS OF GROOVES, REGLETS, SLEEVES, CURBS, OPENINGS, EMBEDDED OR ATTACHED ITEMS, ETC. REFER TO ARCHITECTURAL, MECHANICAL, ELECTRICAL AND PLUMBING DRAWINGS.
- 1.3 ALL DIMENSIONS SHALL TAKE PRECEDENCE OVER SCALE SHOWN ON PLANS, SECTIONS OR DETAILS. NOTES AND DETAILS ON DRAWINGS SHALL TAKE PRECEDENCE OVER GENERAL NOTES AND TYPICAL DETAILS.
- 1.4 THE CONTRACTOR SHALL IMMEDIATELY NOTIFY THE OWNER AND/OR THE ENGINEER OF ANY CONDITION WHICH IN HIS OPINION MIGHT ENDANGER THE STABILITY OF THE STRUCTURES OR CAUSE DISTRESS IN THE STRUCTURES.
- 1.5 THE CONTRACTOR SHALL TAKE ALL STEPS NECESSARY TO ENSURE THE PROPER ALIGNMENT OF THE STRUCTURES AFTER THE INSTALLATION OF ALL STRUCTURAL AND FINISH MATERIALS.
- 1.6 CONTRACTOR SHALL BE RESPONSIBLE FOR THE COST OF ADDITIONAL WORK BY THE ENGINEER DUE TO SELECTION OF AN OPTION, SUBSTITUTION OF MATERIAL, OR DUE TO ERRORS OR OMISSION IN CONSTRUCTION BY CONTRACTOR.
- 1.7 SPECIAL NOTE: DIMENSIONS INDICATED ON THE STRUCTURAL DRAWINGS SHALL BE COORDINATED WITH THE ARCHITECTURAL DRAWINGS. ARCHITECTURAL DRAWINGS SHALL BE USED TO DEFINE DETAIL CONFIGURATIONS, ELEVATIONS, OPENINGS, JOINTS, SLOPES, ETC.
- 1.8 TYPICAL DETAILS AND GENERAL NOTES SHALL APPLY TO ALL PARTS OF THE JOB UNLESS OTHERWISE SHOWN ON THE DRAWINGS.

2.0 STANDARDS AND REFERENCES :

THE FOLLOWING SHALL GOVERN THE DESIGN, FABRICATION AND CONSTRUCTION OF THE PROJECT :

2.1 AMERICAN CONCRETE INSTITUTE (ACI PUBLICATIONS) :

- ACI 318-05 BLDG. CODE REQUIREMENTS FOR REINFORCED CONCRETE
- ACI 315-99 MANUAL OF STANDARD PRACTICE FOR DETAILS AND DETAILING OF CONCRETE REINFORCEMENT.
- ACI 301-05 STANDARD SPECIFICATION FOR STRUCTURAL CONCRETE

2.2 NATIONAL STRUCTURAL CODE OF THE PHILIPPINES (NSCP) VOL. 1, FIFTH EDITION, 2001.

3.0 BASIC DESIGN LOADS

3.1 DEAD LOADS, (D)

REINFORCED CONCRETE	24.0	kNm ³
STRUCTURAL STEEL	77.0	kNm ³
SOIL	18.0	kNm ³
WATER	9.81	kNm ³
CERAMIC TILE FLOOR FINISH	1.00	kPa
CEMENT FILL FINISH	0.70	kPa
100mm THICK CHB WALL	2.11	kPa
150mm THICK CHB WALL	2.73	kPa
CEILING	0.15	kPa
MECHANICAL & ELECTRICAL FIXTURES	0.25	kPa
MISCELLANEOUS		
MEMBRANE WATERPROOFING	0.26	kPa

3.2 OCCUPANCY LIVE LOADS, (L)

ROOF	1.0	kPa
BEDROOMS	1.9	kPa

3.3 WIND LOAD (W)

WIND LOADS ARE CALCULATED IN ACCORDANCE WITH NSCP 2001 VOLUME 1 FIFTH EDITION WITH A MINIMUM BASIC WINDSPEED OF 200 KPH (ZONE II - EXPOSURE B).

3.4 SEISMIC LOAD (E)

SEISMIC LOAD FOR BUILDINGS ARE CALCULATED IN ACCORDANCE WITH NSCP 2001 VOLUME 1 FIFTH EDITION.

SEISMIC DESIGN PARAMETERS ARE AS FOLLOWS :

SEISMIC SOURCE TYPE	B
SOIL PROFILE TYPE	S _D
SEISMIC COEFFICIENT, C _a	0.44 N _a
C _v	0.84 N _v
NEAR SOURCE FACTOR, N _a	1.0
N _v	1.0
SEISMIC ZONE FACTOR (ZONE 4)	Z = 0.40
IMPORTANCE FACTOR	I = 1.0
NUMERICAL COEFF. (NSCP TABLE 208-11)	R = 8.5 (SMRF)

4.0 MATERIALS :

4.1 NORMAL WEIGHT CONCRETE :

- 4.1.1 CONCRETE USED IN THIS WORK, UNLESS OTHERWISE STATED ON PLANS, SHALL BE READY-MIX AND HAVE A MINIMUM COMPRESSIVE STRENGTH @ 28 DAYS OF:
 - f_c' = 20.69 MPa ALL STRUCTURAL MEMBERS
 - f_c' = 20.69 MPa FOR SLAB ON GRADE (INCLUDING GUTTER) EXCEPT SPECIFIED BELOW
 - f_c' = 7.0 MPa FOR LEAN CONCRETE

- 4.1.2 ALL CONCRETE SHALL BE DEPOSITED, VIBRATED AND CURED IN ACCORDANCE WITH ACI STANDARD 318-05.

4.1.3 MIN CONCRETE COVER FOR REINFORCING BARS SHALL BE AS FOLLOWS:

- A. FOUNDATION = 75 MM (CAST AGAINST EARTH)
- B. BEAMS AND COLUMNS = 40 MM (TO STIRRUPS AND TIES)
- C. WALLS = 25 MM (CAST AGAINST FORMS)
- D. SUSPENDED SLABS = 20 MM

4.2 REINFORCING BARS :

- 4.2.1 REINFORCING STEEL SHALL BE DEFORMED AND SHALL MEET PNS/ASTM A615. THE MINIMUM YIELD STRENGTH SHALL BE AS FOLLOWS:
 - FOR Ø10 AND SMALLER:
 - f_y = 276 MPa
 - FOR Ø12 AND LARGER:
 - f_y = 414 MPa
- 4.2.2 ALL REINFORCING BARS SHALL BE CLEAN OF RUST, GREASE OR OTHER MATERIALS WHICH TEND TO IMPAIR BOND.
- 4.2.3 ALL REINFORCING BARS SHALL BE ACCURATELY AND SECURELY PLACED BEFORE POURING CONCRETE OR APPLYING MORTAR OR GROUT.
- 4.2.4 LAPPED SPLICES SHALL BE STAGGERED WHERE POSSIBLE.
- 4.2.5 UNLESS INDICATED OTHERWISE, SPlicing OF REINFORCEMENT SHALL BE IN ACCORDANCE WITH ACI STANDARD 318-08 AND SHALL NOT EXCEED THAT SPECIFIED IN ITEM 4.2.12.
- 4.2.6 UNLESS INDICATED OTHERWISE, ALL BEAMS TERMINATING AT THE COLUMN SHALL HAVE TOP AND BOTTOM BARS EXTENDING TO THE FAR FACE OF THE COLUMN, TERMINATING IN A STANDARD 90° HOOK, LENGTH OF ANCHORAGE SHALL NOT BE LESS THAN 8d_b OR 150MM.
- 4.2.7 SHOP DRAWINGS FOR BENDING AND CUTTING OF REINFORCEMENT SHALL BE SUBMITTED FOR APPROVAL TO THE ENGINEER PRIOR TO FABRICATION.
- 4.2.8 CLEAR SPACING BETWEEN REINFORCING BARS SHALL NOT BE LESS THAN:
 - 1.5d_b NOR 40MM FOR COLUMNS
 - 1.0d_b NOR 25MM FOR OTHER MEMBERS
- 4.2.9 UNLESS SHOWN OTHERWISE ON PLANS, SPLICES SHALL BE AS FOLLOWS :
 - A. BEAMS AND FOOTING TIE BEAMS :
 - AT LEAST TWO EXTRA STIRRUPS-TIES SHALL BE PROVIDED AT ALL SPLICES. THE SPLICE LENGTH SHALL NOT BE LESS THAN THE LENGTH IN TABLE OF LAP SPLICE BELOW.
 - B. COLUMNS : SPLICES WHEN PERMITTED SHALL BE MADE WITHIN THE CENTER HALF OF COLUMN HEIGHT, AND THE LAP SPLICE SHALL NOT BE LESS THAN LD SPECIFIED IN TABLE OF LAP SPLICE. THE USE OF APPROVED MECHANICAL DEVICES MAY BE PERMITTED PROVIDED THAT NOT MORE THAN ALTERNATE BARS ARE SPLICED AT ANY LEVEL AND THE MINIMUM VERTICAL DISTANCE BETWEEN TWO ADJACENT BAR SPLICES SHALL BE 600MM.
 - C. CHB WALLS : VERTICAL BARS SHALL BE SPLICED AT THE TOP OF WALL FOOTING OR TIE BEAM AND AT THE BOTTOM OF RC LINTEL BEAM OR BEAMS.

- 4.2.10 WELDING OF REINFORCEMENT IS NOT PERMITTED UNLESS OTHERWISE SHOWN ON THE DRAWINGS. WELDING OF REINFORCEMENT SHALL CONFORM TO AWS D1.4. ASTM A706 SHALL BE USED FOR WELDED REINFORCING STEEL. REINFORCEMENT NOT CONFORMING TO ASTM A706 MAY BE USED IF MATERIAL PROPERTIES OF THE REPLACEMENT STEEL CONFORM TO AWS D1.4.

- 4.2.11 DEVELOPMENT AND SPLICE LENGTHS OF REINFORCEMENT BARS SHALL BE AS FOLLOWS: BE SUBMITTED FOR APPROVAL TO THE ENGINEER PRIOR TO FABRICATION.

- 4.2.12 WELDING OF REINFORCEMENT IS NOT PERMITTED UNLESS OTHERWISE SHOWN ON THE DRAWINGS. WELDING OF REINFORCEMENT SHALL CONFORM TO AWS D1.4. ASTM A706 SHALL BE USED FOR WELDED REINFORCING STEEL. REINFORCEMENT NOT CONFORMING TO ASTM A706 MAY BE USED IF MATERIAL PROPERTIES OF THE REPLACEMENT STEEL CONFORM TO AWS D1.4.

- 4.2.11 DEVELOPMENT AND SPLICE LENGTHS OF REINFORCEMENT BARS SHALL BE AS FOLLOWS: BE SUBMITTED FOR APPROVAL TO THE ENGINEER PRIOR TO FABRICATION.

4.3 CONCRETE HOLLOW BLOCK UNITS (CHB) :

- 4.3.1 CHB USED IN THESE WORKS SHALL HAVE A MINIMUM ULTIMATE COMPRESSIVE STRENGTH @ 28 DAYS OF f_m = 2.5 MPa (350 PSI) 100/150 MM THICK NON-LOAD BEARING CHB.
- 4.3.2 ALL CELLS SHALL BE SOLIDLY FILLED WITH CONCRETE MORTAR, CONCRETE MORTAR SHALL HAVE A MINIMUM COMPRESSIVE STRENGTH OF 17.20 MPa (2500 PSI) @ 28 DAYS.

5.0 FORMWORKS :

- 5.1 FORMS SHALL BE PROVIDED FOR ALL CONCRETE NOT INDICATED OF SPECIFIED OTHERWISE. THE CONTRACTOR SHALL BE RESPONSIBLE FOR THE ADEQUACY OF FORMS AND FORM SUPPORTS. ALL FORMWORKS SHALL BE PROVIDED WITH ADEQUATE CLEAN-OUT OPENINGS TO PERMIT INSPECTION AND EASY CLEANING AFTER ALL REINFORCEMENT HAS BEEN PLACED. ALL FORMS SHALL BE CONSTRUCTED SO THAT THEY CAN BE REMOVED WITHOUT DAMAGING THE CONCRETE.

- 5.2 FORMS SHALL BE REMOVED IN A MANNER WHICH WILL PREVENT DAMAGE TO THE CONCRETE. FORMS SHALL NOT BE REMOVED, WITHOUT APPROVAL OF THE ENGINEER, OR BEFORE EXPIRATION OF THE MINIMUM PANELS SPECIFIED HEREIN:

	DAYS AFTER PLACING
FOUNDATION	1
SUSPENDED SLAB EXCEPT WHEN ADDITIONAL LOADS ARE IMPOSED	8
FORMS FOR COLUMNS (LIFTS OVER 4.5M)	7
SUPPORTING FORMS FOR SLABS, BEAMS, GIRDERS	14

SUFFICIENT SHORING TO SUPPORT THE DEAD LOAD PLUS CONSTRUCTION LOADS ON BEAMS, GIRDERS AND SLABS SHALL BE PROVIDED FOR A PERIOD OF 14 DAYS IN ADDITION TO THE 14 DAYS SPECIFIED HEREIN, PROVIDED ALL CONCRETE TEST RESULTS HAS SHOWN SUFFICIENT STRENGTH FOR 28 DAYS.

6.0 CAMBER REQUIREMENTS :

- 6.1 UNLESS OTHERWISE NOTED ON THE PLANS OR SPECIFICATIONS CAMBER ALL RC BEAMS AT LEAST 10mm. FOR EVERY 4000mm. OF CLEAR SPAN EXCEPT CANTILEVERS WHICH SHALL BE 50mm. FOR EVERY 3000mm. OF CLEAR SPAN.
- 6.2 UNLESS OTHERWISE NOTED IN PLANS OR SPECIFICATIONS, CAMBER ALL SLABS 8mm PER 3000mm. OF SHORTER SPAN AND 14mm. FOR EVERY 2000mm. OF SLABS CANTILEVER SPAN

TABLE OF LAP SPLICE

PARAMETERS													
WINDVEL (m/s)	WIND PRESSURE (kPa)	ACI DUBILE DEPTH & SPICE LENGTH	WIND PRESSURE (kPa)	ACI DUBILE DEPTH & SPICE LENGTH	WIND PRESSURE (kPa)	ACI DUBILE DEPTH & SPICE LENGTH	WIND PRESSURE (kPa)	ACI DUBILE DEPTH & SPICE LENGTH	WIND PRESSURE (kPa)	ACI DUBILE DEPTH & SPICE LENGTH			
f _c	f _y	f _y	f _c	f _y	f _c	f _y	f _c	f _y	f _c	f _y			
10	276	414	10	276	414	10	276	414	10	276			
40000	40000	40000	40000	40000	40000	40000	40000	40000	40000	40000			
BAR (mm)	ANCHORAGE LENGTH (mm)	LD (mm)	STANDARD HOOK (mm)	90°	180°	135°-90°	BEAM COMP. SPLICE (mm)	TENSION LAP SPLICE (mm)				UNIT WT. (kg/m)	
								LAP CLASS	BEAM		COLUMN		
									TOP BAR	BOTTOM BAR	TIE	SPIRAL	
10	600	170	100	110	120-120	300	A	440	340	340	340	0.616	
							B	570	440	410	410		
12	600	200	120	130-130	350		A	530	410	410	410	0.868	
							B	600	530	540	540		
16	740	270	200	130	160-160	400	A	700	540	540	540	1.570	
							B	910	700	700	700		
20	920	340	320	160	200-200	500	A	880	680	680	680	2.466	
							B	1140	880	880	880		
25	1150	430	400	200	250-250	720	A	1370	1000	1000	1000	3.854	
							B	1780	1300	1300	1300		
28	1300	480	400	200			A	1540	1180	1180	1180	4.833	
							B	2000	1530	1530	1530		
32	1700	540	550	290			A	1760	1350	1350	1350	6.313	
							B	2280	1760	1760	1760		
36	2150	610	650	300			A	1980	1520	1520	1520	7.991	
							B	2570	1980	1980	1980		

NOTES:
 1. DEVELOPMENT LENGTH OF INDIVIDUAL BARS WITHIN A BUNDLE IN TENSION OR COMPRESSION SHALL BE THAT FOR INDIVIDUAL BARS INCREASED 20% FOR THREE-BUNDLED AND 30% FOR FOUR-BUNDLED BARS.
 2. FOR COLUMNS AT ANY LEVEL, NO MORE THAN ALTERNATE BARS SHOULD BE SPLICED; NOT MORE THAN 30% OF THE BARS SHALL BE SPLICED WITHIN THE REQUIRED LAP LENGTH. MINIMUM DISTANCE BETWEEN TWO ADJACENT SPLICES SHALL BE 600mm.
 3. TOP BARS ARE HORIZONTAL BARS WITH MORE THAN 300mm DEPTH OF CONCRETE CAST BELOW REINFORCEMENT.
 4. LAP SPLICE SHALL BE "CLASS B" TENSION LAP SPLICE IF MORE THAN ONE HALF OF THE BARS WERE SPLICED AT ANY SECTION WHILE "CLASS A" TENSION LAP SPLICE IF HALF OR FEWER THAN HALF OF BARS WERE SPLICED.
 5. TOP BARS SPLICE FOR BEAMS, SHOULD BE "BEAM COMPRESSION SPLICE CLASS B".

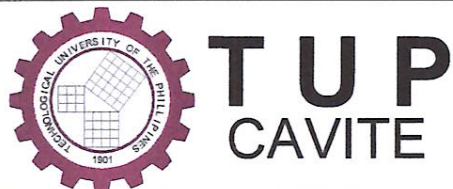

PROJECT TITLE:	DESIGNED BY:	APPROVED BY:	DESIGNED BY:	SHEET NO.
PROPOSED TUPC BOILER ROOM	ENGR. BRYLLE EPHRAIEM Q. NAVARRO IDO, CHAIRPERSON	ENGR. ALEXANDER E. MAG-ISA, Ph.D., PME CAMPUS DIRECTOR	IDO - CAVITE CAD BY:	S 01

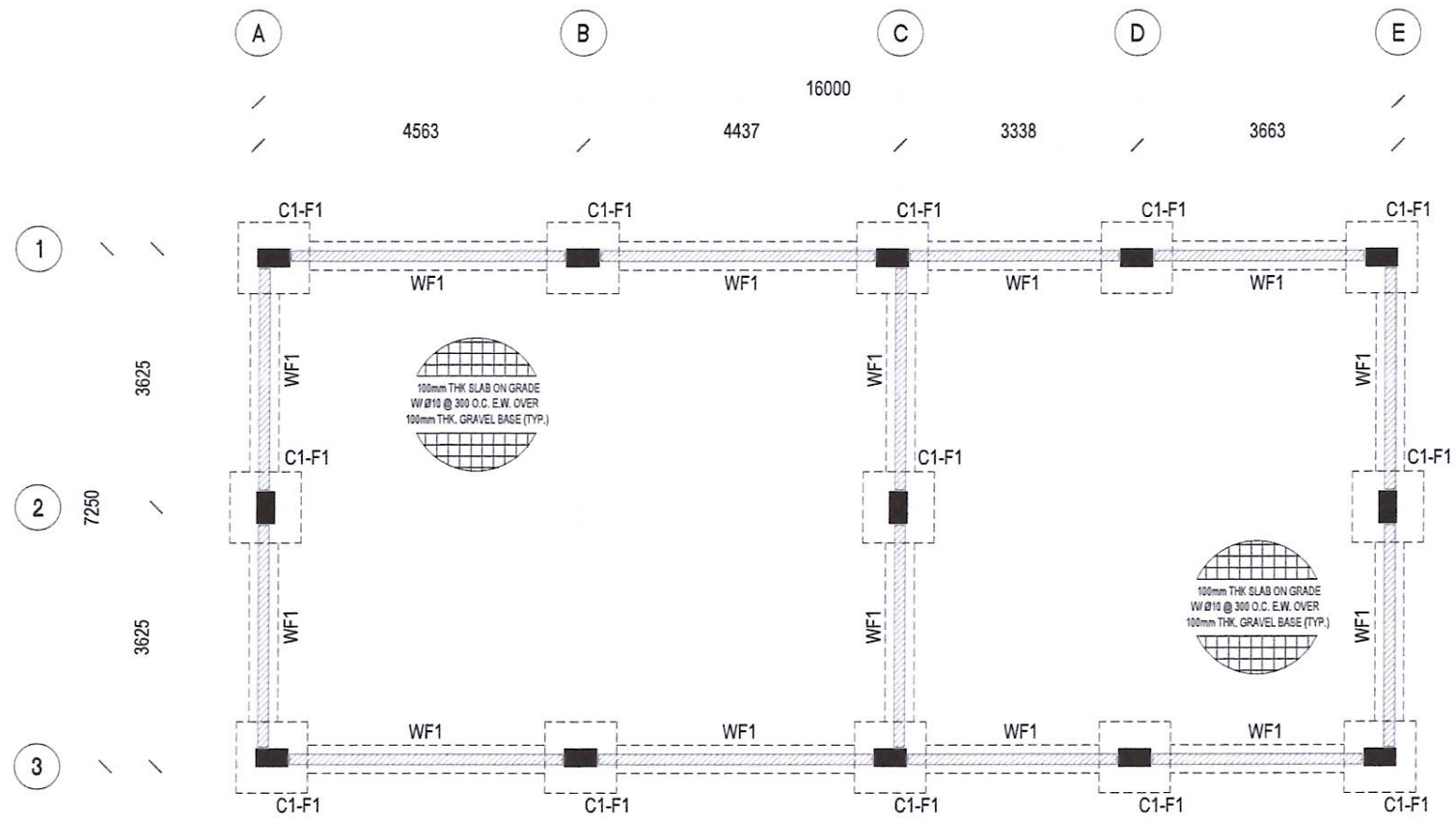

- NOTE:
1. HATCHED AREA REPRESENTS CONTINUOUS COLUMN
 2. HATCHED AREA REPRESENTS PLANTED COLUMN
 3. HATCHED AREA REPRESENTS TERMINATED COLUMN

1
FOUNDATION PLAN
 S-02 S-02 SCALE 1:100



TUP
CAVITE

PROJECT TITLE: PROPOSED TUPC BOILER ROOM	DESIGNED BY: ENGR. BRYLLE EPHRAIEM Q. NAVARRO IDO, CHAIRPERSON	APPROVED BY: ENGR. ALEXANDER E. MAG-ISA, Ph.D., PME CAMPUS DIRECTOR	DESIGNED BY: IDO - CAVITE CAD BY: -	SHEET NO. S 02
---	--	---	--	--

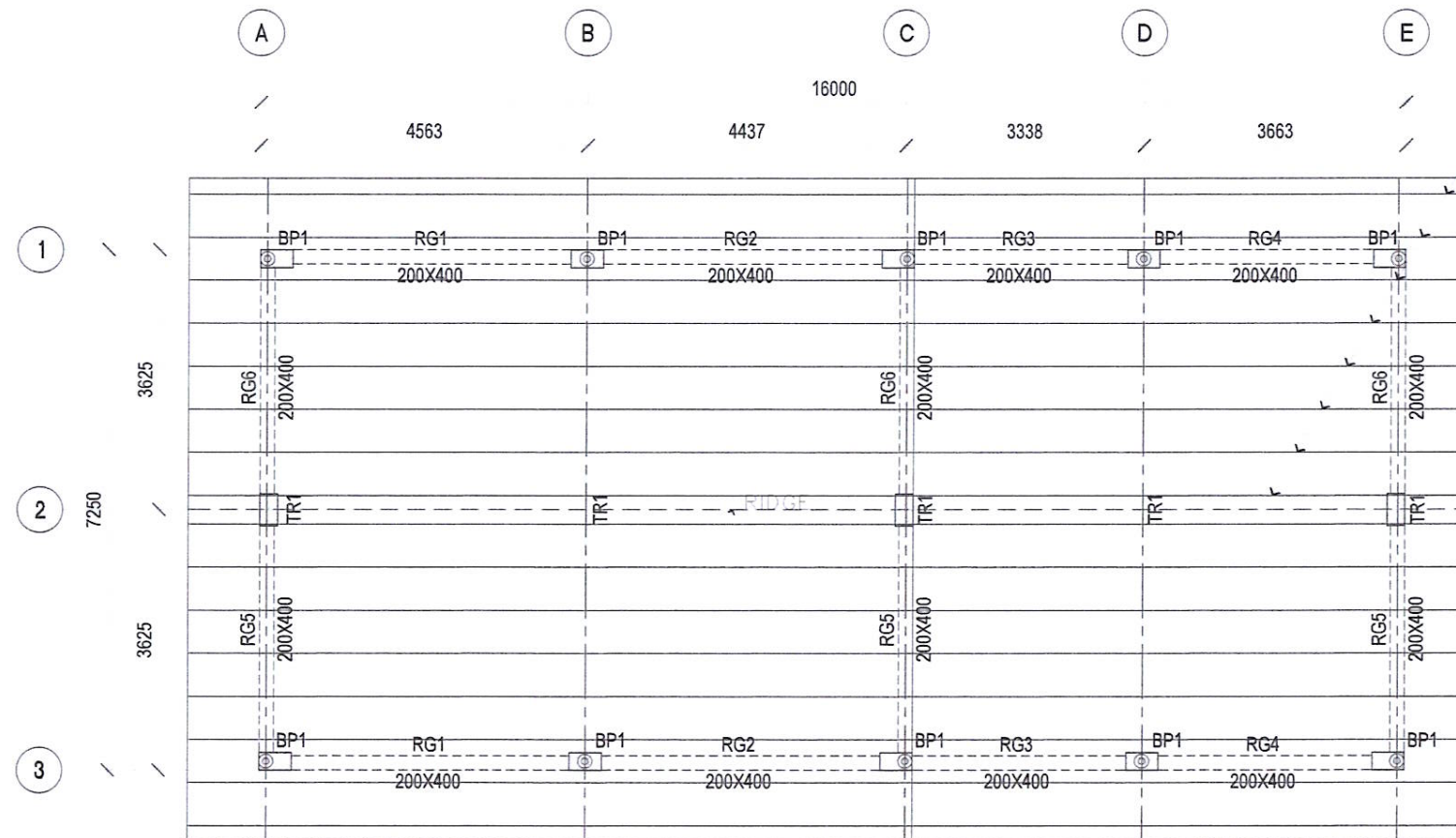

LC 100 X 50 X 15 X 4.0 SPACED @ 600mm O.C.
WITH SAG RODS @ THIRD POINTS (TYPICAL)
(SAG RODS NOT SHOWN FOR CLARITY OF
DRAWINGS)

NOTE:

- 1. HATCHED AREA REPRESENTS CONTINUOUS COLUMN
- 2. HATCHED AREA REPRESENTS PLANTED COLUMN
- 3. HATCHED AREA REPRESENTS TERMINATED COLUMN

1 ROOF FRAMING PLAN
S-03 S-03 SCALE 1:100

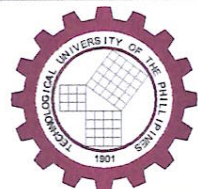

TUP
CAVITE

PROJECT TITLE:
PROPOSED TUPC BOILER ROOM

DESIGNED BY:
ENGR. BRYLLE EPHRAEM Q. NAVARRO
IDO, CHAIRPERSON

APPROVED BY:
ENGR. ALEXANDER E. MAG-ISA, Ph.D., PME
CAMPUS DIRECTOR

DESIGNED BY:
IDO - CAVITE
CAD BY:
-

SHEET NO.
S
03

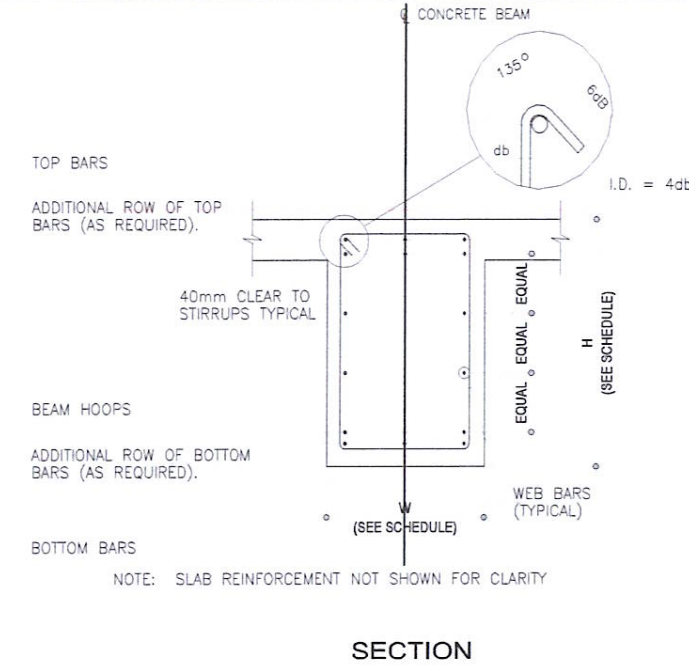
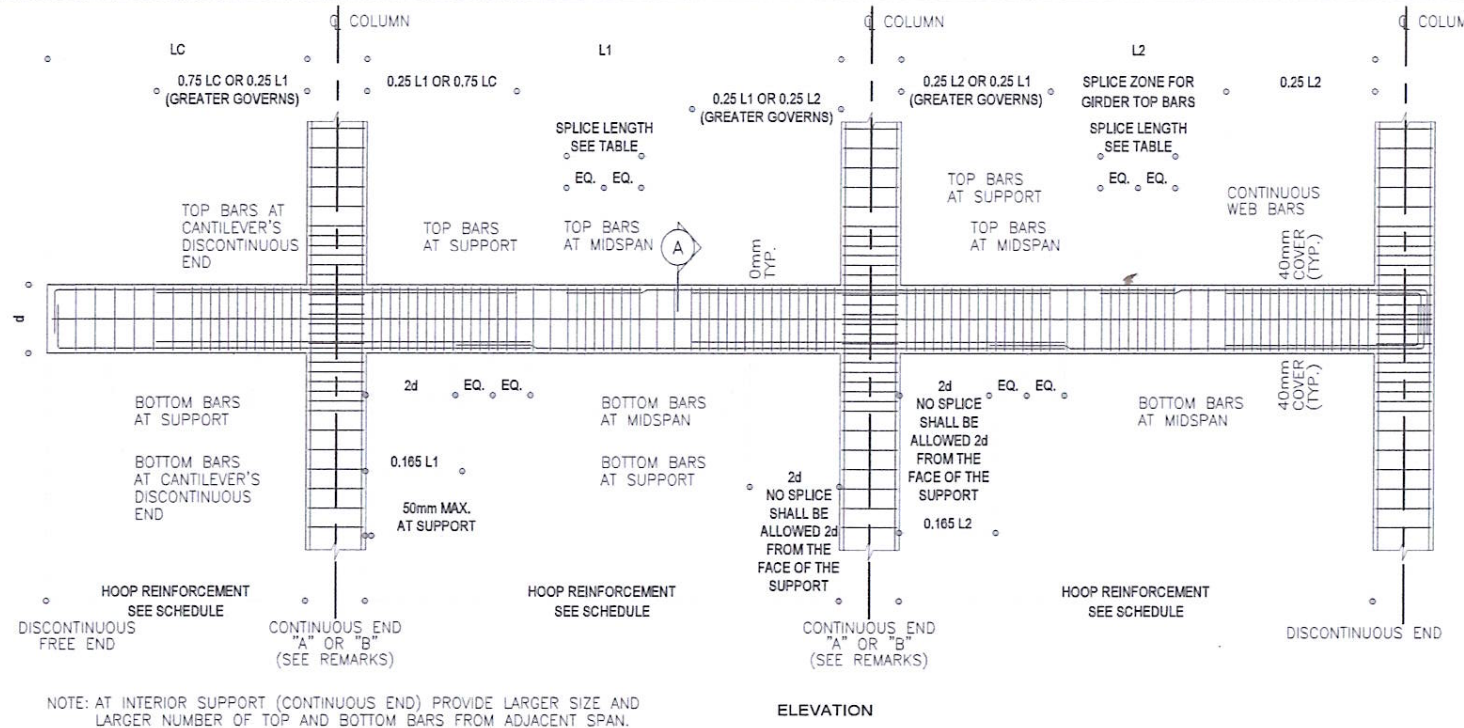

- STRUCTURAL NOTES:
1. SEE TABLE OF LAP SPLICE & ANCHORAGE LENGTHS SHOWN ON SHEET
 2. LAP SPLICE SHALL BE LOCATED ONLY WITHIN THE LAP SPLICE ZONE.
 3. TOP & BOTTOM BARS MAY BE LAP SPICED ONLY ON ONE LOCATION FOR EACH STRING OF BEAMS.
 4. CLOSED HOOPS WITH A 135° BEND SHALL BE SPACED AT 100 O.C. MAXIMUM AT A DISTANCE 2D FROM THE FACE OF THE SUPPORT. FIRST STIRRUP SHALL 5D FROM THE FACE OF THE SUPPORT.

1 TYPICAL DUCTILE MOMENT FRAME BEAM DETAIL
 S-04 S-04 NOT TO SCALE

SCHEDULE OF REINFORCED CONCRETE GIRDERS									
BEAM DESIG.	DIMENSIONS (mm)		REINFORCEMENT (mm)					SIZE & SPACING OF STIRRUPS	
	B	D	DISCONT 'A'	CONT. 'A'	MIDSPAN	CONT. 'B'	DISCONT 'B'		WEB BARS EA. FACE
ROOF LEVEL									
RG1	200	400	TB 3-Ø12mm		3-Ø12mm	3-Ø12mm			Ø10, □1@50, 8@100, REST @ 150 TO C.L.
			BB 3-Ø12mm		3-Ø12mm	3-Ø12mm			
RG2	200	400	TB	3-Ø12mm	3-Ø12mm	3-Ø12mm			Ø10, □1@50, 8@100, REST @ 150 TO C.L.
			BB	3-Ø12mm	3-Ø12mm	3-Ø12mm			
RG3	200	400	TB	3-Ø12mm	3-Ø12mm	3-Ø12mm			Ø10, □1@50, 8@100, REST @ 150 TO C.L.
			BB	3-Ø12mm	3-Ø12mm	3-Ø12mm			
RG4	200	400	TB	3-Ø12mm	3-Ø12mm		3-Ø12mm		Ø10, □1@50, 8@100, REST @ 150 TO C.L.
			BB	3-Ø12mm	3-Ø12mm		3-Ø12mm		
RG5	200	400	TB	4-Ø12mm	3-Ø12mm	4-Ø12mm			Ø10, □1@50, 8@100, REST @ 150 TO C.L.
			BB	3-Ø12mm	4-Ø12mm	3-Ø12mm			
RG6	200	400	TB		4-Ø12mm	3-Ø12mm	4-Ø12mm		Ø10, □1@50, 8@100, REST @ 150 TO C.L.
			BB		3-Ø12mm	4-Ø12mm	3-Ø12mm		

2 SCHEDULE OF CONCRETE GIRDERS
 S-04 S-04 NOT TO SCALE

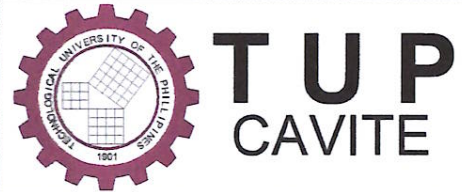

PROJECT TITLE:	DESIGNED BY:	APPROVED BY:	DESIGNED BY:	SHEET NO.
PROPOSED TUPC BOILER ROOM	ENGR. BRYLLE EPHRAEM Q. NAVARRO IDO, CHAIRPERSON	ENGR. ALEXANDER E. MAG-ISA, Ph.D., PME CAMPUS DIRECTOR	IDO - CAVITE	S 04
			CAD BY:	

SCHEDULE OF FOOTINGS							
FOOTING DESIG.	DIMENSIONS (mm)			T THICKNESS	REINF (mm)		REMARKS
	D (DEPTH)	W (WIDTH)	L (LENGTH)		BAR "X" TRANS	BAR "Y" LONG	
F1	1000	1000	1000	250	TB 5-Ø16	5-Ø16	ISOLATED FOOTING
					BB 5-Ø16	5-Ø16	

1 SCHEDULE OF FOOTING
S-05 S-05 SCALE 1:100

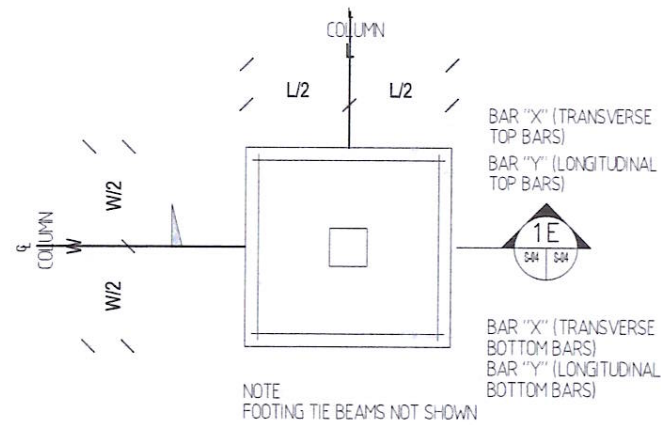

2 TYPICAL FTG. DETAIL
S-05 S-05 SCALE 1:100

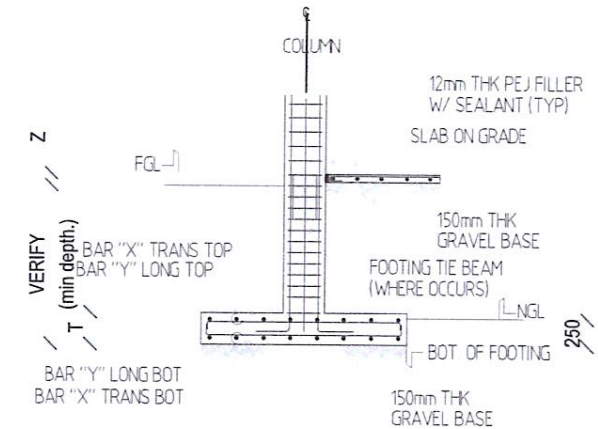

3 SECTION
S-05 S-05 SCALE 1:100

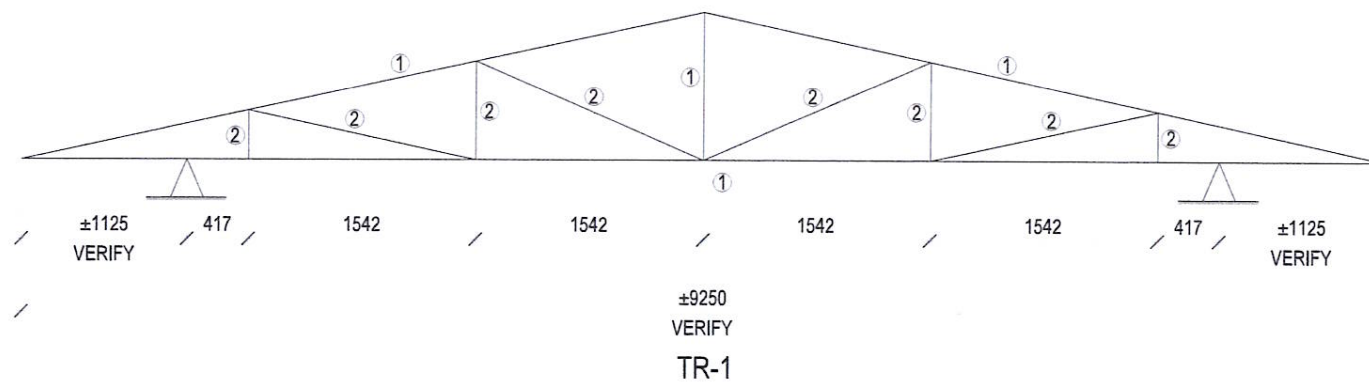

NOTE: TRUSS ELEVATION SHOWN HERE ARE STRUCTURAL LINEAR REPRESENTATIONS ONLY. ALWAYS VERIFY ACTUAL LENGTH OF TRUSSES THROUGH ARCHITECTURAL SECTIONS AND ON-SITE MOCK-UPS.

LEGEND:
1 - 2L2X2X1/4
2 - 2L2X2X1/8

4 TRUSS DIAGRAM
S-05 S-05 SCALE 1:50



TUP
CAVITE

PROJECT TITLE:	DESIGNED BY:	APPROVED BY:	DESIGNED BY:	SHEET NO.
PROPOSED TUPC BOILER ROOM	ENGR. BRYLLE EPHRAIEM Q. NAVARRO IDO, CHAIRPERSON	ENGR. ALEXANDER E. MAG-ISA, Ph.D., PME CAMPUS DIRECTOR	IDO - CAVITE	S 05
			CAD BY:	

SCHEDULE OF COLUMNS			
COL. MARK	C1		
FLOOR LEVEL			
FOOTING TO SECOND FLOOR LEVEL			
SIZE	250x450		
VERT. REINF.	6-Ø16MM		
TIES (a)	2-Ø12 @ 150MM		
CONFIN. REINF. (b)	2-Ø12 @ 100MM		
JOINT RENF. (c)	2-Ø12 @ 100MM		

1 SCHEDULE OF COLUMNS
S-06 S-06 NOT TO SCALE

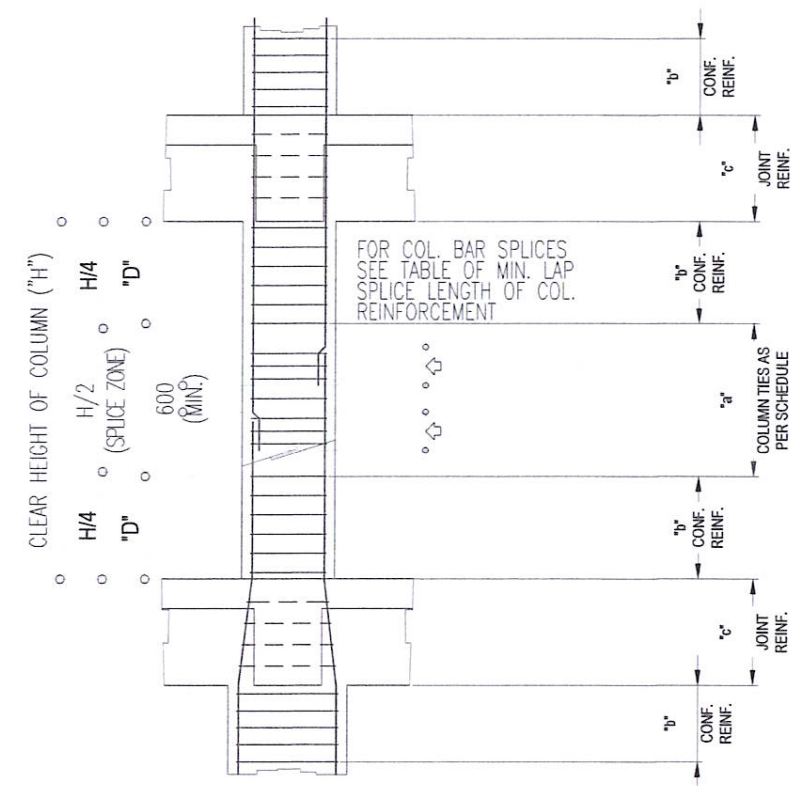

NOTES:

1. YIELD STRESS OF HOOPS = 60/40 KSI
2. D = USE MAXIMUM COLUMN/SHEARWALL DIMENSION, 1/6 CLEAR HEIGHT OR 18" (450mm) WHICHEVER IS GREATER.
3. ALL CONCRETE REINFORCEMENT DETAIL SHOULD BE DONE IN ACCORDANCE WITH ACI DETAILING MANUAL 1980 PUB SP-66
4. SPACING OF TIES WITHIN THE SPLICE SHOULD BE Ø12@100mm

2 TYPICAL COLUMN ELEVATION
S-06 S-06 NOT TO SCALE



TUP
CAVITE

PROJECT TITLE:
PROPOSED TUPC BOILER ROOM

DESIGNED BY:
ENGR. BRYLLE EPHRAIEM Q. NAVARRO
IDO, CHAIRPERSON

APPROVED BY:
ENGR. ALEXANDER E. MAG-ISA, Ph.D., PME
CAMPUS DIRECTOR

DESIGNED BY:
IDO - CAVITE
CAD BY:
-

SHEET NO.
S
06

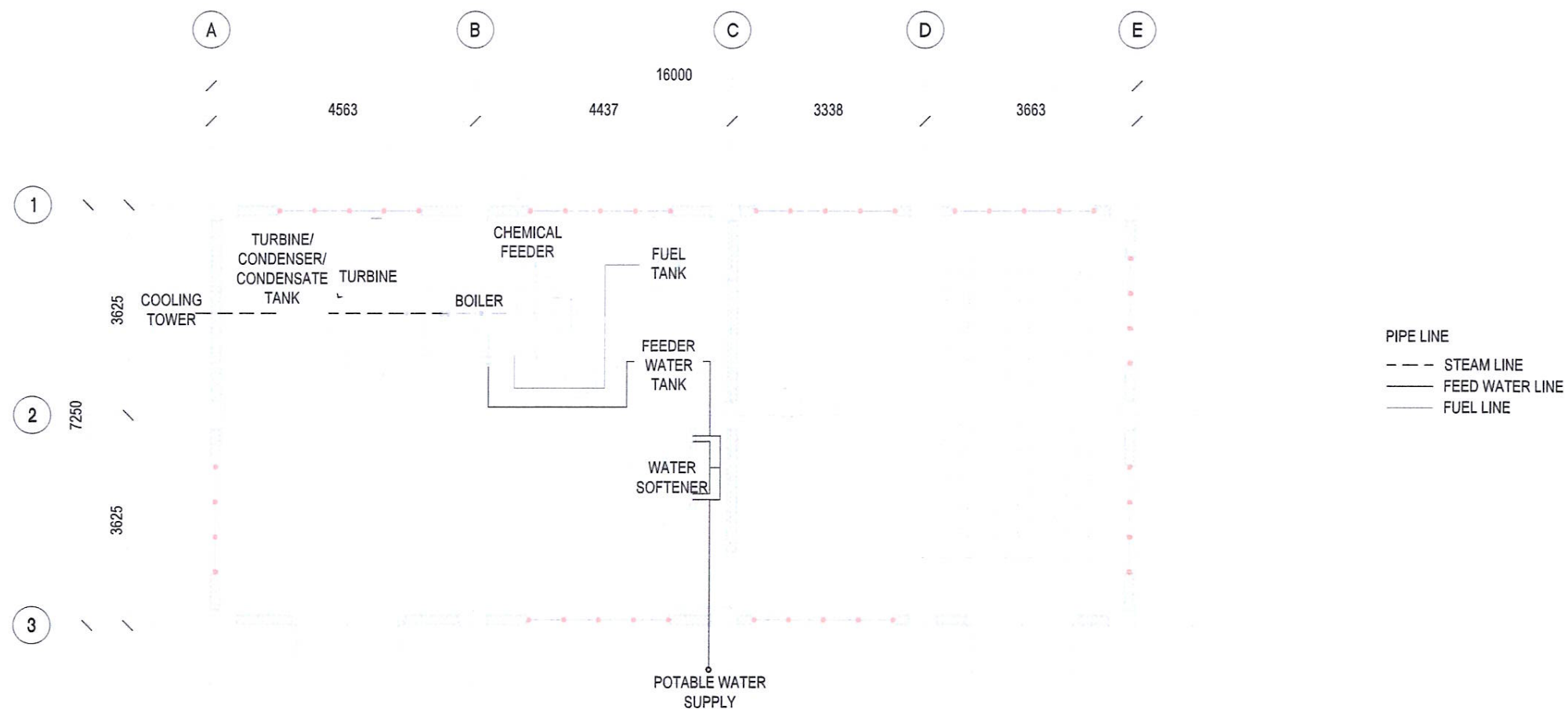

1 PIPELINE LAYOUT PLAN
 P-01 P-01 SCALE 1:100



**TUP
CAVITE**

PROJECT TITLE:
 PROPOSED TUPC BOILER ROOM

DESIGNED BY:
 ENGR. BRYLLE EPHRAIEM Q. NAVARRO
 IDO, CHAIRPERSON

APPROVED BY:
 ENGR. ALEXANDER E. MAG-ISA, Ph.D., PME
 CAMPUS DIRECTOR

DESIGNED BY:
 IDO - CAVITE
 CAD BY:
 -

SHEET NO.
 P
 01

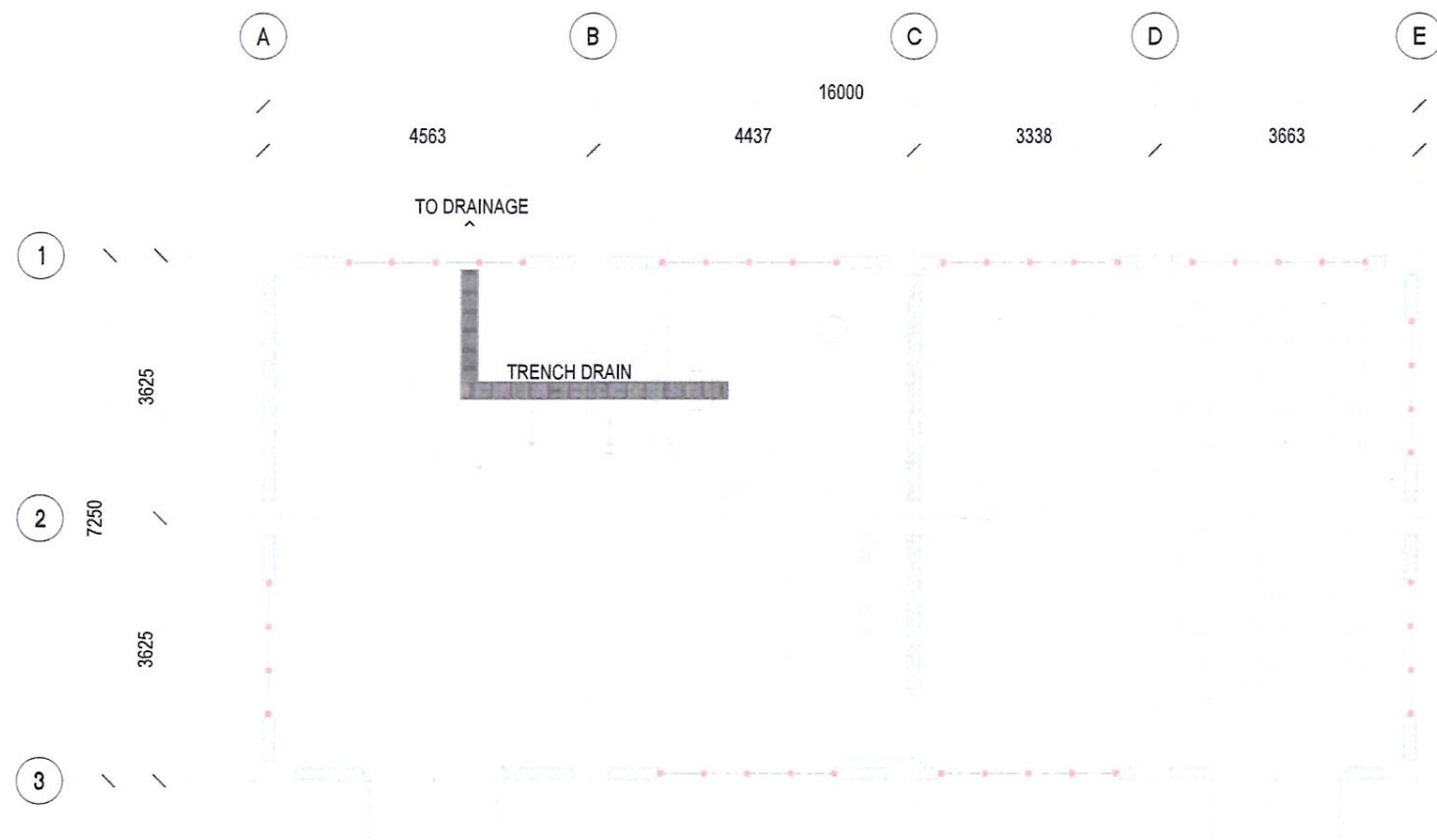

1
WASTE WATER PLAN
 P-02 P-02 SCALE 1:100

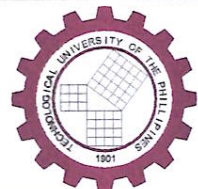

TUP
CAVITE

PROJECT TITLE:
PROPOSED TUPC BOILER ROOM

DESIGNED BY:
ENGR. BRYLLE EPHRAEM Q. NAVARRO
IDO, CHAIRPERSON

APPROVED BY:
ENGR. ALEXANDER E. MAG-ISA, Ph.D., PME
CAMPUS DIRECTOR

DESIGNED BY:
IDO - CAVITE
CAD BY:
-

SHEET NO.
P
02



ACQUISITION OF BOILER AND CONSTRUCTION OF BOILER ROOM PROGRAM OF WORK



**TECHNOLOGICAL UNIVERSITY OF THE PHILIPPINES
CAVITE CAMPUS**

Carlos Q. Trinidad Ave., Salawag, Dasmariñas City, Cavite

**PROGRAM OF WORK FOR THE PROPOSED
TUPC BOILER ROOM**

SCOPE OF WORKS

A. SITE WORK

	QTY	UNIT	UNIT PRICE	
I. GENERAL	1		33750.00 /lot	P
1. Mobilization and Demobilization				
2. Contractor Temporary Facility				
			DIRECT COST	P
II. PHASE 200 - CIVIL	1		16875.00 /lot	P
1. Grade and Compaction of the access road				
2. Established final grading				
3. Establish facilities final coordinates				
4. Facility Excavation Works				
5. Sheeting and Shoring				
6. Dewatering procedure (if required)				
			DIRECT COST	P

B. FACILITIES WORK

I. GENERAL	1		30000.00 /lot	P
1. All Necessary Permits				
2. Submit Complete Shop Drawing (as required)				
3. SAFETY Provisions				
			DIRECT COST	P
II. PHASE 200 - ARCHITECTURAL	1		318000.00 /lot	P
1. ROOFING				
2. DOORS AND WINDOWS				
3. FINISHES				
4. SPECIALTIES				
			MATERIAL COST	P
			LABOR COST	
			DIRECT COST	P

	QTY	UNIT	UNIT PRICE	
III. PHASE 200 - STRUCTURAL	1		1164700.00 /lot	P
1. Reinforced Concrete Foundations & Cast In-Situ Retaining Walls (Ready mix)				
2. Wall Foundations				
3. Reinforced Concrete Slab On-Grade				
4. Reinforced Concrete Columns, Beams and Suspended Slabs (Ready mix)				
5. Reinforced Concrete Stairs/Steps				
6. Concrete Up Stand and parapet wall				
7. Steel Works				

MATERIAL COST P
 LABOR COST
 DIRECT COST P

IV. PHASE 500 – MECHANICAL / HVAC / PLUMBING / FIRE PROTECTION / EQUIPMENT 1 lot 129500.00 /lot P
 1. HVAC
 2. Plumbing
 3. Fire Protection
 4. Equipment
 5. Testing and Commissioning

MATERIAL COST P
 LABOR COST
 DIRECT COST P

V. PHASE 700 - ELECTRICAL 1 lot 279000 /lot P
 1. Switchboards - Panel boards and breakers
 2. Wiring Devices
 3. Lighting fixtures and switches
 4. Grounding System
 5. Fire Detection and Alarm System
 6. Transformer and Generator Set
 7. Testing and Commissioning

MATERIAL COST P
 LABOR COST P
 DIRECT COST P

VI. PHASE 1000 - OTHER SPECIALIZED EQUIPMENT 1 lot 4500000 /lot P
 1. VENTILATION EQUIPMENT
 2. OTHER RELATED EQUIPMENT FOR BOILER

DIRECT COST P

A TOTAL DIRECT COST P
B OVERHEAD/CONTIGENCY/MISC
C CONTRACTOR'S PROFIT
 EVAT (12%) 12%*(A+B+C)
TOTAL ESTIMATED PROJECT COST P

Prepared by:

 Engr. Bayle Y. Fraiem Q. Navarro
 IDO-Chairperson

Approved by:

 Engr. Alexander E. Mag-Isa, Ph.D., PME
 Campus Director



CONSTRUCTION OF ARCHITECTURE AND ENGINEERING BUILDING AT TUP CAVITE (PHASE I)



RDIP PROFILE OF ARCHITECTURE AND ENGINEERING BUILDING AT TUP CAVITE (PHASE I)



REGIONAL DEVELOPMENT COUNCIL NATIONAL CAPITAL REGION (RDC-NCR)

“Where Metro Manila goes, so the country goes”

FORMULATION OF THE REGIONAL DEVELOPMENT INVESTMENT PROGRAM FOR THE NATIONAL CAPITAL REGION (RDIP-NCR) 2023-2028

IMPLEMENTING AGENCY: TECHNOLOGICAL UNIVERSITY OF THE PHILIPPINES CAVITE CAMPUS

CO-IMPLEMENTING AGENCY: NA

FOCAL PERSON: ATTY. DANILO M. ABAYON/OIC-Campus Director

CONTACT DETAILS: Carlos Q. Trinidad Avenue, Salawag, Dasmariñas City, Cavite/ (046) 416-4920

PROJECT PROFILE	
A. GENERAL INFORMATION	
TITLE	Construction of Architecture and Engineering Building at TUP Cavite Campus
PROGRAM¹ OR PROJECT²	<input type="checkbox"/> Program <i>Is it a regular program?³</i> <input type="checkbox"/> Yes ✓ <input type="checkbox"/> No <input checked="" type="checkbox"/> Project <i>Is this part/included in your Central Office's Public Investment Program (PIP)?</i> <input checked="" type="checkbox"/> Yes <input type="checkbox"/> No
STATUS	<input type="checkbox"/> Ongoing ⁴ <input checked="" type="checkbox"/> Proposed <input type="checkbox"/> Pipeline <input type="checkbox"/> Completed
DESCRIPTION	This is a purpose-built academic facility designed to significantly expand and modernize the learning environment for Architecture and various Engineering programs. The components include state-of-the-art classrooms, specialized engineering laboratories for hands-on practical experience, computer-aided design (CAD) studios, and collaborative spaces to support both theoretical and project-based learning. The facility's definite purpose is to provide a modern, comprehensive educational environment to raise the quality and capacity of technical education.
OBJECTIVES	The primary objective is to address the development gap of limited and outdated specialized instructional capacity required to deliver globally competitive technical education in high-demand fields like Architecture and Engineering. By providing modern laboratories and collaborative spaces, the project directly supports the Subchapter 2.2 outcome of attaining globally competitive and inclusive higher education. This expanded capacity will ensure that graduates possess the competencies and practical experience

¹ A program is a group of activities and projects that contribute to a common particular outcome. A program should have the following: a) unique expected results or outcomes; b) clear target population or client group external to the agency; c) defined method of intervention to achieve the desired result; and d) a clear management structure that defines accountabilities.

² A project is a special undertaking carried out within a definite timeframe and intended to result in some pre-determined measure of goods and services.

³ Refers to a program being implemented on a regular basis. For regular programs, only the investment targets covering 2023-2028 shall be submitted.

⁴ Ongoing P/Ps are considered ongoing if they satisfy any of the following: (a) if locally funded - upon issuance of notice to proceed; (b) if Official Development Assistance (ODA)-assisted - upon effectivity of loan or grant agreement; and (c) if PPP or Joint Venture (JV)- upon signing of concession/JV agreement including unsolicited PPP P/Ps.

PROJECT PROFILE	
	needed to thrive in the world of work, driving the growth of key employment sectors like Construction.
COMPONENTS	The project is a comprehensive initiative designed to address the specific requirements of architecture and engineering programs. The facility, envisioned as a center for academic excellence and innovation, is composed of five floors, each meticulously planned to cater to the diverse needs of students and faculty. The ground floor includes Lecture room 1 and Lab room 2, while the second, third, fourth, and fifth floors are designed with Lecture room 1, Lab room 2, and Lab room 3. The rooms are strategically allocated to provide dedicated spaces for lectures, laboratories, and collaborative activities. The total floor area of 1,248.49 square meters ensures ample space for more than 1,000 students simultaneously, meeting the National Building Code's minimum standard of 1 square meter per student. The distribution of lecture rooms and laboratories adheres to the guidelines set forth by the National Building Code and CHED Memorandum, ensuring that the design aligns with the facility features necessary to support the academic needs of the anticipated 576 engineering students. The inclusion of specialized laboratories in engineering, CAD studios, and collaborative spaces reflects a holistic approach to creating an environment that fosters learning, creativity, and practical skill development in the fields of architecture and engineering.
LOCATION/SCOPE	Carlos Q. Trinidad Avenue, Salawag, Dasmariñas City, Cavite
IMPLEMENTATION PERIOD	Start of implementation: 1 st quarter of 2026 End of implementation: 4 th quarter of 2027
EXPECTED OUTPUTS	The enhanced capacity of the facility is intricately tailored to accommodate the expected 576 engineering students, offering them a conducive and well-equipped environment to support their academic endeavors. The project envisions a holistic learning environment that goes beyond traditional classrooms, providing diversified spaces such as lecture rooms for theoretical knowledge and specialized labs for hands-on practical applications. This approach aims to contribute significantly to the comprehensive development of students pursuing studies in architecture and engineering, ensuring a well-rounded educational experience. Furthermore, the overall design of the project is strategically focused on creating a dynamic hub for collaboration and research. This hub is intended to be a catalyst for collaborative learning, cutting-edge research initiatives, and the cultivation of practical skills, ultimately fostering an enriched and comprehensive educational environment at TUP Cavite Campus.
LEVEL OF GAD RESPONSIVENESS⁵	<input type="checkbox"/> GAD is invisible in the program/project <input type="checkbox"/> Program/Project has promising GAD prospects <input type="checkbox"/> Program/Project is gender-sensitive <input checked="" type="checkbox"/> Program/Project is gender-responsive
B. PROJECT FINANCING	
FINANCING SOURCE	<input checked="" type="checkbox"/> NG-Local <input type="checkbox"/> ODA Loan <input type="checkbox"/> ODA Grant <input type="checkbox"/> Internally-generated fund (for GOCCs/GFIs) <input type="checkbox"/> Private Sector <input type="checkbox"/> Others: Please specify, _____
YEAR	Amount (separate columns per funding source, if applicable)

⁵ Identify the Level of GAD Responsiveness of the program/project based on the score of the program/project using the appropriate Gender and Development (GAD) checklist (<https://neda.gov.ph/gender-and-development/>).

PROJECT PROFILE		
	GAA/Internal Funds	Other Funding Source/s
2023	-	-
2024	-	-
2025	-	-
2026	-	-
2027	77,500,000	-
2028	77,500,000	-
Continuing Years	-	-
Total (2023-2028)	155,000,000	-
TOTAL PROJECT COST	155,000,000	-

C. TYPOLOGY

TYPE OF P/P

Major Capital Investment Program and Project
 Technical Assistance Program/Project (such as Research and Development, Institutional Development, Human Resource Capacity Building, or System/Process Improvement PAPs)

Is the Technical Assistance Program/Project considered a Research and Development Program/Project?

Yes
 No

Relending Program/Project of GFIs to LGUs and Target Beneficiary
 Government Facilities used as an office, housing, and other technical purposes

D. READINESS

PROJECT PREPARATION DOCUMENT ACCOMPLISHED

Feasibility Study
 F/S Cost (in exact PHP amount). _____
Status:
 Completed
 -Ongoing. Expected Completion Date: _____
 For Preparation. Start Date: _____

Business Case
 Project Proposal
 Concept Note
 Project Idea
 Others **Detailed Engineering Design**

APPROVALS

RDC-NCR Approval
Date of Approval: _____

ICC/NEDA Board Approval not required
 Approval/s Secured: _____
 Date of Approval: _____

Approval/s Required: _____
 Target Date of Approval: _____

ICC/NEDA Board Approval required
Status of ICC/NEDA Board Approval?
 Yet to be submitted to NEDA Secretariat
 Target Date of Submission: _____
 Under the NEDA Secretariat Review
 Date of Submission to NEDA Secretariat: _____

PROJECT PROFILE

ICC-TB Endorsed
 Date of Endorsement: _____
 ICC-CC Approved
 Date of Approval: _____
 NEDA Board Confirmed
 Date of Approval: _____

LEVEL OF READINESS

Level 1: With the approval of appropriate authority⁶ but not yet ongoing

Level 2: Project preparation document completed; For the approval of appropriate approving body in 2022 or 2023 and for inclusion in the NEP for FY 2023

Level 3: Project preparation document currently being prepared and to be completed in 2023; for approval in 2024 and for inclusion in the NEP for FY 2025

FOR ONGOING P/Ps

PHYSICAL ACCOMPLISHMENT NA

FINANCIAL ACCOMPLISHMENT

Year	Amount Included/for Inclusion in the NEP	Amount Allocated in the Budget/GAA	Actual Amount Disbursed
2023	-	-	-
2024	-	-	-
2025	-	-	-
2026	-	-	-
2027	77,500,000	-	-
2028	77,500,000	-	-

E. PROJECT/PROGRAM VIABILITY

Project benefits

The project is poised to generate positive economic and financial returns, along with notable social and environmental benefits. The emphasis on creating a purpose-built facility tailored to the specific needs of architecture and engineering programs suggests a potential economic and financial internal rate of return (IRR) in the range of 10-15% or higher. The inclusion of cutting-edge classrooms, specialized laboratories in engineering, CAD studios, and collaborative spaces is likely to contribute positively to the educational environment, potentially resulting in a benefit-cost ratio (BCR) greater than 1. The project underscores the institution's commitment to providing a modern and comprehensive educational environment, aligning with the evolving demands of architecture and engineering disciplines. Socially, the initiative aims to enhance the learning experience for students, fostering academic excellence and innovation. Environmentally, while the primary focus is on educational infrastructure, the project's design considerations may contribute to sustainable practices, aligning with principles of environmental responsibility.

⁶Please attach a copy of approval

PROJECT PROFILE

Prepared by:

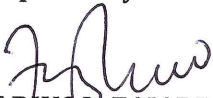
DARIUS L. FAJARDO
Planning Officer
March 02 2026

Approved by:

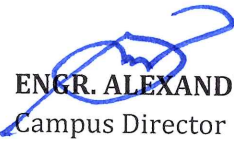
ENGR. ALEXANDER E. MAG-ISA
Campus Director
March 02, 2026

(as of June 26, 2023)



FEASIBILITY STUDY OF ARCHITECTURE AND ENGINEERING BUILDING AT TUP CAVITE (PHASE I)



Republic of the Philippines
TECHNOLOGICAL UNIVERSITY OF THE PHILIPPINES - CAVITE CAMPUS

Carlos Q. Trinidad Ave., Salawag, Dasmariñas City, Cavite

Website: <http://www.tup.edu.ph>

E-mail Add.: tupc.diroff@gmail.com

Telefax: (046) 4164920

FEASIBILITY STUDY ON THE
PROPOSED CONVERSION OF ARCHITECTURE AND ENGINEERING BUILDING

Darius L. Fajardo & Nicka Liezl L. Kwan

This feasibility study deals with the proposed conversion of the architecture and engineering building located at the Technological University of the Philippines – Cavite Campus. The capabilities and capacities of the proposed building were defined based on the physical design in accordance with the policies, standards, and guidelines set forth by the Commission on Higher Education (CHED) for Engineering. Current conditions of the engineering building were explicitly discussed in relation to the ideal set-up.

I. Campus History

The establishment of a campus of the Technological University of the Philippines (TUP) in Cavite was realized through the initiative of the Vice President for Administration Bayani Gutierrez under TUP President Jose Vergara, and was approved, by the Board of Regents on December 6, 1979 through Resolution No. 1895 s. 1979.

The establishment of the Cavite campus was in response to the demand for an institution of higher learning that can serve as an avenue for training technicians and skilled workers associated to the fast-growing industries in the region.

Technological University of the Philippines at Cavite (TUPC) stands on five-hectare land along Carlos Q. Trinidad Avenue in Salawag, Dasmariñas, Cavite, which was donated by the benevolent, Hon. Helena Benitez. A Memorandum of Agreement between TUP and the Philippine Women’s University (PWU) dated February 14, 1981 stated, “PWU shall donate five (5) hectares of land to TUP, and TUP shall build facilities to house URC and such other facilities” abetted the realization of bringing Technology Education to Cavite.

Upon the release of the General Appropriations Act of 1981, Batas Pambansa 131, and the Deed of Donation in January 1982, operations in the Campus commenced with the following officials: Prof. Carlos Trinidad as Executive Director, Dr. Erlinda Manalang as Assistant Executive Director, Dr. Emeliana Tadeo as Academic Coordinator, Prof. Enrico Hilario as Technical Arts Coordinator, and Prof. Dominador Mendoza Jr. as Administrative Coordinator.

TUPC began its instruction to a pioneer of 92 students on July 16, 1982 with 15 faculty members and 10 administrative staff. Initially, TUPC offered two-year Technician Education Programs in the areas of Civil Technology, Electrical Technology, Electronics Technology, Mechanical Technology and Automotive Technology. A year later, it added to its offerings on two-year Technical courses in Drafting Technology and Stationary Marine Engineering.

Through the dynamic leadership of Professor Trinidad and the strong support of, then, TUP President Frederick So Pada, major developments took place. More infrastructures were built to accommodate the growing student population, and the increasing number of faculty members and administrative staff. Degree programs were additionally offered to provide further professional growth and development of students who aspired of becoming teachers, engineers, technicians and skilled workers.

After the demise of Prof. Trinidad in 1999, equally capable figures took the directorship in the Cavite Campus: Prof. Susan Nunez, Officer-in-Charge, 1997 and 1999; Prof. Enrico Hilario, Campus Director, 2000-2006; Dr. Olympio Caparas, Campus Director 2006-2007; Dr. Dionisio Espression Jr. 2007-2009; Dr. Myrna Tepora, Officer-in-Charge 2009; Dr. Reynaldo Jorda 2009-2010, Dr. Myrna Fernando in 2010-2014 and Dr. Andres Z. Taguiam 2014-2015.

The transition of the sound and effective leadership of the Campus Directors and other officials resulted in developments and transformation of the Cavite Campus into a recognized center of higher learning in the field of Technology Education. It became the home to competent industrial educators, skilled engineers and technologists in various institutions and industries in the local, national, and international level.

II. Geographical Description and Survey of the Site

Figure 1, shows the site development plan of the campus. With its printed and surveyed lot plan, the campus can utilize the whole land for planning and development of the site for providing quality and more responsive programs in the future.

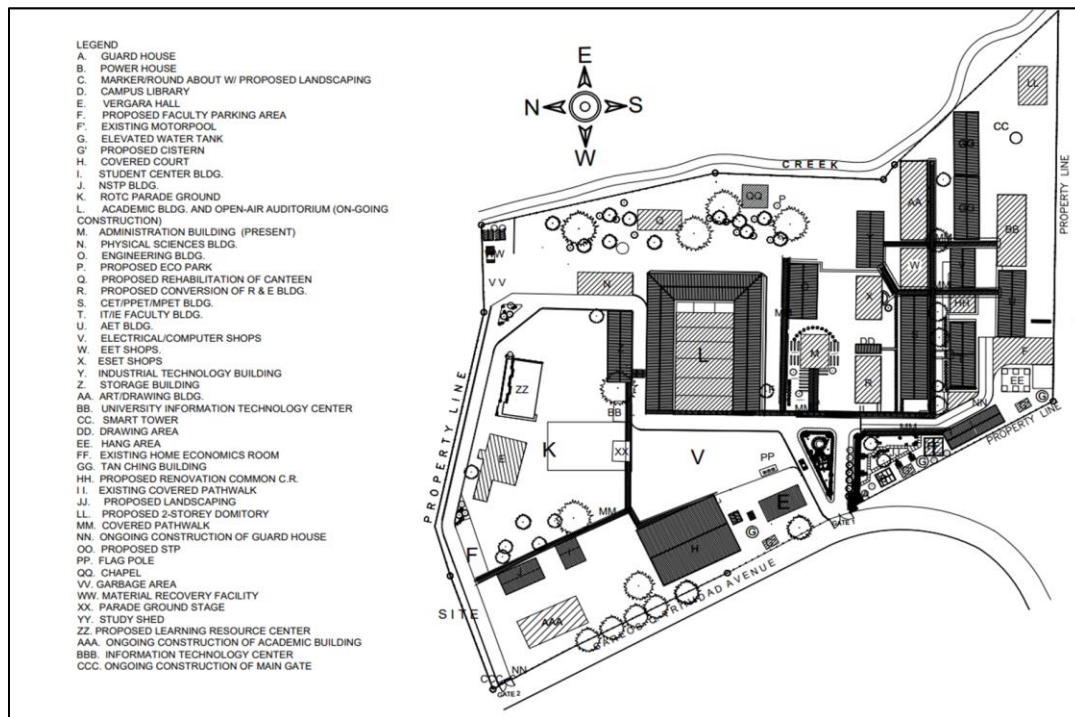

Figure 1 Site Development Plan

The 5-hectare land from which the campus facilities are planned is divided into six (6) zones, namely:

1. Academic zone;
2. Administrative zone;
3. Multipurpose activity zone;
4. Public zone;
5. Utility/service zone; and
6. Private area zone

Currently, the estimated land area utilized for existing facilities and newly constructed buildings is 17,292.60 square meters which comprises around 34% of the total area. There are two (2) on-going projects for this year and five (5) project proposals with land share of 5.51% and 2.97%, respectively (see figure 2). Therefore, it is evident that in the years to come, land use will increase to around 42% (an increase of 8%). This 8% increase will somehow address the population of 14% estimated growth rate in Dasmariñas City for the next ten (10) years. Table 1 below shows the details of the estimated land area use and percentage share from the total area by major buildings and other facilities in each zone.

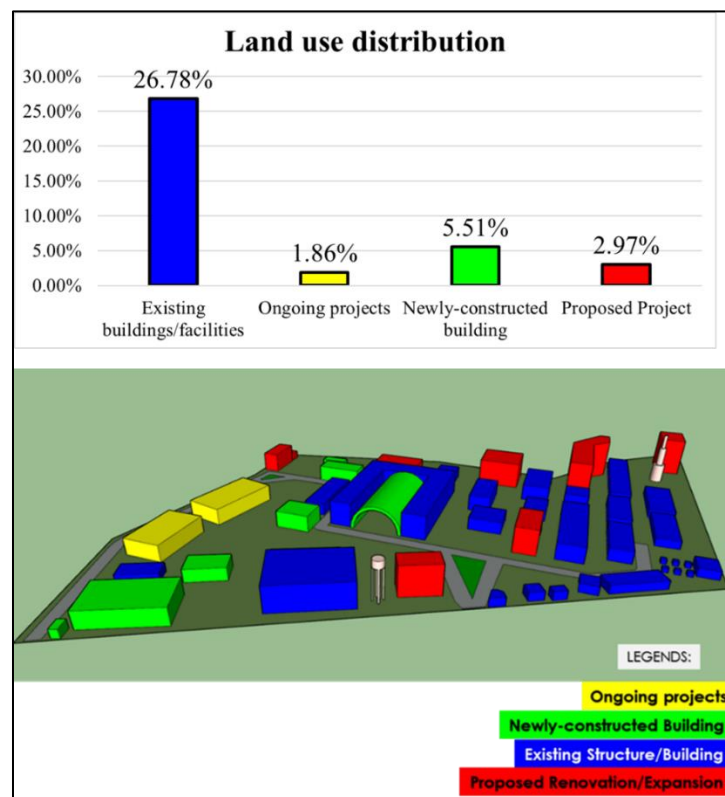

Figure 2 Summary of land use distribution for existing and proposed projects

Table 1

Existing Land Use by Zone

Name of Building/Structure	Land area (square meter)	Land use percent distribution
Academic zone		
NSTP/ROTC Building	271.395	0.53%
Academic Building	1,058.40	2.08%
Engineering Building	129.51	0.25%
R&E Building	527.06	1.03%
CET/PPET/MPET Building	424.08	0.83%
IT/IE Faculty Building	400	0.78%
AET Building	235.87	0.46%
EET/ESET Building	407.58	0.80%
EET Building	407.58	0.80%
ESET Building	151.93	0.30%
2-Storey 4-Classroom	134.96	0.26%
2-Storey 6-Classroom Building	171.625	0.34%
ART/Drawing Building	1,274.24	2.50%
Welding Shop	178.5	0.35%
4-Classroom Building	203.68	0.40%
Physics and Chemistry	400	0.78%
Academic Building	687.6	1.35%
Two-storey Learning Resource Center	403	0.79%
Total (Academic zone)	7,467.01	14.63%
Administrative zone		
SDWS Bldg.	182.45	0.36%
Administration Building	323.58	0.63%
Administrative Building (Newly-constructed)	546.91	1.07%
Total (Administrative zone)	1,052.94	2.06%
Multipurpose activity zone		
Covered Court	1,105.45	2.17%
Student Center Building	174.66	0.34%
ROTC Parade Ground	125	0.25%
Open Amphitheater	1,296.00	2.54%
Cooperative Store	15	0.03%
Infotech Building	203.64	0.40%
Information Technology Building	150	0.29%
New gate 1	25	0.05%
Total (Multipurpose activity zone)	3,094.75	6.07%
Public zone		
Marker/Round About	200	0.39%
Covered Pathwalk	450	0.88%
Parking Area	750	1.47%
Proposed New Chapel with Landscapes	50	0.10%
Food Court	350	0.69%

Name of Building/Structure	Land area (square meter)	Land use percent distribution
Drawing Area	25	0.05%
Hang Area	100	0.20%
Common C.R.	162.63	0.32%
Comfort Room for Male and Female	50	0.10%
Flag Pole	50	0.10%
Main Road	3,000.00	5.88%
Total (Public zone)	5,187.63	10.17%
Utility/service zone		
Guard House	15	0.03%
Power House	225.27	0.44%
Elevated Water Tank	75	0.15%
material recovery facility (MRF)	75	0.15%
Total (Utility/service zone)	390.27	0.77%
Private area zone	0.77%	
Smart Tower	100	0.20%
Total (Private area zone)	100	0.20%
Grand total land use	17,292.60	33.91%

III. The Academic Zone of the Campus

The Academic zone is the largest zone in the site which has a total land use area of 7,467.01 square meter or a land share distribution of almost 15% of the total land area and that around 43% of the existing total land use. This zone consists of teaching facilities used for the conduct of classes in both lecture and laboratory, faculty rooms, office for assistant directors, learning resource center, and research and extension facilities. Presently, this zone consists of the existing buildings and rooms enumerated in Table 1. An additional land area of 361.40 square meters or 0.71% land area distribution will be utilized for the proposed construction of IT building and research center. Figure 3 highlights this zone from the development plan.

Table 2 shows the inventory of existing buildings, facilities and other infrastructure within the compound or areas occupied by the campus. This table also indicates the actual purpose or use of the structure.

Table 2

Inventory of Facilities in Academic Zone

No.	Name of Building/Structure	No. of Classrooms/ Room	Actual use of the facility/structure
1	NSTP/ROTC Building	2	This building houses the office for ROTC personnel.
2	Academic Building	32	Currently, this building serves as lecture and laboratory rooms for the departments of math and science and liberal arts. It also houses the

No.	Name of Building/Structure	No. of Classrooms/ Room	Actual use of the facility/structure
			office of procurement, supply, planning, alumni and project management committee.
3	Engineering Building	4	This facility provides engineering students and teachers lecture rooms, shop work rooms, and faculty room.
4	R&E Building	4	This facility houses the offices for research and extension, accreditation, gender and development, and infrastructure development.
5	CET/PPET/MPET Building	3	A dedicated building for the conduct of shop work for civil, power plant and mechanical curricular programs.
6	IT/IE Faculty Building	2	This building serves as faculty rooms for the departments of industrial education and industrial technology.
7	AET Building	2	A dedicated building for the conduct of lecture and shop work for automotive engineering technology.
8	EET/ESET Building	2	A secondary building for the conduct of lecture and shop work for electrical and electronics engineering technology.
9	EET Building	2	A dedicated building for the conduct of lecture and shop work for electrical engineering technology.
10	ESET Building	2	A dedicated building for the conduct of lecture and shop work for electronics engineering technology.
11	2-Storey 4-Classroom	4	This building serves as lecture and instrumentation rooms for industrial technology courses.
12	2-Storey 6-Classroom Building	6	This building provides rooms for research projects and utility rooms.
13	ART/Drawing Building	4	A dedicated building for the conduct of lecture and shop work for architecture technology.
14	Welding Shop	1	Welding shop work
15	4-Classroom Building	4	Lecture room for SHS
16	Physics and Chemistry Building	4	Conduct physics and chemistry experiments
17	Academic Building	14	This building provides the campus additional facility for classroom instruction, central offices for transactions, audio-visual and conference rooms as amenities.
18	Two-storey Learning Resource Center	18	Once completed, this new facility will provide library users with more efficient and conducive way of gathering information that will satisfy their academic needs. It also includes a separate

No.	Name of Building/Structure	No. of Classrooms/ Room	Actual use of the facility/structure
			room for thesis section and reference section, space for speech laboratory, computers, audio-visual room and exhibit rooms.
19	Proposed IT Building	NA	Proposed project
20	Proposed Research center	NA	Proposed project

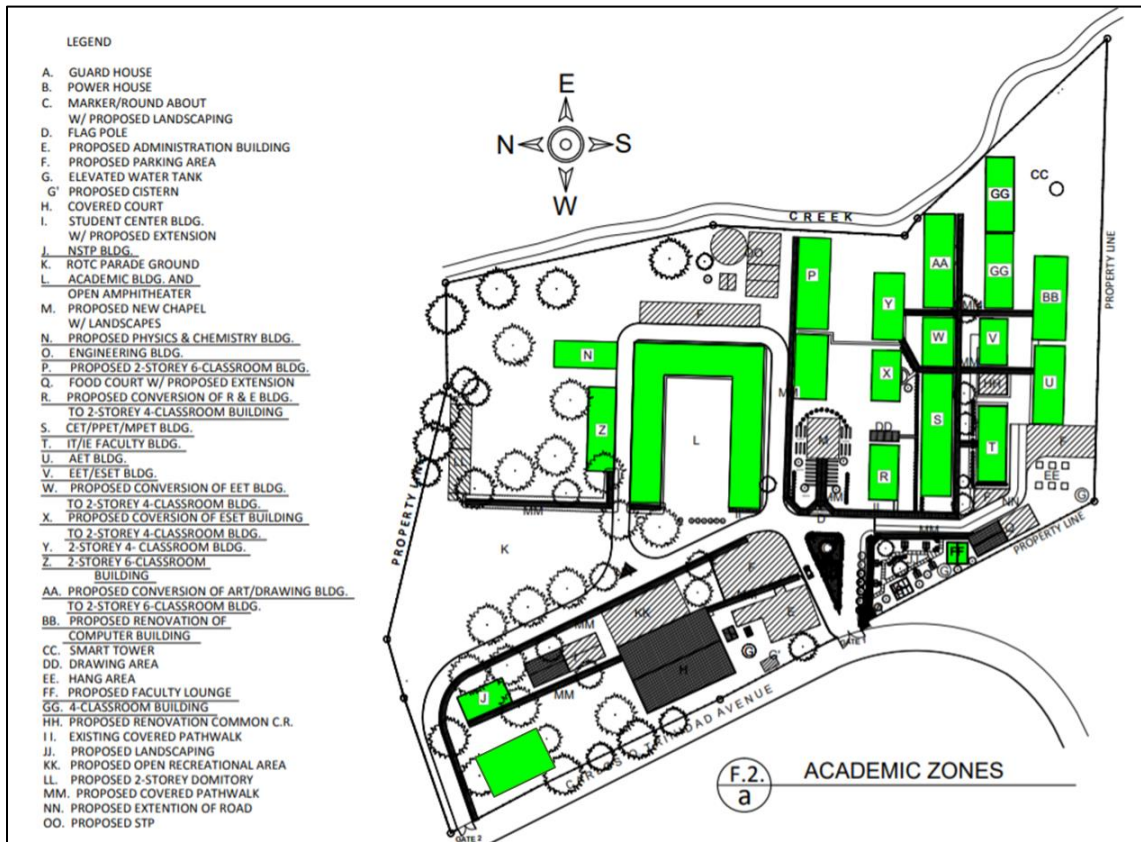

Figure 3 Development Plan for Academic Zone

IV. Current Building for Engineering Program

Figure 4 shows the 2-storey building for the engineering program. It has a total of 129.51 square meters and 259.02 land area and floor areas, respectively. It has 4 classrooms. It also houses the essential equipment for the various courses of the program.



Figure 4 Current Engineering Building

V. The Engineering Program

Currently, the TUP-Cavite Campus is offering 3 Engineering programs: Civil Engineering, Mechanical Engineering, and Electrical Engineering. Courses will be taken by students at Cavite Campus from 1st year to 3rd year and on the fourth year of the program, they will transfer to TUP-Manila to take the remaining courses.

Table 3 shows the current and projected population of engineering students in the future. During the first semester of school year 2021-2022, the engineering program had a total of 383 students. It is expected that there will be an additional 40 students per program if the four-year straight engineering program is implemented in the future as the campus has already applied for Certificate of Program Compliance by CHED. This is a projection of 503 total student population. This is likely to increase in the coming years due to the continued increase in the population in the Philippines. As of 2021, the annual

growth rate in the Municipality of Dasmarinas is 1.37%. If we assume an annual growth rate to be constant for the next 10 years, it can also be assumed that the population of students in the same period will also increase at this rate. To commensurate with this growth rate, the population of students will increase by 13.7% for the next 10 years and the total student engineering program is expected to be 572.

Table 3

Current and Projected Population of Engineering Students

Program	Enrollment Data (1st Sem SY 2021-2022)	Project enrollment for complete engineering program	Projected enrollment for the next 10 years
Bachelor of Science in Civil Engineering (BSCE)	136	176	200
Bachelor of Science in Electrical Engineering (BSEE)	114	154	175
Bachelor of Science in Mechanical Engineering (BSME)	133	173	197
Total	383	503	572

VI. Features and Capacities of the Proposed Building

Figure 5 shows the perspective of the six-storey building. The building consists of various features such as lecture room, laboratory rooms to house lab equipment, CAD rooms, multi-purpose hall, offices, conference room, multi-media center, and E-library (see figures 6 to 9). These are in accordance with the instructional facilities stated in section 2.4 of CMO 86, series 2017. Once operationalized, this building will significantly contribute for the accommodation of projected 13.7% increase in population of students for the next 10 years especially when the complete engineering program has been implemented and it will also support the plan to offer architecture program.



Figure 5 Proposed Engineering and Architecture Building

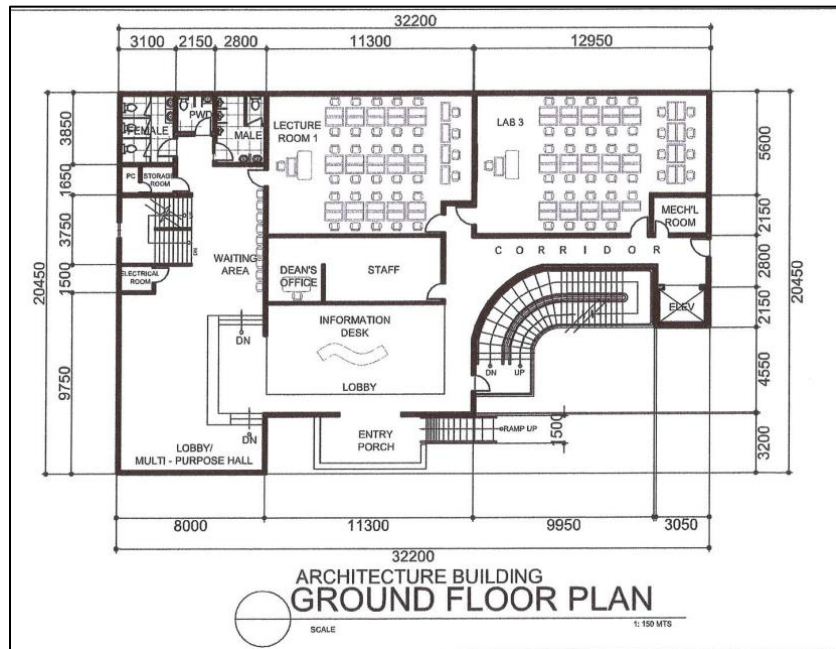

Figure 6 Ground Floor Plan

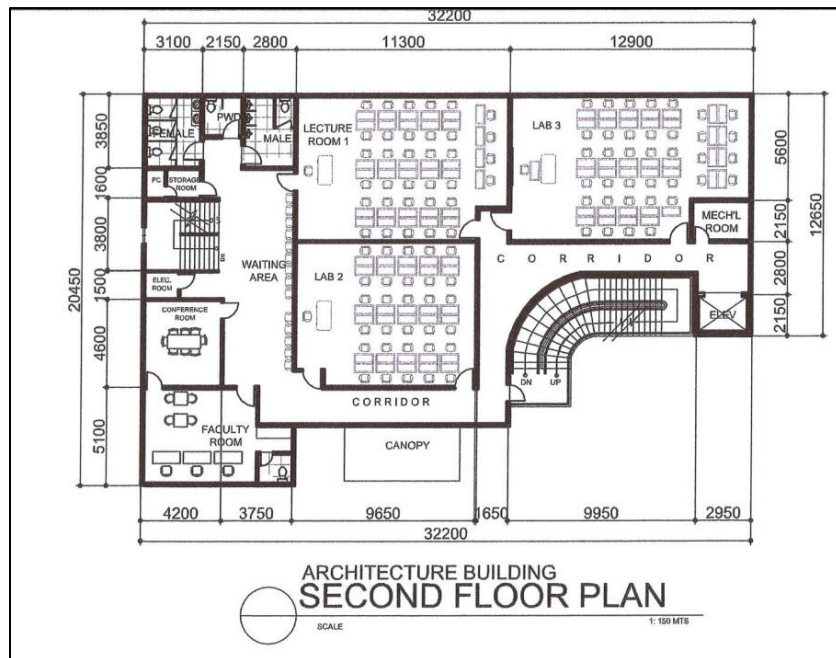

Figure 7 Second Floor Plan

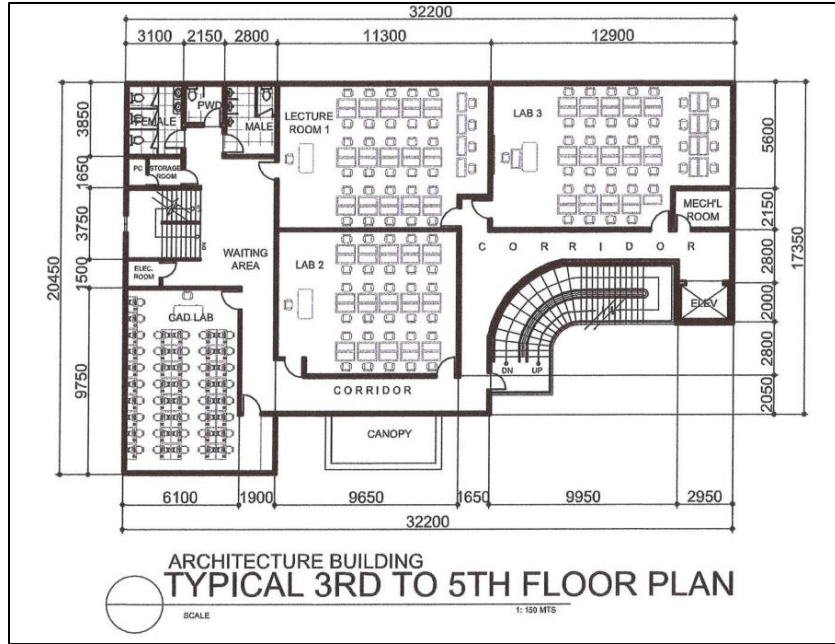

Figure 8 Typical Third to Fifth Floor Plan

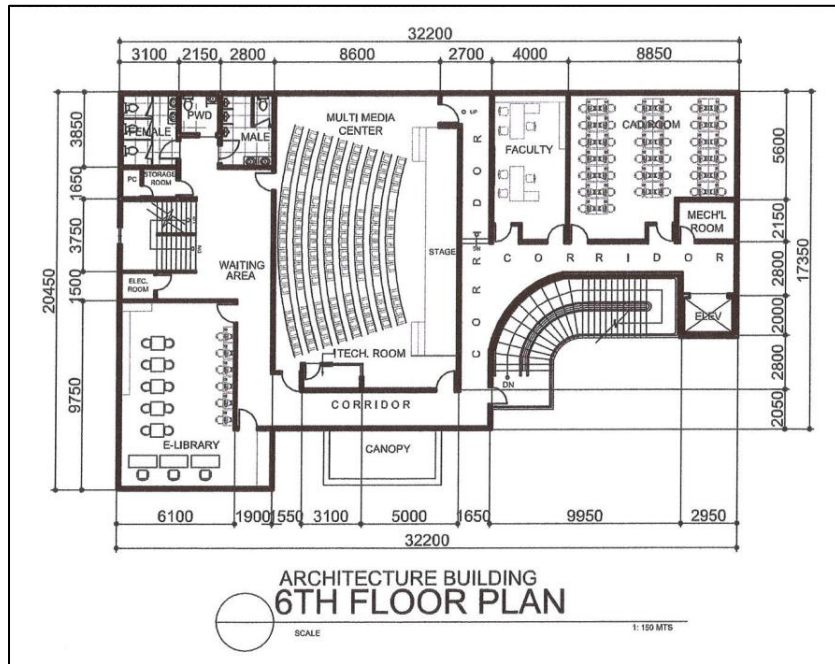

Figure 9 Sixth Floor Plan

Furthermore, based on table 4 shown below, the total floor area of 1,248.49 square meter indicate that the building can accommodate more than 1,000 students at the same time considering the minimum standard of 1 square meter of floor area per student set by the National Building Code (P.D. 1096). Therefore, this will ensure that the projected 572 engineering students will have a pleasant facility to support their studies.

Table 4
Floor area of classrooms and laboratory rooms

Location Plan	Room	Floor Area (in sq. meter)
Ground floor	Lecture room 1	87.58
	Lab room 2	100.36
Second floor	Lecture room 1	87.58
	Lab room 2	100.36
	Lab room 3	77.20
Third floor	Lecture room 1	87.58
	Lab room 2	100.36
	Lab room 3	77.20
Fourth floor	Lecture room 1	87.58
	Lab room 2	100.36
	Lab room 3	77.20
Fifth floor	Lecture room 1	87.58
	Lab room 2	100.36
	Lab room 3	77.20
Total		1,248.49

References

CMO No. 86 s. 2017
TUPC Bulletin of Information
National Building Code
LUDIP of TUPC



DETAILED ENGINEERING DESIGN OF ARCHITECTURE AND ENGINEERING BUILDING AT TUP CAVITE (PHASE I)



P E R S P E C T I V E

CONSTRUCTION OF PROPOSED ARCHITECTURE AND ENGINEERING BLDG

THE SITE

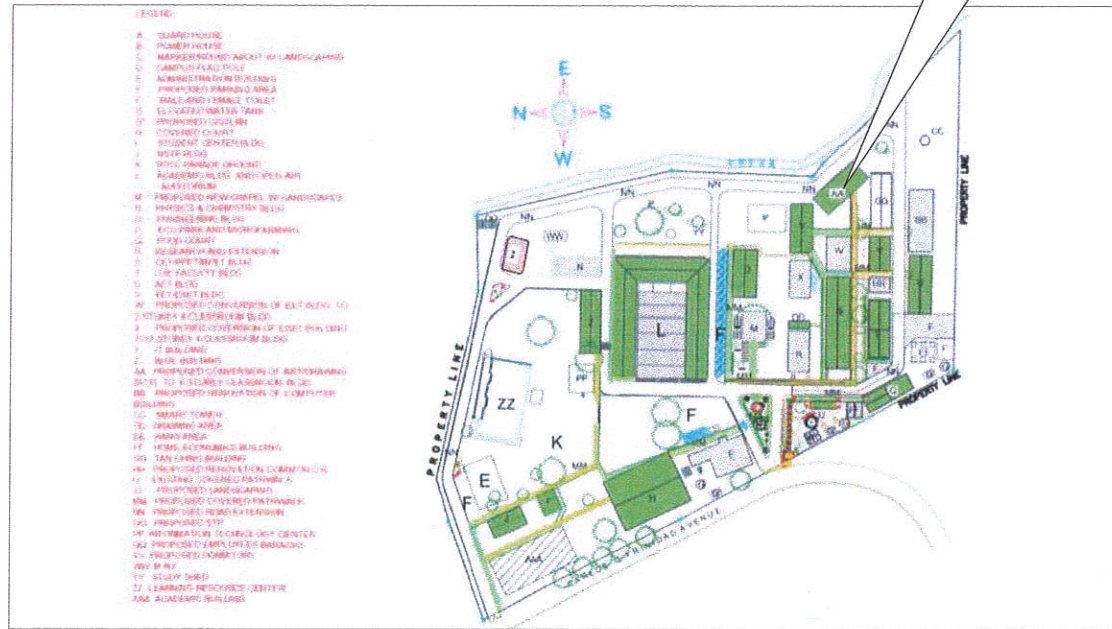

2 SITE DEVELOPMENT PLAN/KEY PLAN
A-1 SCALE 1:1000

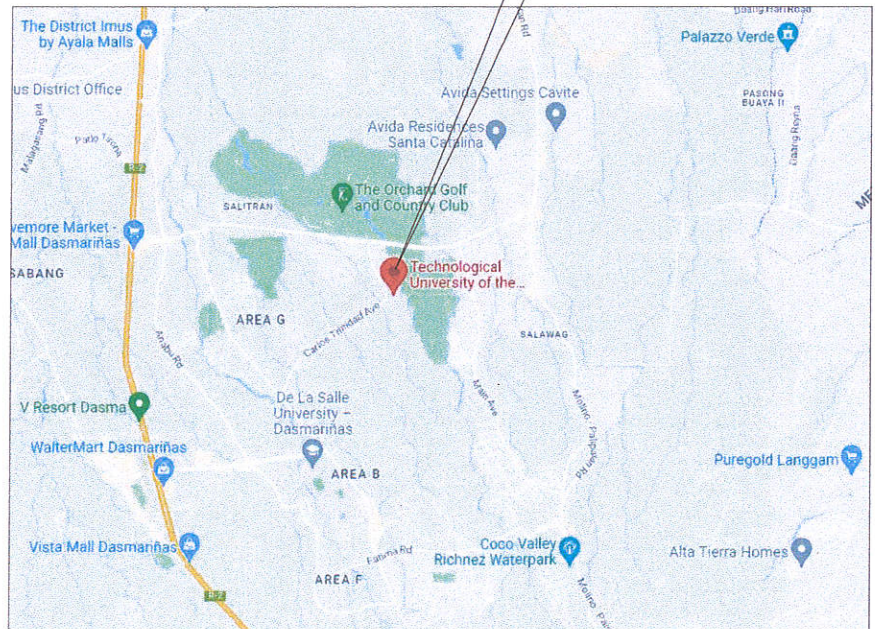

3 VICINITY MAP
A-1 SCALE NTS

TABLE OF CONTENTS

ARCHITECTURAL

- (A-1) PERSPECTIVE VIEW, VICINITY MAP, SITE DEVELOPMENT PLAN & TABLE OF CONTENTS
- (A-2) GROUND FLOOR PLAN
- (A-3) SECOND FLOOR PLAN
- (A-4) TYPICAL THIRD TO FIFTH FLOOR PLAN
- (A-5) 6TH FLOOR PLAN
- (A-6) FRONT ELEVATION
- (A-7) RIGHT-SIDE ELEVATION
- (A-8) LEFT-SIDE ELEVATION
- (A-9) REAR ELEVATION
- (A-10) SCHEDULE OF DOORS AND WINDOWS, RAMP PLAN, HANDRAIL SPOT DETAIL, RAMP DETAIL SECTION, HANDRAIL SECTION
- (A-11) TOILET DETAIL
- (A-12) TOILET DETAIL
- (A-13) TOILET DETAIL

STRUCTURAL

PLUMBING

ELECTRICAL

MECHANICAL

REPUBLIC OF THE PHILIPPINES TUPC TECHNOLOGICAL UNIVERSITY OF THE PHILIPPINES - CAVITE CAMPUS
DISTRICT / CITY / MUNICIPALITY
LAND USE AND ZONING
LINE AND GRADE
ARCHITECTURAL
STRUCTURAL
PLUMBING
SANITARY
ELECTRICAL
ELECTRONICS
MECHANICAL

<p>TUP CAVITE</p>	OWNER	ARCHITECT/ENGINEER	DRAWN BY:	PROJECT TITLE	SHEET CONTENT	SHEET NO.
	TECHNOLOGICAL UNIVERSITY OF THE PHILIPPINES CAVITE CAMPUS			PROPOSED ENGINEERING AND ARCHITECTURE BUILDING	PERSPECTIVE VICINITY MAP SITE DEVELOPMENT PLAN	A
	REG NO:	DATE ISSUED:	REV NO:	DATE:	LOCATION: CQT. AVE. BRGY. SALAWAG, DASMARIÑAS CITY, CAVITE, PHILIPPINES.	1
	DATE EXPIRED:	PLACE ISSUED:				
	PTR NO:	TIN NO:				

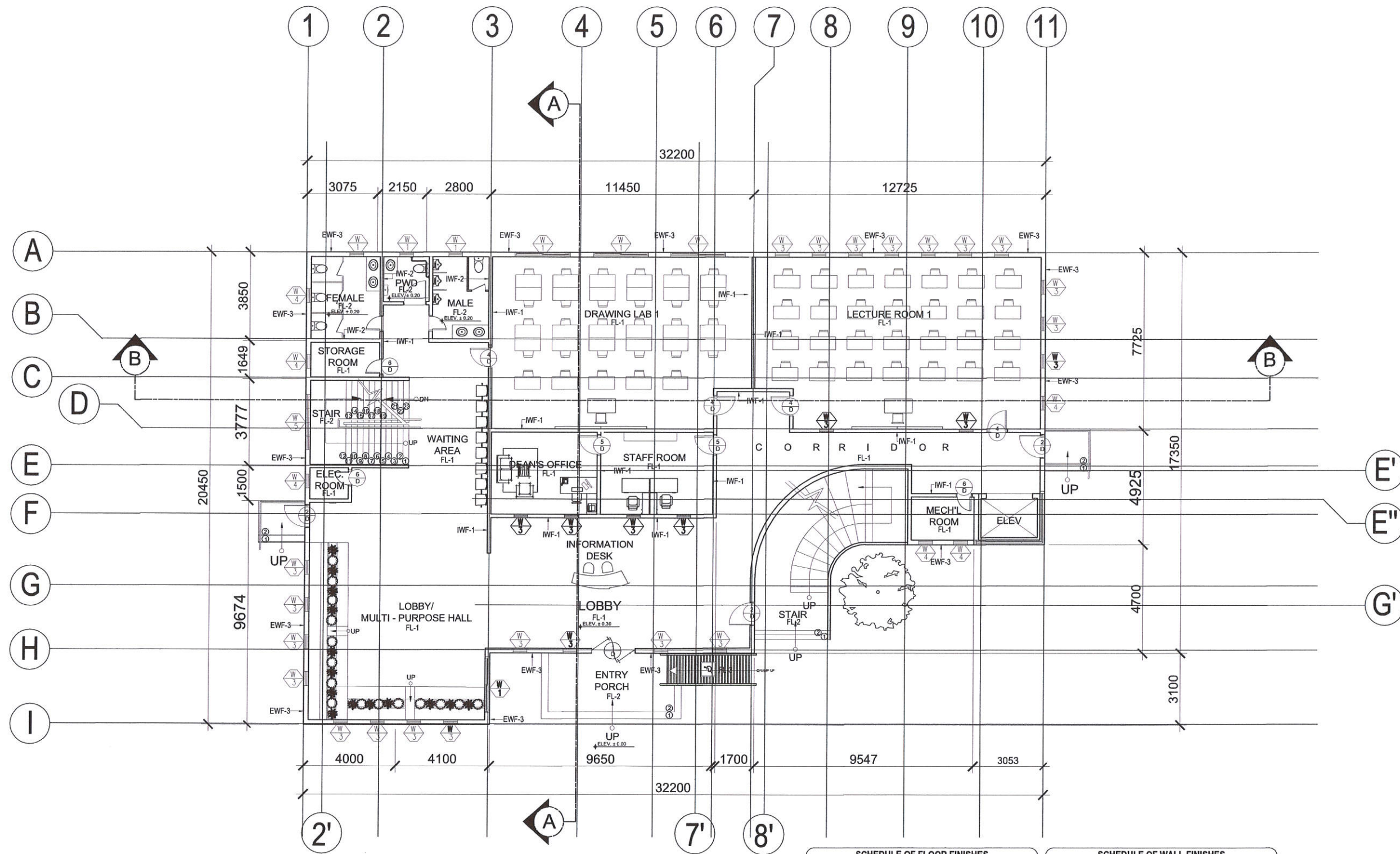

1
A-3
ENGINEERING AND ARCHITECTURE BUILDING
GROUND FLOOR PLAN
SCALE 1:100 M

SCHEDULE OF FLOOR FINISHES	
FL-1	600 X 600 mm GLAZED TILE FLOOR FINISH OR APPROVED EQUAL (SUBMIT SAMPLE FOR APPROVAL)
FL-2	600 X 600 mm TEXTURED UNGLAZED TILES FLOOR FINISH (SIZE AND/OR COLOR FOR APPROVAL BY END-USER)
FL-3	NON-SKID CEMENT FLOOR FINISH WITH 6mm GROOVE LINES AT 20mm O.C.

SCHEDULE OF WALL FINISHES	
IWF-1	150 mm THK. CHB INTERIOR WALL WITH PLAIN CEMENT PLASTER PAINTED FINISH
IWF-2	200 X 300 mm VITRIFIED GLAZED TILE WALL FINISH - TYPICAL ON ALL TOILET WALLS
EWF-3	200 mm THK. CHB EXTERIOR WALL WITH PLAIN CEMENT PLASTER PAINTED FINISH

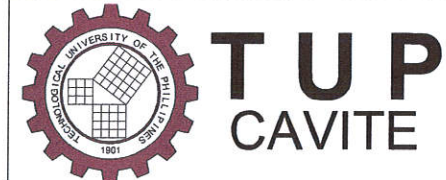

OWNER
TECHNOLOGICAL UNIVERSITY OF THE PHILIPPINES
CAVITE CAMPUS

ARCHITECT/ENGINEER
REG NO: _____ DATE ISSUED: _____
DATE EXPIRED: _____ PLACE ISSUED: _____
PTR NO: _____ TIN NO: _____

DRAWN BY: _____ PROJECT TITLE
PROPOSED ENGINEERING AND ARCHITECTURE BUILDING
LOCATION: CQT. AVE. BRGY. SALAWAG, DASMARIÑAS CITY, CAVITE, PHILIPPINES.

SHEET CONTENT
GROUND FLOOR PLAN
SHEET NO.
A
2

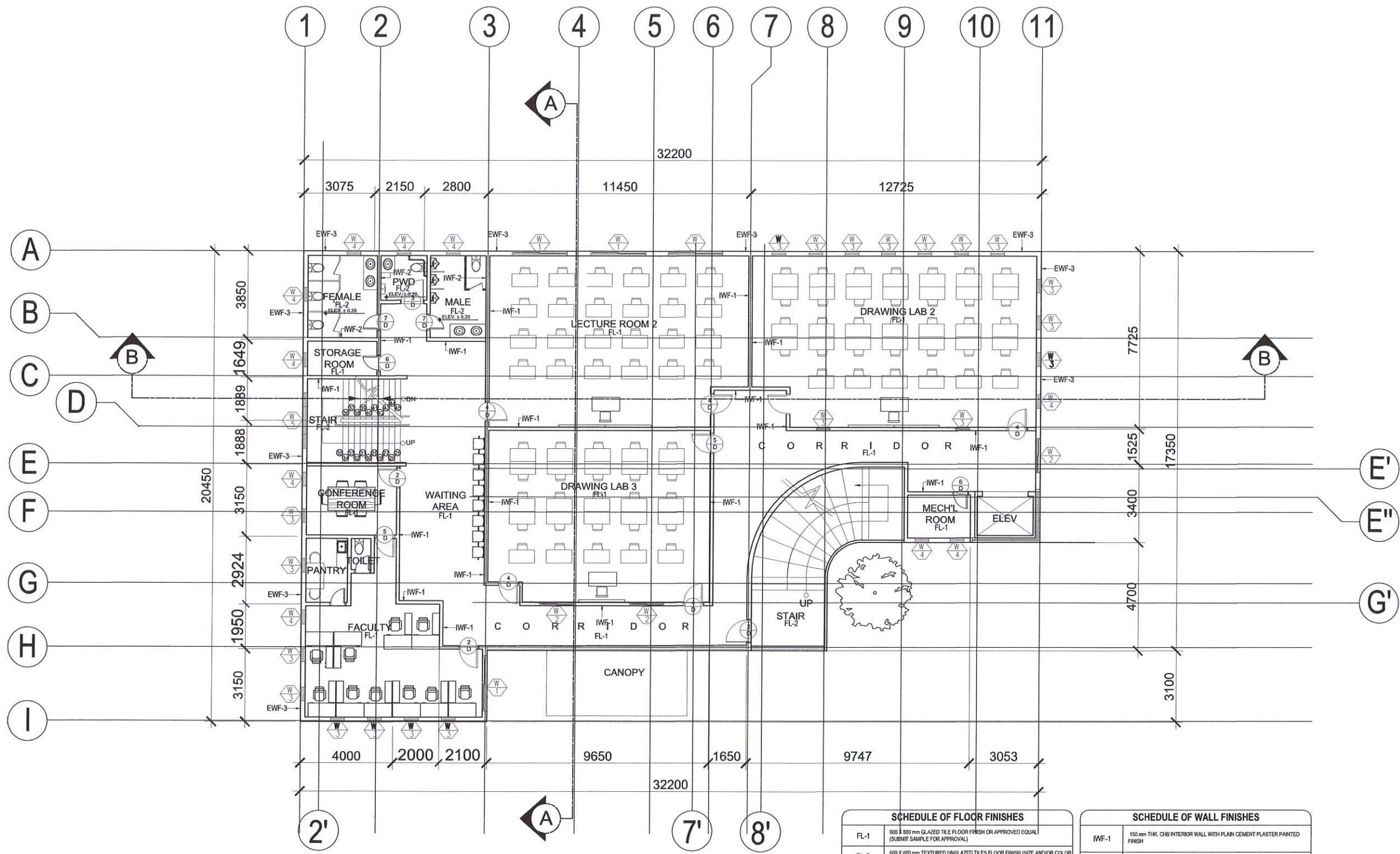

1
A-3
ENGINEERING AND ARCHITECTURE BUILDING
SECOND FLOOR PLAN
SCALE 1:100 M

SCHEDULE OF FLOOR FINISHES	
FL-1	600 X 600 mm GLAZED TILE FLOOR FINISH OR APPROVED EQUAL (SUBMIT SAMPLE FOR APPROVAL)
FL-2	600 X 600 mm TEXTURED UNGLAZED TILES FLOOR FINISH (SIZE AND/OR COLOR FOR APPROVAL BY END-USER)
FL-3	NON-SKD CEMENT FLOOR FINISH WITH 6mm GROOVE LINES AT 20mm O.C.

SCHEDULE OF WALL FINISHES	
IWF-1	150 mm THK. CHB INTERIOR WALL WITH PLAIN CEMENT PLASTER PAINTED FINISH
IWF-2	200 X 300 mm VITRIFIED GLAZED TILE WALL FINISH - TYPICAL ON ALL TOILET WALLS
EWF-3	200 mm THK. CHB EXTERIOR WALL WITH PLAIN CEMENT PLASTER PAINTED FINISH

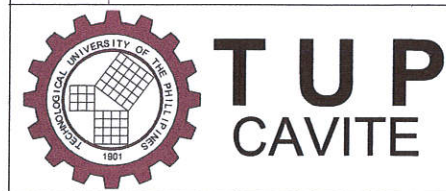

OWNER
TECHNOLOGICAL UNIVERSITY OF THE PHILIPPINES
CAVITE CAMPUS

ARCHITECT/ENGINEER
REG NO: _____ DATE ISSUED: _____
DATE EXPIRED: _____ PLACE ISSUED: _____
PTR NO: _____ TIN NO: _____

DRAWN BY: _____ PROJECT TITLE
PROPOSED ENGINEERING AND ARCHITECTURE BUILDING
LOCATION: CQT. AVE. BRGY. SALAWAG, DASMARIÑAS CITY, CAVITE, PHILIPPINES.

SHEET CONTENT
SECOND FLOOR PLAN
SHEET NO.
A
3

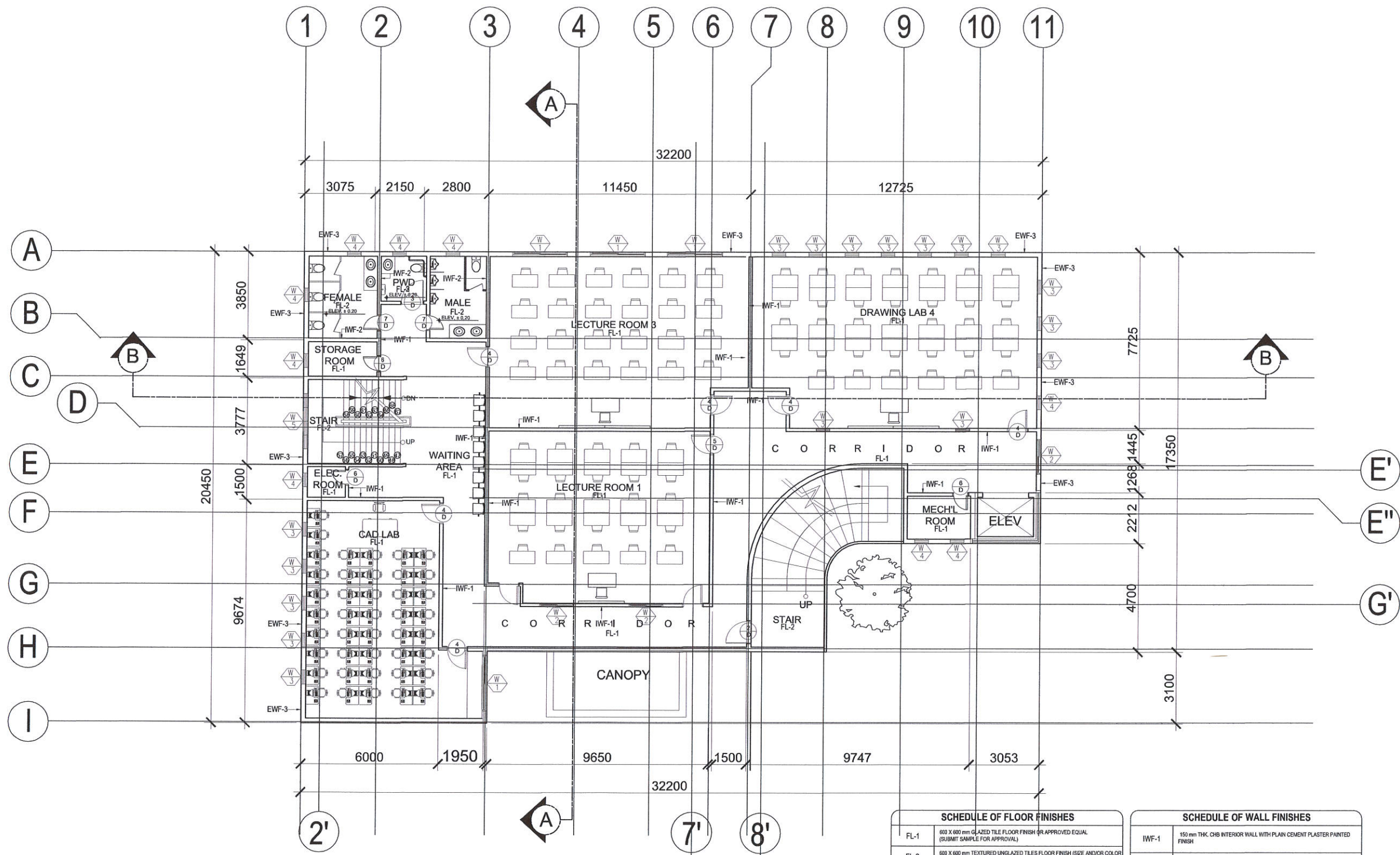

SCHEDULE OF FLOOR FINISHES	
FL-1	600 X 600 mm GLAZED TILE FLOOR FINISH OR APPROVED EQUAL (SUBMIT SAMPLE FOR APPROVAL)
FL-2	600 X 600 mm TEXTURED UNGLAZED TILES FLOOR FINISH (SIZE AND/OR COLOR FOR APPROVAL BY END-USER)
FL-3	NON-SKID CEMENT FLOOR FINISH WITH 6mm GROOVE LINES AT 20mm O.C.

SCHEDULE OF WALL FINISHES	
IWF-1	150 mm THK. CHB INTERIOR WALL WITH PLAIN CEMENT PLASTER PAINTED FINISH
IWF-2	200 X 300 mm VITRIFIED GLAZED TILE WALL FINISH - TYPICAL ON ALL TOILET WALLS
EW-3	200 mm THK. CHB EXTERIOR WALL WITH PLAIN CEMENT PLASTER PAINTED FINISH

1
A-3
ENGINEERING AND ARCHITECTURE BUILDING
TYPICAL 3RD TO 5TH FLOOR PLAN
SCALE 1:100

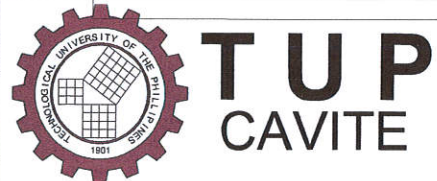

OWNER
TECHNOLOGICAL UNIVERSITY OF THE PHILIPPINES
CAVITE CAMPUS

ARCHITECT/ENGINEER

REG NO:	DATE ISSUED:	REV NO:	DATE:
DATE EXPIRED:	PLACE ISSUED:		
PTR NO:	TIN NO:		

DRAWN BY:

PROJECT TITLE
PROPOSED ENGINEERING AND ARCHITECTURE BUILDING

LOCATION: CQT. AVE. BRGY. SALAWAG, DASMARIÑAS CITY, CAVITE, PHILIPPINES.

SHEET CONTENT
TYPICAL 3RD TO 5TH FLOOR PLAN

SHEET NO.
A
4

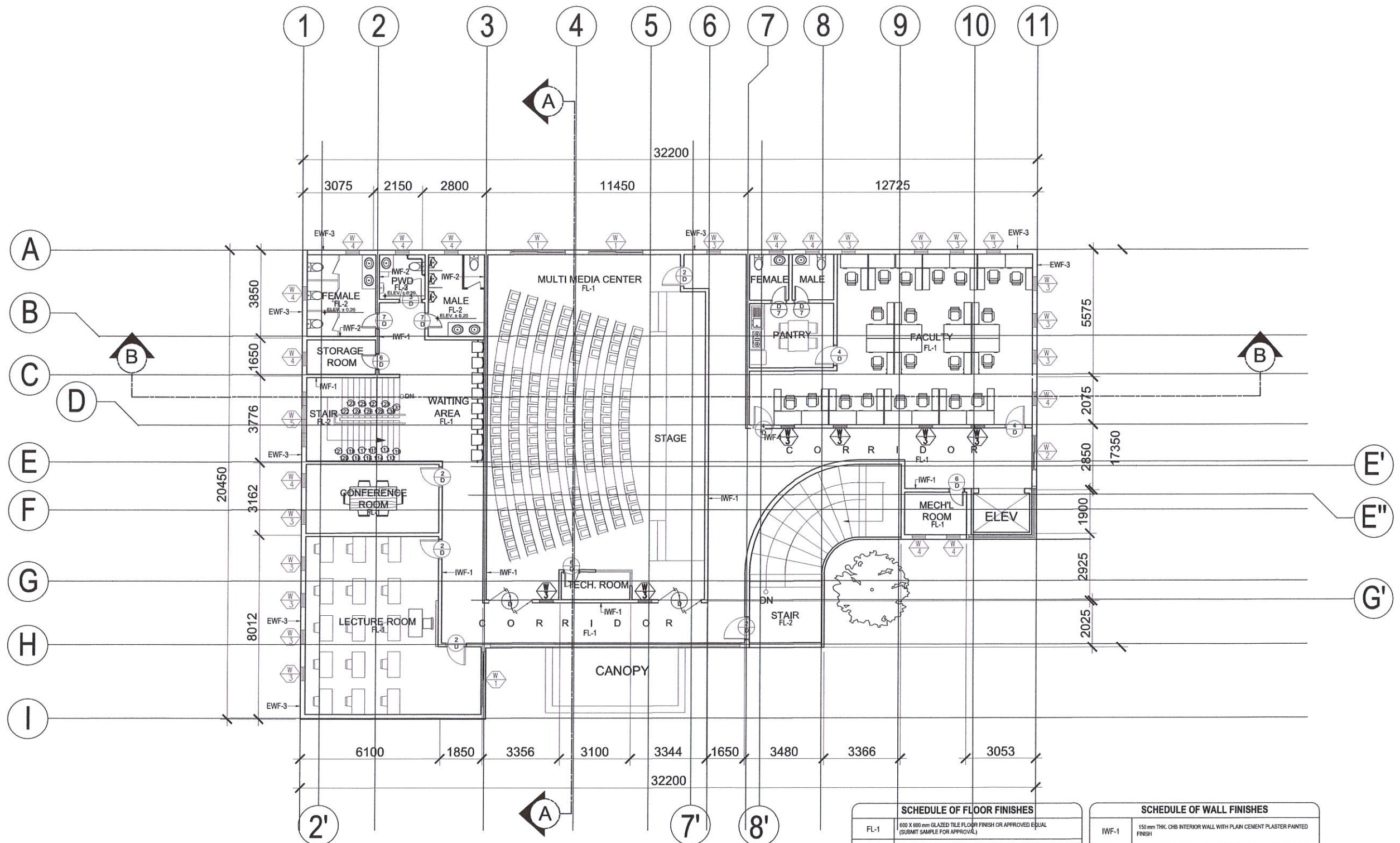

1
A-3
ENGINEERING AND ARCHITECTURE BUILDING
6TH FLOOR PLAN
SCALE 1:100 M

SCHEDULE OF FLOOR FINISHES	
FL-1	600 X 600 mm GLAZED TILE FLOOR FINISH OR APPROVED EQUAL (SUBMIT SAMPLE FOR APPROVAL)
FL-2	600 X 600 mm TEXTURED UNGLAZED TILES FLOOR FINISH (SIZE AND/OR COLOR FOR APPROVAL BY END-USER)
FL-3	NON-SKID CEMENT FLOOR FINISH WITH 6mm GROOVE LINES AT 20mm O.C.

SCHEDULE OF WALL FINISHES	
IWF-1	150mm THK. CHB INTERIOR WALL WITH PLAIN CEMENT PLASTER PAINTED FINISH
IWF-2	200 X 300 mm VITRIFIED GLAZED TILE WALL FINISH - TYPICAL ON ALL TOILET WALLS
EW-3	200mm THK. CHB EXTERIOR WALL WITH PLAIN CEMENT PLASTER PAINTED FINISH

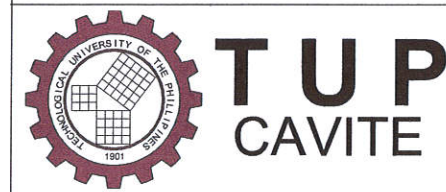

OWNER
TECHNOLOGICAL UNIVERSITY OF THE PHILIPPINES
CAVITE CAMPUS

ARCHITECT/ENGINEER

REG NO:	DATE ISSUED:	REV NO:	DATE:
DATE EXPIRED:	PLACE ISSUED:		
PTR NO:	TIN NO:		

DRAWN BY:

PROJECT TITLE
PROPOSED ENGINEERING AND ARCHITECTURE BUILDING

LOCATION: CQT. AVE. BRGY. SALAWAG, DASMARIÑAS CITY, CAVITE, PHILIPPINES.

SHEET CONTENT
6TH FLOOR PLAN

SHEET NO.
A
5

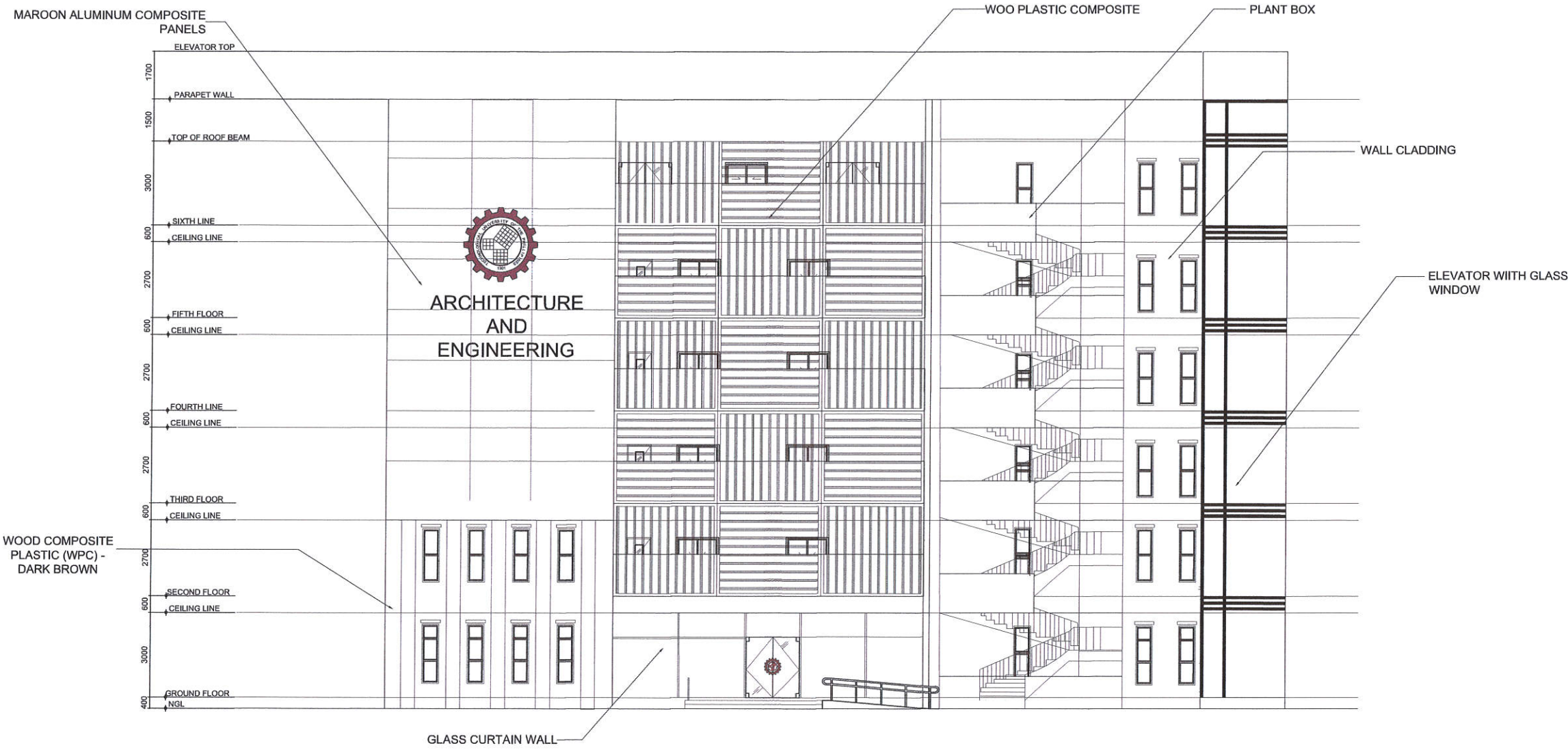

ENGINEERING AND ARCHITECTURE BUILDING
FRONT ELEVATION
 SCALE 1:100 M

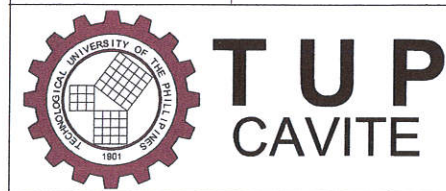

TUP
CAVITE
 OWNER
 TECHNOLOGICAL UNIVERSITY OF THE PHILIPPINES
 CAVITE CAMPUS

ARCHITECT/ENGINEER
 REG NO: _____ DATE ISSUED: _____
 DATE EXPIRED: _____ PLACE ISSUED: _____
 PTR NO: _____ TIN NO: _____

DRAWN BY: _____
 PROJECT TITLE
 PROPOSED ENGINEERING AND ARCHITECTURE BUILDING
 LOCATION: CQT. AVE. BRGY. SALAWAG, DASMARIÑAS CITY, CAVITE, PHILIPPINES.

SHEET CONTENT
 FRONT ELEVATION

SHEET NO.
A
6



ENGINEERING AND ARCHITECTURE BUILDING
RIGHT ELEVATION
 SCALE 1:100 M

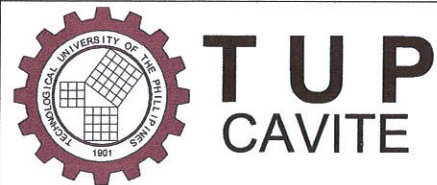

OWNER
 TECHNOLOGICAL UNIVERSITY OF THE PHILIPPINES
 CAVITE CAMPUS

ARCHITECT/ENGINEER

REG NO:	DATE ISSUED:	REV NO:	DATE:
DATE EXPIRED:	PLACE ISSUED:		
PTR NO:	TIN NO:		

DRAWN BY:

PROJECT TITLE
 PROPOSED ENGINEERING AND ARCHITECTURE BUILDING

LOCATION: CQT. AVE. BRGY. SALAWAG, DASMARIÑAS CITY, CAVITE, PHILIPPINES.

SHEET CONTENT
 RIGH-SIDE ELEVATION

SHEET NO.
 A
 7



ENGINEERING AND ARCHITECTURE BUILDING
REAR ELEVATION
 SCALE 1:100 M



TUP
 CAVITE

OWNER
 TECHNOLOGICAL UNIVERSITY OF THE PHILIPPINES
 CAVITE CAMPUS

ARCHITECT/ENGINEER
 REG NO: DATE ISSUED: REV NO: DATE:
 DATE EXPIRED: PLACE ISSUED:
 PTR NO: TIN NO:

DRAWN BY:

PROJECT TITLE
 PROPOSED ENGINEERING AND ARCHITECTURE BUILDING
 LOCATION: CQT. AVE. BRGY. SALAWAG, DASMARINAS CITY, CAVITE, PHILIPPINES.

SHEET CONTENT
 REAR ELEVATION

SHEET NO.
 A
 8

EMENT
E FINISH

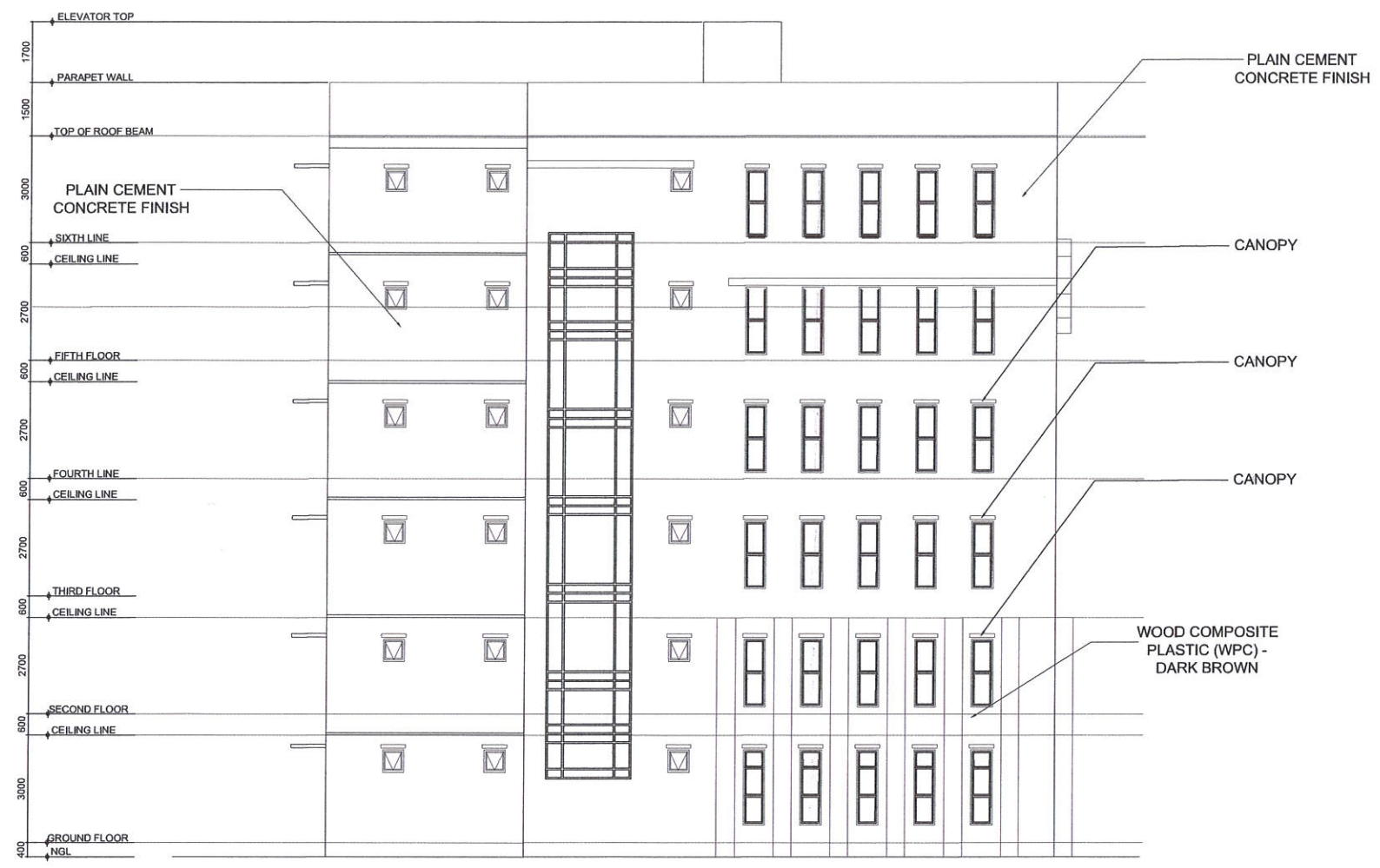

ENGINEERING AND ARCHITECTURE BUILDING
LEFT - SIDE ELEVATION
SCALE 1:100 M

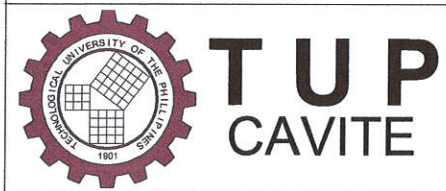

OWNER
TECHNOLOGICAL UNIVERSITY OF THE PHILIPPINES
CAVITE CAMPUS

ARCHITECT/ENGINEER
REG NO: _____ DATE ISSUED: _____
DATE EXPIRED: _____ PLACE ISSUED: _____
PTR NO: _____ TIN NO: _____

DRAWN BY: _____
PROJECT TITLE
PROPOSED ENGINEERING AND ARCHITECTURE BUILDING
LOCATION: CQT. AVE. BRGY. SALAWAG, DASMARIÑAS CITY, CAVITE, PHILIPPINES.

SHEET CONTENT
LEFT-SIDE ELEVATION

SHEET NO.
A
9

SLIDING WINDOW	SLIDING WINDOW	AWNING WINDOW	AWNING WINDOW				
28 SETS	15 SETS	102 SETS	42 SETS				
LOC: LOBBY, LECTURE ROOMS AND IN FRONT OF THE BUILDING							
GLASS DOOR OR APPROVED EQUAL SWING TYPE	GLASS DOOR OR APPROVED EQUAL SWING TYPE						
3 SETS	6 SETS	6 SETS	38 SETS	7 SETS	22 SETS	12 SETS	
LOC: ENTRY PORCH AND MULTI MEDIA CENTER	LOC: FIRE EXIT AND OUTSIDE STAIRWAYS	LOC: PWD TOILET	LOC: LECTURE ROOMS	LOC: FACULTY AND CONFERENCE ROOM	LOC: ENTRY PORCH AND MULTI MEDIA CENTER	LOC: STORAGE, ELECTRICAL, AND MECHANICAL ROOM	LOC: INDOOR STAIRWAYS

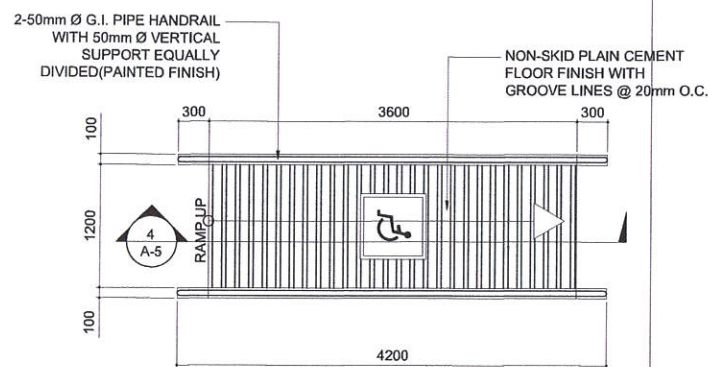

3 RAMP PLAN
SCALE 1:50 M

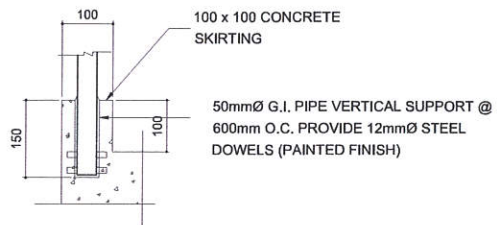

5 HANDRAIL SPOT DETAIL
SCALE 1:50 M

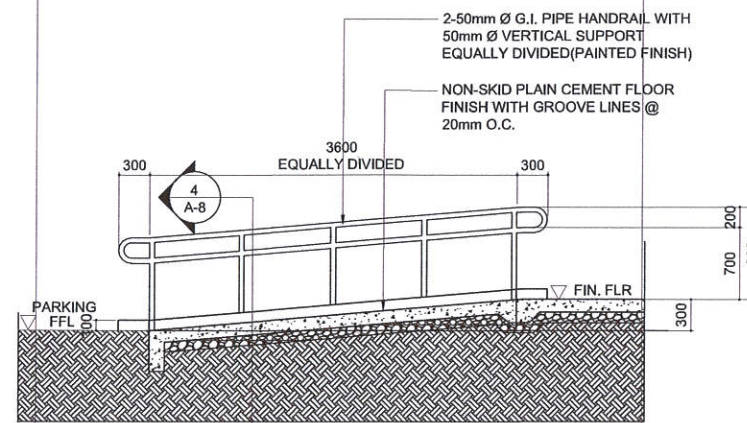

4 RAMP DETAIL SECTION
SCALE 1:50 M

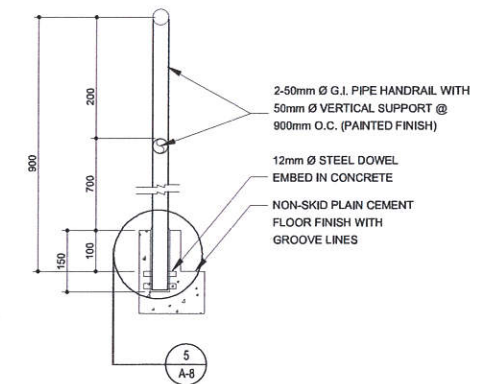

6 HANDRAIL SECTION
SCALE 1:50 M

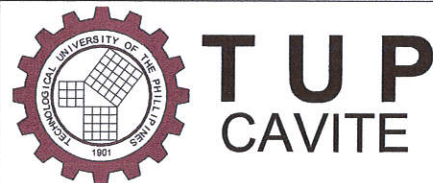

OWNER
TECHNOLOGICAL UNIVERSITY OF THE PHILIPPINES
CAVITE CAMPUS

ARCHITECT/ENGINEER

REG NO:	DATE ISSUED:	REV NO:	DATE:
DATE EXPIRED:	PLACE ISSUED:		
PTR NO:	TIN NO:		

DRAWN BY:
PROJECT TITLE
PROPOSED ENGINEERING AND ARCHITECTURE BUILDING
LOCATION: CQT. AVE. BRGY. SALAWAG, DASMARIÑAS CITY, CAVITE, PHILIPPINES.

SHEET CONTENT
SCHEDULE OF DOORS AND WINDOWS
RAMP PLAN
RAMP DETAIL SECTION
HANDRAIL SECTION

SHEET NO.
A
10

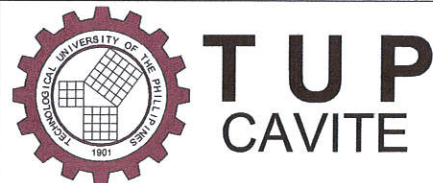
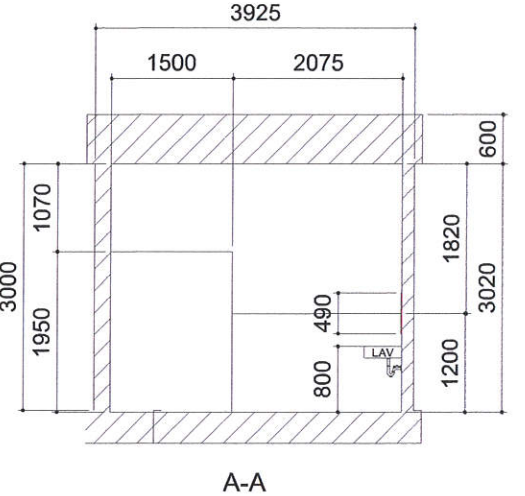
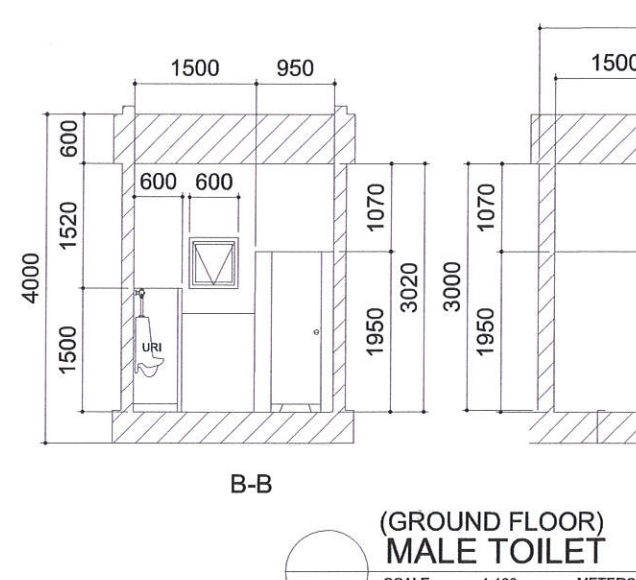
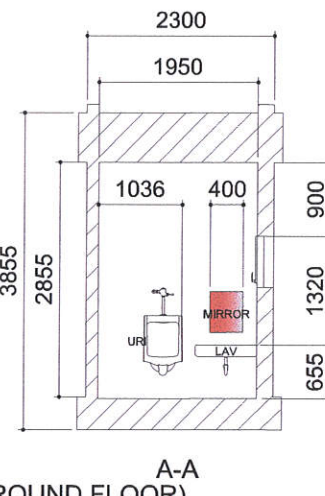
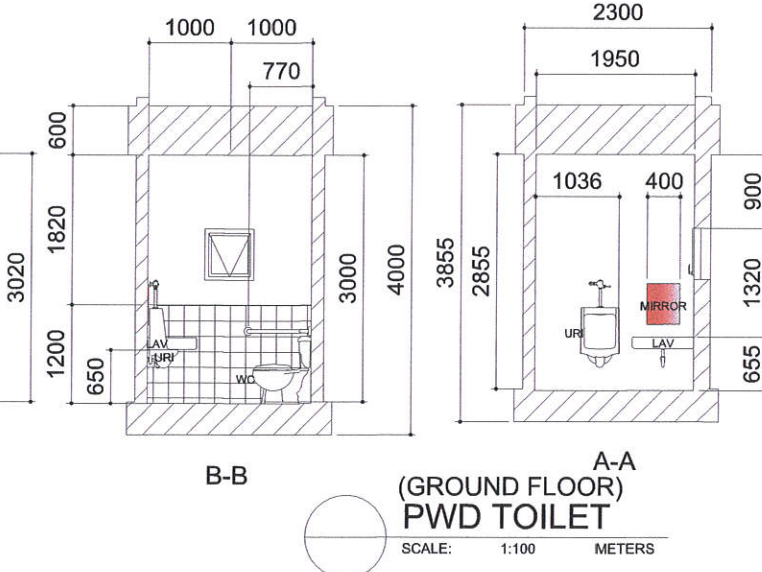
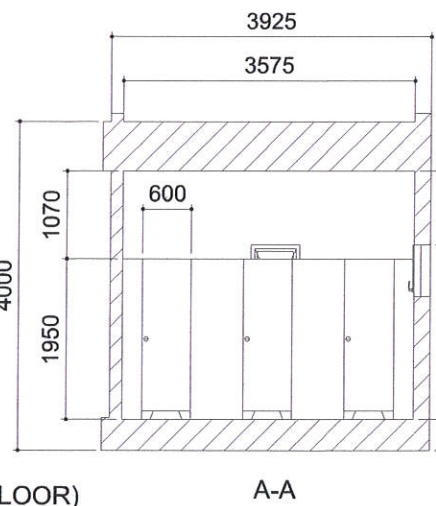
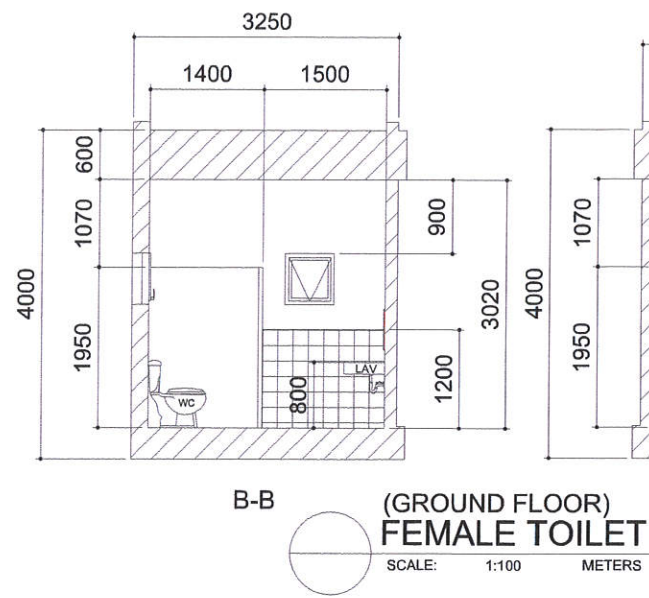
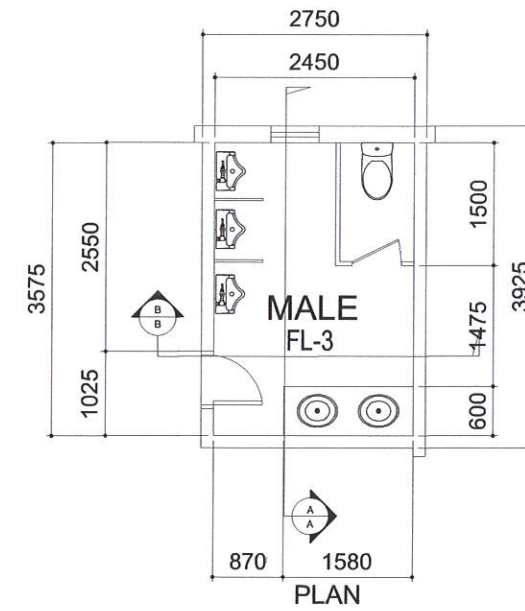
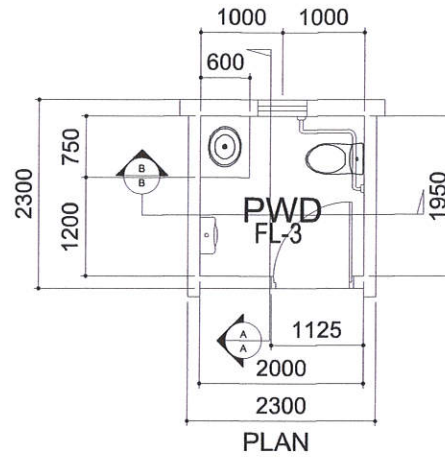
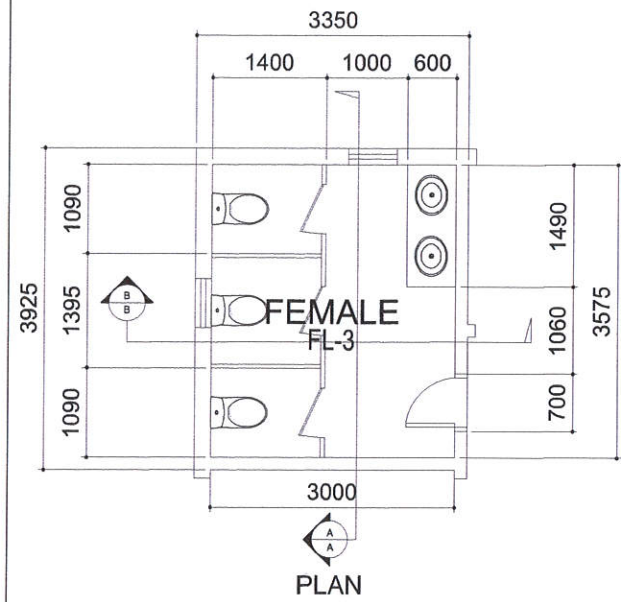

OWNER
TECHNOLOGICAL UNIVERSITY OF THE PHILIPPINES
CAVITE CAMPUS

ARCHITECT/ENGINEER

REG NO:	DATE ISSUED:	REV NO:	DATE:
DATE EXPIRED:	PLACE ISSUED:		
PTR NO:	TIN NO:		

DRAWN BY:

PROJECT TITLE
PROPOSED ENGINEERING AND ARCHITECTURE BUILDING

LOCATION: CQT. AVE. BRGY. SALAWAG, DASMARIÑAS CITY, CAVITE, PHILIPPINES.

SHEET CONTENT
TOILET DETAILS

SHEET NO.
A
11

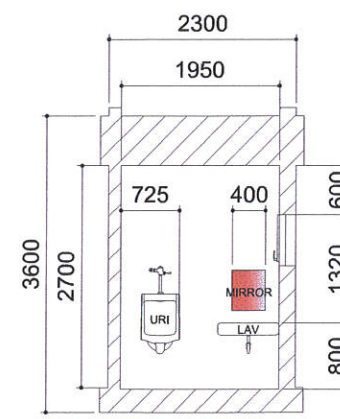
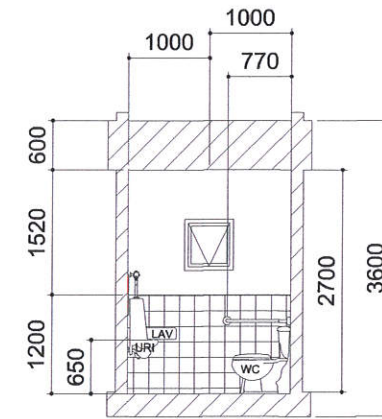
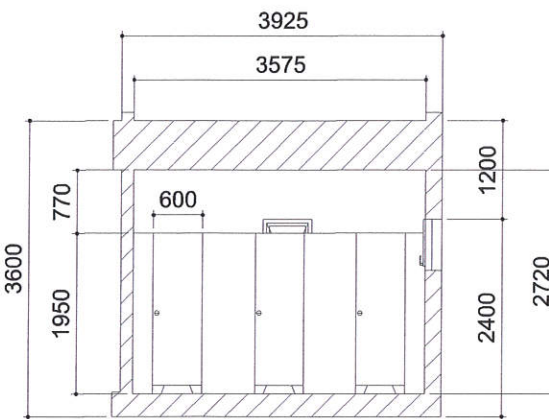
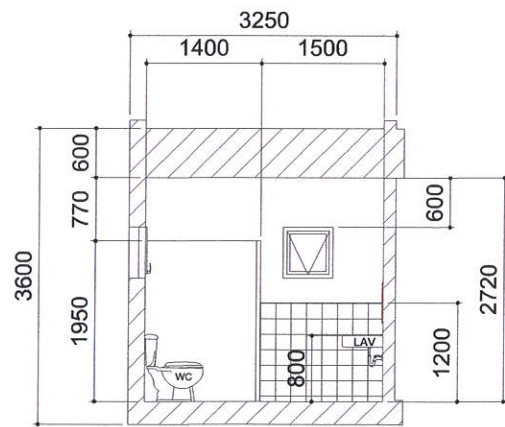
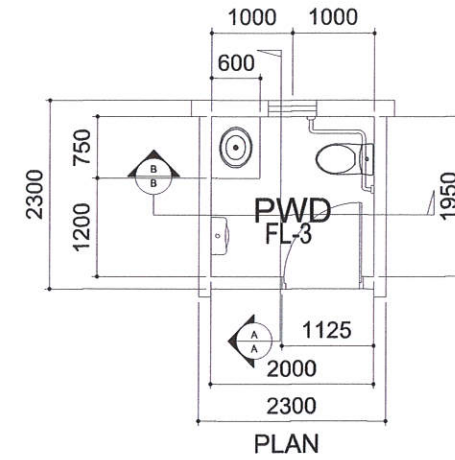
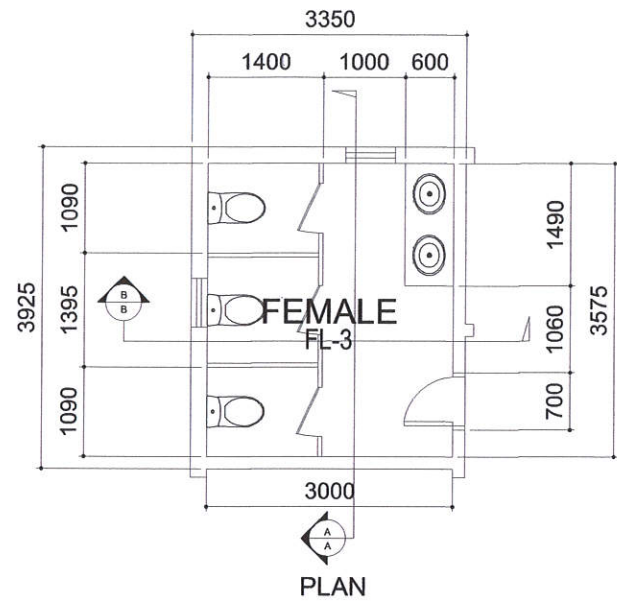

B-B
 (SECOND FLOOR)
FEMALE TOILET
 SCALE: 1:100 METERS

A-A

B-B
 (SECOND FLOOR)
PWD TOILET
 SCALE: 1:100 METERS

A-A

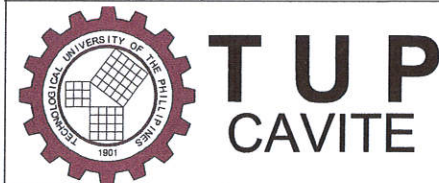

OWNER
 TECHNOLOGICAL UNIVERSITY OF THE PHILIPPINES
 CAVITE CAMPUS

ARCHITECT/ENGINEER

REG NO:	DATE ISSUED:	REV NO:	DATE:
DATE EXPIRED:	PLACE ISSUED:		
PTR NO:	TIN NO:		

DRAWN BY:

PROJECT TITLE
 PROPOSED ENGINEERING AND ARCHITECTURE BUILDING

LOCATION: CQT. AVE. BRGY. SALAWAG, DASMARIÑAS CITY, CAVITE, PHILIPPINES.

SHEET CONTENT
 TOILET DETAILS

SHEET NO.
 A
 12

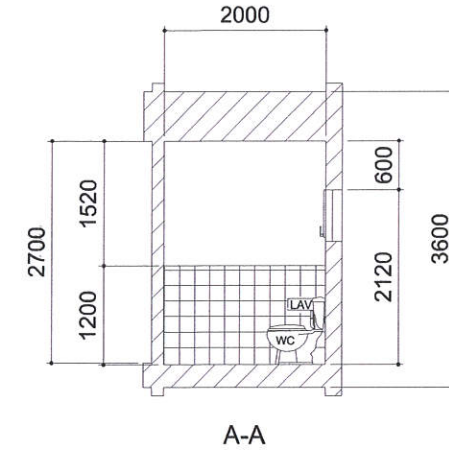
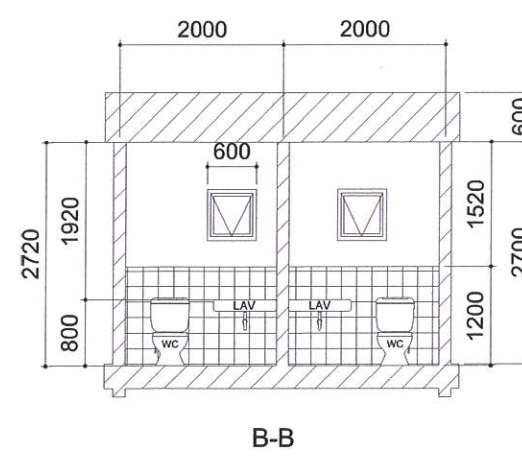
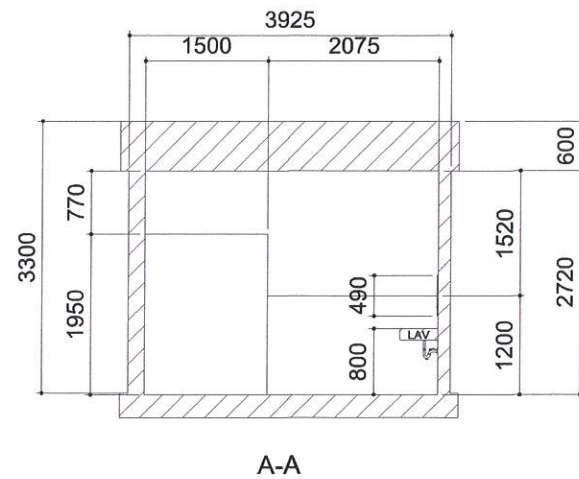
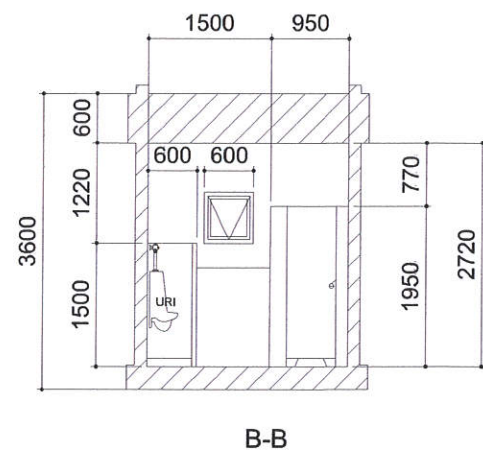
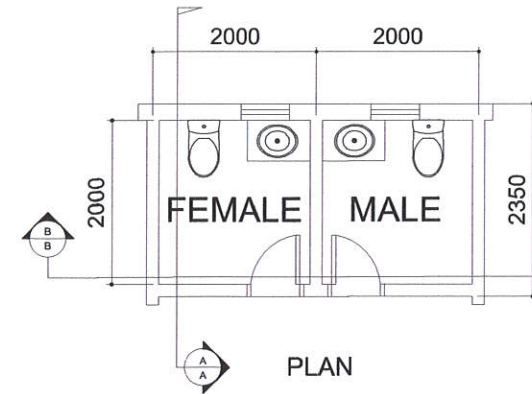
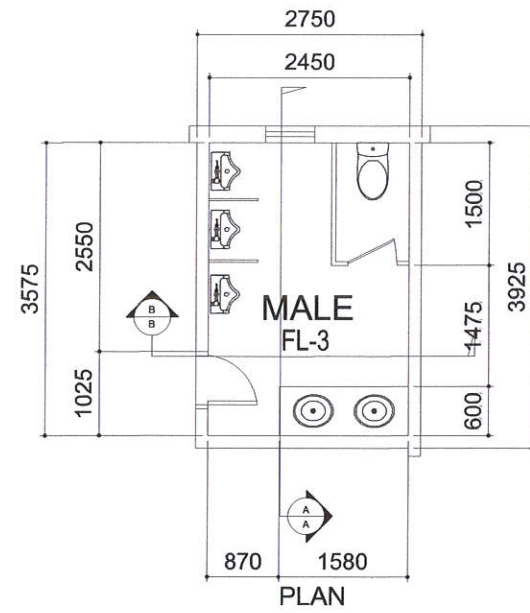

(SECOND FLOOR)
MALE TOILET
SCALE: 1:100 METERS

(SIXTH FLOOR)
FEMALE & MALE TOILET
SCALE: 1:100 METERS

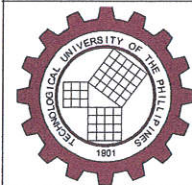

TUP
CAVITE

OWNER
TECHNOLOGICAL UNIVERSITY OF THE PHILIPPINES
CAVITE CAMPUS

ARCHITECT/ENGINEER

REG NO:
DATE EXPIRED:
PTR NO:

DATE ISSUED:
PLACE ISSUED:
TIN NO:

DRAWN BY:

REV NO:

DATE:

PROJECT TITLE

PROPOSED ENGINEERING AND ARCHITECTURE BUILDING

LOCATION: CQT, AVE. BRGY. SALAWAG, DASMARIÑAS CITY, CAVITE, PHILIPPINES.

SHEET CONTENT

TOILET DETAILS

SHEET NO.

A
13

1.0 GENERAL :

- 1.1 ALL DIMENSIONS ARE SHOWN IN MILLIMETERS, ELEVATIONS ARE IN METERS, UNLESS NOTED OTHERWISE.
- 1.2 THE CONTRACTOR SHALL VERIFY ALL DIMENSIONS AND CONDITIONS AT THE SITE, AND SHALL NOTIFY THE ENGINEER OF DISCREPANCIES BETWEEN ACTUAL CONDITIONS AND INFORMATION SHOWN ON THE DRAWINGS BEFORE PROCEEDING WITH THE WORK. THIS SHALL INCLUDE THE LOCATIONS AND DIMENSIONS OF GROOVES, REGLETS, SLEEVES, CURBS, OPENINGS, EMBEDDED OR ATTACHED ITEMS, ETC. REFER TO ARCHITECTURAL, MECHANICAL, ELECTRICAL AND PLUMBING DRAWINGS.
- 1.3 ALL DIMENSIONS SHALL TAKE PRECEDENCE OVER SCALE SHOWN ON PLANS, SECTIONS OR DETAILS. NOTES AND DETAILS ON DRAWINGS SHALL TAKE PRECEDENCE OVER GENERAL NOTES AND TYPICAL DETAILS.
- 1.4 THE CONTRACTOR SHALL IMMEDIATELY NOTIFY THE OWNER AND/OR THE ENGINEER OF ANY CONDITION WHICH IN HIS OPINION MIGHT ENDANGER THE STABILITY OF THE STRUCTURES OR CAUSE DISTRESS IN THE STRUCTURES.
- 1.5 THE CONTRACTOR SHALL TAKE ALL STEPS NECESSARY TO ENSURE THE PROPER ALIGNMENT OF THE STRUCTURES AFTER THE INSTALLATION OF ALL STRUCTURAL AND FINISH MATERIALS.
- 1.6 CONTRACTOR SHALL BE RESPONSIBLE FOR THE COST OF ADDITIONAL WORK BY THE ENGINEER DUE TO SELECTION OF AN OPTION, SUBSTITUTION OF MATERIAL, OR DUE TO ERRORS OR OMISSION IN CONSTRUCTION BY CONTRACTOR.
- 1.7 SPECIAL NOTE: DIMENSIONS INDICATED ON THE STRUCTURAL DRAWINGS SHALL BE COORDINATED WITH THE ARCHITECTURAL DRAWINGS. ARCHITECTURAL DRAWINGS SHALL BE USED TO DEFINE DETAIL CONFIGURATIONS, ELEVATIONS, OPENINGS, JOINTS, SLOPES, ETC.
- 1.8 TYPICAL DETAILS AND GENERAL NOTES SHALL APPLY TO ALL PARTS OF THE JOB UNLESS OTHERWISE SHOWN ON THE DRAWINGS.

2.0 STANDARDS AND REFERENCES :

THE FOLLOWING SHALL GOVERN THE DESIGN, FABRICATION AND CONSTRUCTION OF THE PROJECT :

- 2.1 AMERICAN CONCRETE INSTITUTE (ACI PUBLICATIONS) :
 ACI 318-05 BLDG. CODE REQUIREMENTS FOR REINFORCED CONCRETE
 ACI 315-99 MANUAL OF STANDARD PRACTICE FOR DETAILS AND DETAILING OF CONCRETE REINFORCEMENT.
 ACI 301-05 STANDARD SPECIFICATION FOR STRUCTURAL CONCRETE
- 2.2 NATIONAL STRUCTURAL CODE OF THE PHILIPPINES (NSCP) VOL. 1, FIFTH EDITION, 2001.

3.0 BASIC DESIGN LOADS

3.1 DEAD LOADS, (D)

REINFORCED CONCRETE	24.0	kN/m ³
STRUCTURAL STEEL	77.0	kN/m ³
SOIL	18.0	kN/m ³
WATER	9.81	kN/m ³
CERAMIC TILE FLOOR FINISH	1.00	kPa
CEMENT FILL FINISH	0.70	kPa
100mm THICK CHB WALL	2.11	kPa
150mm THICK CHB WALL	2.73	kPa
CEILING	0.15	kPa
MECHANICAL & ELECTRICAL FIXTURES	0.25	kPa
MISCELLANEOUS		
MEMBRANE WATERPROOFING	0.26	kPa

3.2 OCCUPANCY LIVE LOADS, (L)

ROOF	1.0	kPa
BEDROOMS	1.9	kPa

3.3 WIND LOAD (W)

WIND LOADS ARE CALCULATED IN ACCORDANCE WITH NSCP 2001 VOLUME 1 FIFTH EDITION WITH A MINIMUM BASIC WINDSPEED OF 200 KPH (ZONE II - EXPOSURE B).

3.4 SEISMIC LOAD (E)

SEISMIC LOAD FOR BUILDINGS ARE CALCULATED IN ACCORDANCE WITH NSCP 2001 VOLUME 1 FIFTH EDITION.

SEISMIC DESIGN PARAMETERS ARE AS FOLLOWS :

SEISMIC SOURCE TYPE	C
SOIL PROFILE TYPE	S _D
SEISMIC COEFFICIENT, C _a	0.44 N _a
C _v	0.64 N _v
NEAR SOURCE FACTOR, N _a	1.0
N _v	= 1.0
SEISMIC ZONE FACTOR (ZONE 4)	Z = 0.40
IMPORTANCE FACTOR	I = 1.0
NUMERICAL COEFF. (NSCP TABLE 208-11)	R = 8.5 (SMRF)

4.0 MATERIALS :

4.1 NORMAL WEIGHT CONCRETE :

- 4.1.1 CONCRETE USED IN THIS WORK, UNLESS OTHERWISE STATED ON PLANS, SHALL BE READY-MIX AND HAVE A MINIMUM COMPRESSIVE STRENGTH @ 28 DAYS OF:
 f_c' = 30.00 MPa ALL STRUCTURAL MEMBERS
 f_c' = 20.69 MPa FOR SLAB ON GRADE (INCLUDING GUTTER) EXCEPT SPECIFIED BELOW
 f_c' = 7.0 MPa FOR LEAN CONCRETE
- 4.1.2 ALL CONCRETE SHALL BE DEPOSITED, VIBRATED AND CURED IN ACCORDANCE WITH ACI STANDARD 318-05.
- 4.1.3 MIN CONCRETE COVER FOR REINFORCING BARS SHALL BE AS FOLLOWS:
 A. FOUNDATION = 75 MM (CAST AGAINST EARTH)
 B. BEAMS AND COLUMNS = 40 MM (TO STIRRUPS AND TIES)
 C. WALLS = 25 MM (CAST AGAINST FORMS)
 D. SUSPENDED SLABS = 20 MM

4.2 REINFORCING BARS :

- 4.2.1 REINFORCING STEEL SHALL BE DEFORMED AND SHALL MEET PNS/ASTM A615. THE MINIMUM YIELD STRENGTH SHALL BE AS FOLLOWS:
 FOR Ø10 AND SMALLER:
 f_y = 276 MPa
 FOR Ø12 AND LARGER:
 f_y = 414 MPa
- 4.2.2 ALL REINFORCING BARS SHALL BE CLEAN OF RUST, GREASE OR OTHER MATERIALS WHICH TEND TO IMPAIR BOND.
- 4.2.3 ALL REINFORCING BARS SHALL BE ACCURATELY AND SECURELY PLACED BEFORE POURING CONCRETE OR APPLYING MORTAR OR GROUT.
- 4.2.4 LAPPED SPLICES SHALL BE STAGGERED WHERE POSSIBLE.
- 4.2.5 UNLESS INDICATED OTHERWISE, SPlicing OF REINFORCEMENT SHALL BE IN ACCORDANCE WITH ACI STANDARD 318-08 AND SHALL NOT EXCEED THAT SPECIFIED IN ITEM 4.2.12.
- 4.2.6 UNLESS INDICATED OTHERWISE, ALL BEAMS TERMINATING AT THE COLUMN SHALL HAVE TOP AND BOTTOM BARS EXTENDING TO THE FAR FACE OF THE COLUMN, TERMINATING IN A STANDARD 90° HOOK, LENGTH OF ANCHORAGE SHALL NOT BE LESS THAN 8d_b OR 150MM.
- 4.2.7 SHOP DRAWINGS FOR BENDING AND CUTTING OF REINFORCEMENT SHALL BE SUBMITTED FOR APPROVAL TO THE ENGINEER PRIOR TO FABRICATION.
- 4.2.8 CLEAR SPACING BETWEEN REINFORCING BARS SHALL NOT BE LESS THAN:
 1.5d_b NOR 40MM FOR COLUMNS
 1.0d_b NOR 25MM FOR OTHER MEMBERS
- 4.2.9 UNLESS SHOWN OTHERWISE ON PLANS, SPLICES SHALL BE AS FOLLOWS :
 A. BEAMS AND FOOTING TIE BEAMS :
 AT LEAST TWO EXTRA STIRRUPS-TIES SHALL BE PROVIDED AT ALL SPLICES. THE SPLICE LENGTH SHALL NOT BE LESS THAN THE LENGTH IN TABLE OF LAP SPLICE BELOW.
 B. COLUMNS : SPLICES WHEN PERMITTED SHALL BE MADE WITHIN THE CENTER HALF OF COLUMN HEIGHT, AND THE LAP SPLICE SHALL NOT BE LESS THAN LD SPECIFIED IN TABLE OF LAP SPLICE. THE USE OF APPROVED MECHANICAL DEVICES MAY BE PERMITTED PROVIDED THAT NOT MORE THAN ALTERNATE BARS ARE SPLICED AT ANY LEVEL AND THE MINIMUM VERTICAL DISTANCE BETWEEN TWO ADJACENT BAR SPLICES SHALL BE 600MM.
 C. CHB WALLS : VERTICAL BARS SHALL BE SPLICED AT THE TOP OF WALL FOOTING OR TIE BEAM AND AT THE BOTTOM OF RC LINTEL BEAM OR BEAMS.

4.2.10 WELDING OF REINFORCEMENT IS NOT PERMITTED UNLESS OTHERWISE SHOWN ON THE DRAWINGS. WELDING OF REINFORCEMENT SHALL CONFORM TO AWS D1.4. ASTM A706 SHALL BE USED FOR WELDED REINFORCING STEEL. REINFORCEMENT NOT CONFORMING TO ASTM A706 MAY BE USED IF MATERIAL PROPERTIES OF THE REPLACEMENT STEEL CONFORM TO AWS D1.4.

4.2.11 DEVELOPMENT AND SPLICE LENGTHS OF REINFORCEMENT BARS SHALL BE AS FOLLOWS: BE SUBMITTED FOR APPROVAL TO THE ENGINEER PRIOR TO FABRICATION.

- 4.3 CONCRETE HOLLOW BLOCK UNITS (CHB) :
 4.3.1 CHB USED IN THESE WORKS SHALL HAVE A MINIMUM ULTIMATE COMPRESSIVE STRENGTH @ 28 DAYS OF f_m' = 2.5 MPa (350 PSI) 100/150 MM THICK NON-LOAD BEARING CHB.
 4.3.2 ALL CELLS SHALL BE SOLIDLY FILLED WITH CONCRETE MORTAR, CONCRETE MORTAR SHALL HAVE A MINIMUM COMPRESSIVE STRENGTH OF 17.20 MPa (2500 PSI) @ 28 DAYS.

5.0 FORMWORKS :

- 5.1 FORMS SHALL BE PROVIDED FOR ALL CONCRETE NOT INDICATED OF SPECIFIED OTHERWISE. THE CONTRACTOR SHALL BE RESPONSIBLE FOR THE ADEQUACY OF FORMS AND FORM SUPPORTS. ALL FORMWORKS SHALL BE PROVIDED WITH ADEQUATE CLEAN-OUT OPENINGS TO PERMIT INSPECTION AND EASY CLEANING AFTER ALL REINFORCEMENT HAS BEEN PLACED. ALL FORMS SHALL BE CONSTRUCTED SO THAT THEY CAN BE REMOVED WITHOUT DAMAGING THE CONCRETE.
 - 5.2 FORMS SHALL BE REMOVED IN A MANNER WHICH WILL PREVENT DAMAGE TO THE CONCRETE. FORMS SHALL NOT BE REMOVED, WITHOUT APPROVAL OF THE ENGINEER, OR BEFORE EXPIRATION OF THE MINIMUM PANELS SPECIFIED HEREIN:
- | | DAYS AFTER PLACING |
|---|--------------------|
| FOUNDATION | 1 |
| SUSPENDED SLAB EXCEPT WHEN ADDITIONAL LOADS ARE IMPOSED | 8 |
| FORMS FOR COLUMNS (LIFTS OVER 4.5M) | 7 |
| SUPPORTING FORMS FOR SLABS, BEAMS, GIRDERS | 14 |
- SUFFICIENT SHORING TO SUPPORT THE DEAD LOAD PLUS CONSTRUCTIONLOADS ON BEAMS, GIRDERS AND SLABS SHALL BE PROVIDED FOR A PERIOD OF 14 DAYS IN ADDITION TO THE 14 DAYS SPECIFIED HEREIN, PROVIDED ALL CONCRETE TEST RESULTS HAS SHOWN SUFFICIENT STRENGTH FOR 28 DAYS.

6.0 CAMBER REQUIREMENTS :

- 6.1 UNLESS OTHERWISE NOTED ON THE PLANS OR SPECIFICATIONS CAMBER ALL RC BEAMS AT LEAST 10mm. FOR EVERY 4000mm. OF CLEAR SPAN EXCEPT CANTILEVERS WHICH SHALL BE 50mm. FOR EVERY 3000mm. OF CLEAR SPAN.
- 6.2 UNLESS OTHERWISE NOTED IN PLANS OR SPECIFICATIONS, CAMBER ALL SLABS 8mm PER 3000mm. OF SHORTER SPAN AND 14mm. FOR EVERY 2000mm. OF SLABS CANTILEVER SPAN

7.0 FOUNDATIONS :

- 7.1 ALL FOOTINGS/FOUNDATIONS WERE DESIGNED USING ASSUMED GROSS ALLOWABLE SOIL BEARING CAPACITY OF 143 KPa AT DEPTHS INDICATED IN THE DRAWING. CONFIRMATION OF ACTUAL SOIL BEARING CAPACITY SHALL BE DONE PRIOR TO CONSTRUCTION OF FOUNDATION. INCREASE IN FOUNDATION SIZE SHALL BE DONE WHEN ACTUAL SOIL BEARING CAPACITY CONFIRMED DURING EXCAVATION WARRANT REVISION OF FOUNDATION SIZES.
- 7.2 FOR FOOTINGS AND FOUNDATIONS RESTING ON FILL, THE FILL MATERIALS UNDERNEATH SHALL BE SELECTED STRUCTURAL FILL CLASSIFIED AS GW, GP, SW, SP OF THE TECHNICAL SPECIFICATION SECTION 02221. PLACE AND COMPACT FILL IN ACCORDANCE WITH THE ABOVE TECHNICAL SPECIFICATIONS.
- 7.3 WHERE LOOSE/SOFT MATERIAL IS ENCOUNTERED AT DEPTH OF FOOTING/FOUNDATION INDICATED, EXCAVATE TO FIRM LAYER AND REPLACE LOOSE/SOFT MATERIALS UNDERNEATH THE FOOTING WITHIN THE FOOTING AREA PLUS 1/2 DEPTH OF SOIL MATERIAL ON ALL SIDES WITH SELECTED BACKFILL. COMPACT SELECTED BACKFILL TO 95% MAXIMUM DRY DENSITY (ASTM D1557).
- 7.4 FILL/BACKFILL SHALL BE PLACED IN 200MM LAYERS AND EACH LAYER SHALL BE COMPACTED TO 95% MAXIMUM DRY DENSITY BEFORE SUBSEQUENT LAYERS ARE TO BE LAID.
- 7.5 ALL EQUIPMENT FOUNDATIONS SHALL REST ON A 50MM LEAN CONCRETE ON A WELL COMPACTED SUBGRADE. SLAB ON GRADE AND OTHER STRUCTURAL ELEMENTS SHALL REST ON A 150MM COMPACTED GRAVEL BEDDING UNLESS OTHERWISE NOTED.

TABLE OF LAP SPLICE

PARAMETERS											
MATERIAL	psi	MPa	ACI 318-05								
f _c	3000	20.7	DEV'T & SPLICE LENGTH								
f _y	60000	414	12mm & HIGHER								
f _{yh}	40000	276	10mm & LOWER								
tie #	10	stirrup #	10	40000							
BAR (mm)	ANCHORAGE LENGTH (mm)	L _d (mm)	STANDARD HOOK (mm)			BEAM COMP. SPLICE (mm)		TENSION LAP SPLICE (mm)		UNIT WT. (kg/m)	
			90°	180°	135°-90°	LAP CLASS	TOP BAR	BOTTOM BAR	TIED	SPIRAL	
10	600	150	160	110	120-120	300	A 380	300	300	300	0.616
							B 480	390			
12	710	260	200	120	130-130	350	A 680	520	520	520	0.888
							B 880	680			
16	950	350	260	130	160-160	460	A 910	700	700	700	1.579
							B 1180	910			
20	1180	440	320	160	200-320	580	A 1140	870	870	870	2.466
							B 1480	1130			
25	1900	550	400	200	250-400	720	A 1780	1370	1370	1370	3.854
							B 2310	1780			
32	2190	620	480	260		810	A 1990	1530	1530	1530	4.833
							B 2590	1990			
38	2590	700	550	290		930	A 2270	1750	1750	1750	6.313
							B 2950	2280			
36	2990	790	650	360		1040	A 2560	1970	1970	1970	7.991
							B 3330	2560			

NOTES:
 1. DEVELOPMENT LENGTH OF INDIVIDUAL BARS WITHIN A BUNDLE, IN TENSION OR COMPRESSION, SHALL BE THAT FOR INDIVIDUAL BARS, INCREASED 20% FOR THREE-BUNDLED AND 33% FOR FOUR-BUNDLED BARS.
 2. FOR COLUMNS AT ANY LEVEL, NO MORE THAN ALTERNATE BARS SHOULD BE SPLICED, NOT MORE THAN 33% OF THE BARS SHALL BE SPLICED WITHIN THE REQUIRED LAP LENGTH. MINIMUM DISTANCE BETWEEN TWO ADJACENT SPLICES SHALL BE 600mm.
 3. TOP BARS ARE HORIZONTAL BARS WITH MORE THAN 300mm DEPTH OF CONCRETE CAST BELOW REINFORCEMENT.
 4. LAP SPLICE SHALL BE CLASS B TENSION LAP SPLICE IF MORE THAN ONE HALF OF THE BARS WERE SPLICED AT ANY SECTION, WHILE CLASS A TENSION LAP SPLICE IF HALF OR FEWER THAN HALF OF BARS WERE SPLICED.
 5. TOP BARS SPLICE FOR BEAMS, SHOULD BE "BEAM COMPRESSIVE SPLICE x1.3"

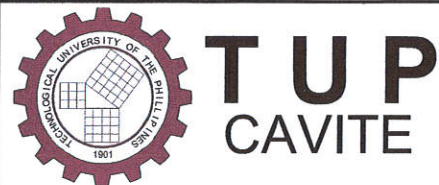

OWNER
 TECHNOLOGICAL UNIVERSITY OF THE PHILIPPINES
 CAVITE CAMPUS

CIVIL ENGINEER

REG NO:	DATE ISSUED:
DATE EXPIRED:	PLACE ISSUED:
PTR NO:	TIN NO:

DRAWN BY:
 INFRASTRUCTURE DEVELOPMENT OFFICE

REV NO: DATE:

PROJECT TITLE
 PROPOSED ENGINEERING AND ARCHITECTURE BUILDING

LOCATION: CQT. AVE. BRGY. SALAWAG, DASMARIÑAS CITY, CAVITE, PHILIPPINES.

SHEET CONTENT
 AS SHOWN

SHEET NO.

S
 01

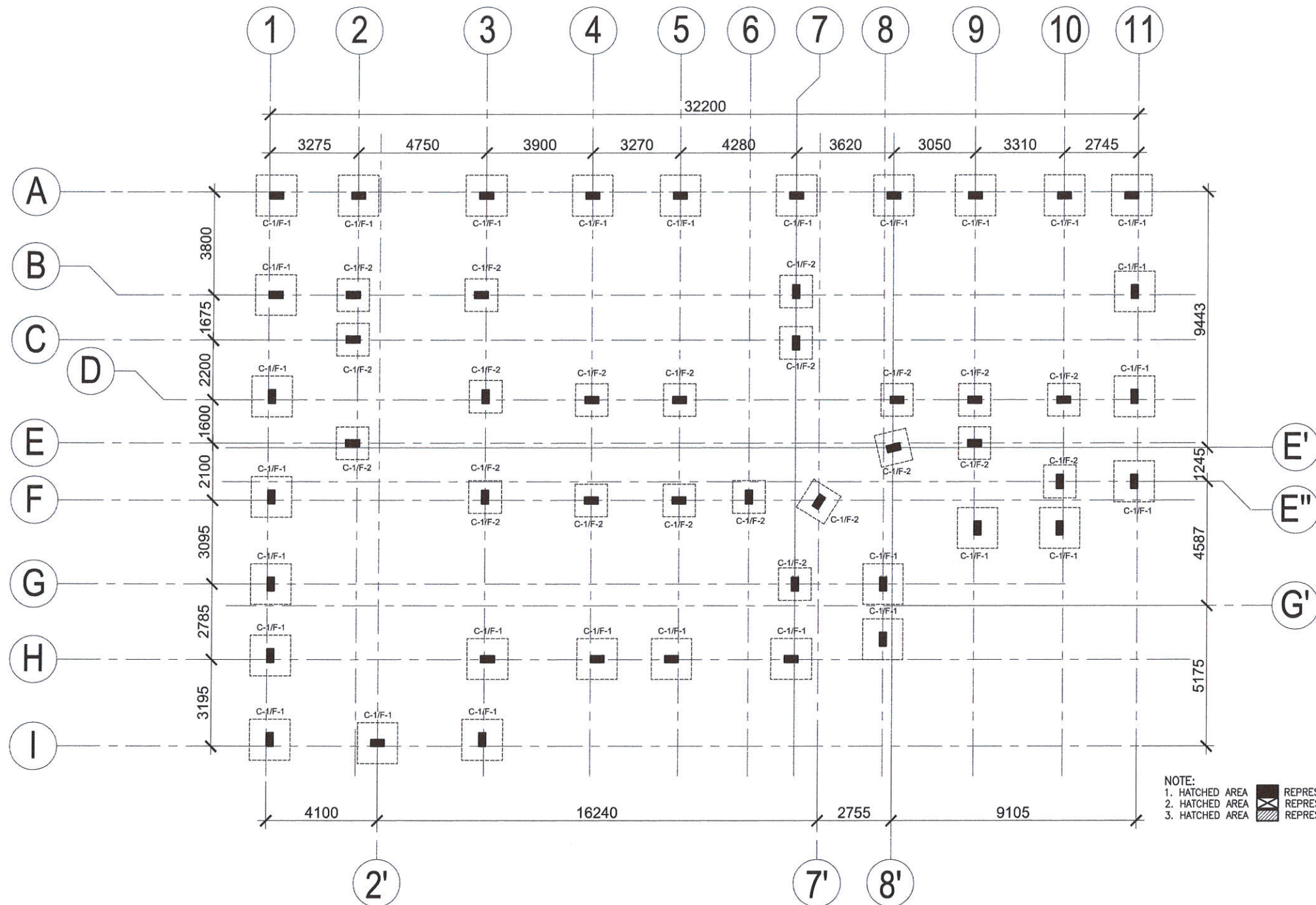

NOTE:
 1. HATCHED AREA REPRESENTS CONTINUOUS COLUMN
 2. HATCHED AREA REPRESENTS PLANTED COLUMN
 3. HATCHED AREA REPRESENTS TERMINATED COLUMN

1
 S-2 ENGINEERING AND ARCHITECTURE BUILDING
 FOUNDATION PLAN
 SCALE 1:100 M

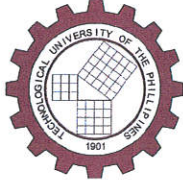
 TUP CAVITE	OWNER	CIVIL ENGINEER REG NO: _____ DATE ISSUED: _____ DATE EXPIRED: _____ PLACE ISSUED: _____ PTR NO: _____ TIN NO: _____	DRAWN BY:	PROJECT TITLE	SHEET CONTENT	SHEET NO.
	TECHNOLOGICAL UNIVERSITY OF THE PHILIPPINES CAVITE CAMPUS		INFRASTRUCTURE DEVELOPMENT OFFICE	PROPOSED ENGINEERING AND ARCHITECTURE BUILDING	AS SHOWN	S 02
	LOCATION: CQT, AVE, BRGY, SALAWAG, DASMARIÑAS CITY, CAVITE, PHILIPPINES		REV NO.: _____ DATE: _____			

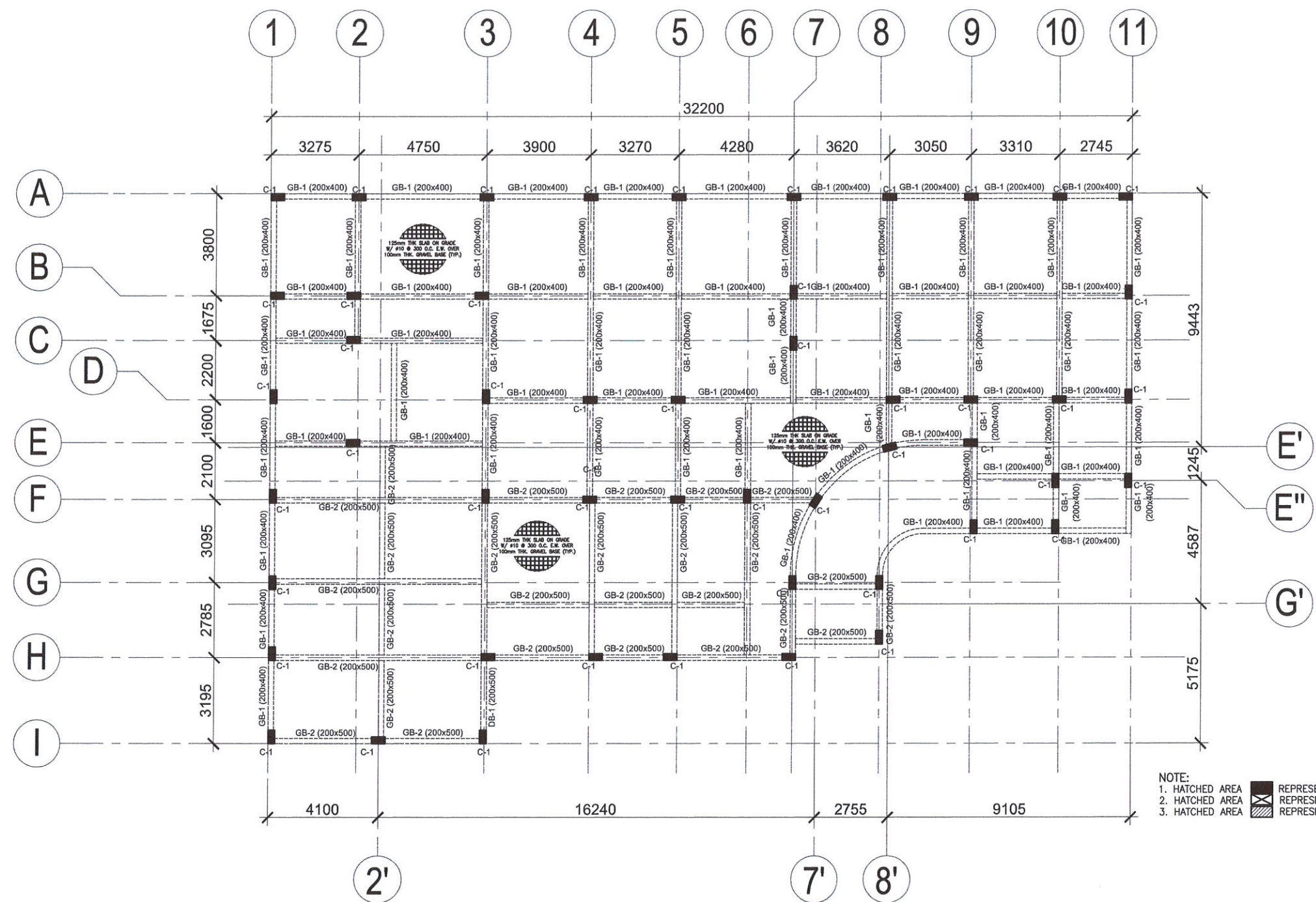

1 ENGINEERING AND ARCHITECTURE BUILDING
 S-3 GROUND FLOOR FRAMING PLAN
 SCALE 1:100 M



TUP
 CAVITE

OWNER
 TECHNOLOGICAL UNIVERSITY OF THE PHILIPPINES
 CAVITE CAMPUS

CIVIL ENGINEER
 REG NO: _____ DATE ISSUED: _____
 DATE EXPIRED: _____ PLACE ISSUED: _____
 PTR NO: _____ TIN NO: _____

DRAWN BY:
 INFRASTRUCTURE
 DEVELOPMENT OFFICE

REV NO.: _____ DATE: _____

PROJECT TITLE
 PROPOSED ENGINEERING AND
 ARCHITECTURE BUILDING
 LOCATION: CQT. AVE. BRGY. SALAWAG, DASMARIÑAS CITY, CAVITE, PHILIPPINES

SHEET CONTENT
 AS SHOWN

SHEET NO.
 S
 03

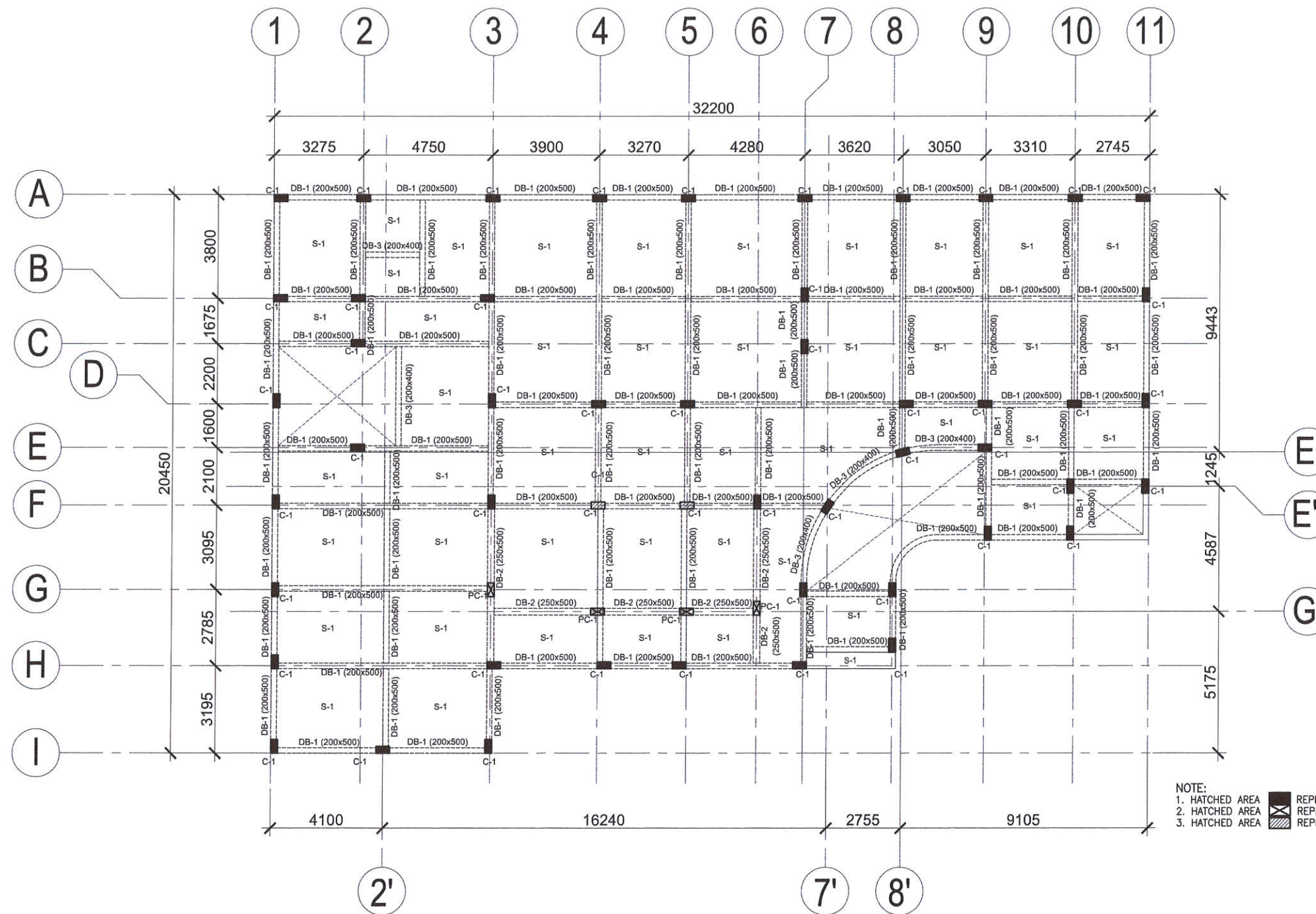

1
S-4

ENGINEERING AND ARCHITECTURE BUILDING
SECOND FLOOR FRAMING PLAN

SCALE 1:100 M

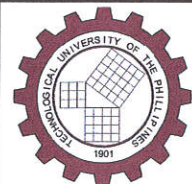

TUP
CAVITE

OWNER
TECHNOLOGICAL UNIVERSITY OF THE PHILIPPINES
CAVITE CAMPUS

CIVIL ENGINEER

REG NO:
DATE EXPIRED:
PTR NO:

DATE ISSUED:
PLACE ISSUED:
TIN NO:

DRAWN BY:
INFRASTRUCTURE
DEVELOPMENT OFFICE

REV NO.: DATE:

PROJECT TITLE

PROPOSED ENGINEERING AND
ARCHITECTURE BUILDING

LOCATION: CQT. AVE. BRGY. SALAWAG, DASMARIÑAS CITY, CAVITE, PHILIPPINES.

SHEET CONTENT
AS SHOWN

SHEET NO.

S
04

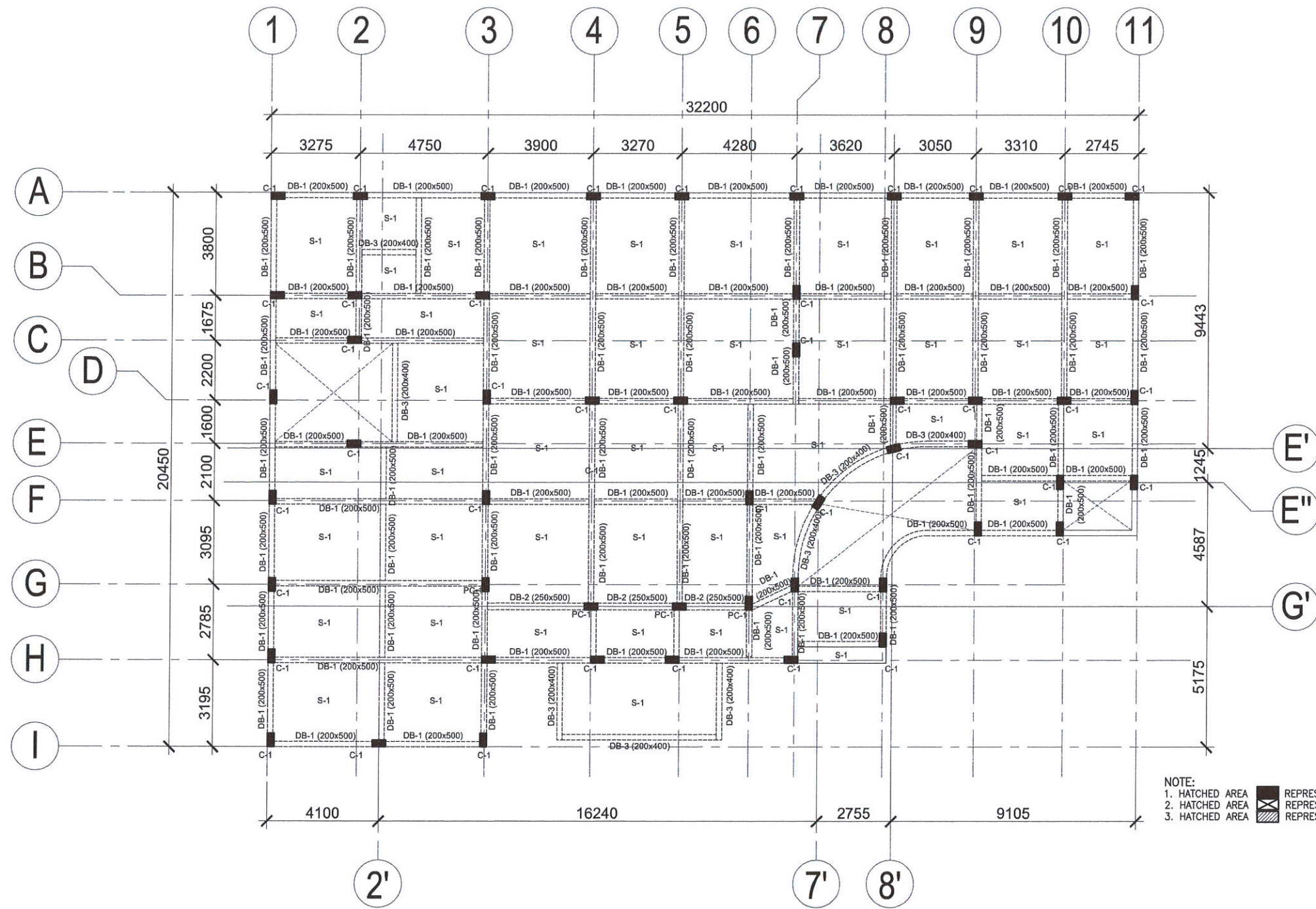

1
S-5

ENGINEERING AND ARCHITECTURE BUILDING
3RD TO 5TH FLOOR FRAMING PLAN

SCALE 1:100 M

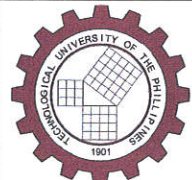

TUP
CAVITE

OWNER
TECHNOLOGICAL UNIVERSITY OF THE PHILIPPINES
CAVITE CAMPUS

CIVIL ENGINEER

REG NO: _____ DATE ISSUED: _____
DATE EXPIRED: _____ PLACE ISSUED: _____
PTR NO: _____ TIN NO: _____

DRAWN BY:
INFRASTRUCTURE
DEVELOPMENT OFFICE

REV NO: _____ DATE: _____

PROJECT TITLE
PROPOSED ENGINEERING AND
ARCHITECTURE BUILDING

LOCATION: CQT. AVE. BRGY. SALAWAG, DASMARIÑAS CITY, CAVITE, PHILIPPINES

SHEET CONTENT
AS SHOWN

SHEET NO.
S
05

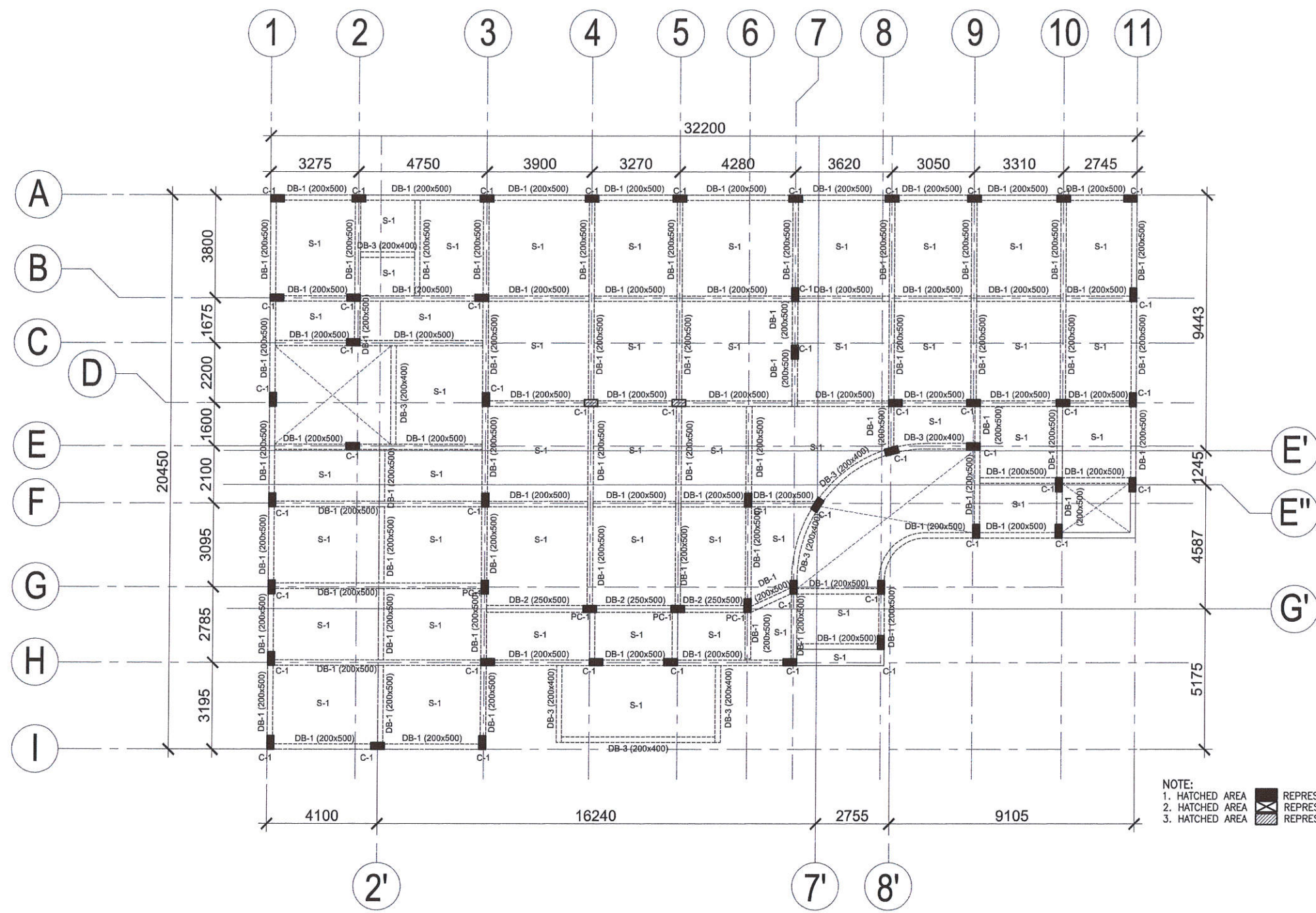

1
S-6

ENGINEERING AND ARCHITECTURE BUILDING
6TH FLOOR FRAMING PLAN

SCALE 1:100 M

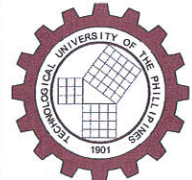

TUP
CAVITE

OWNER
TECHNOLOGICAL UNIVERSITY OF THE PHILIPPINES
CAVITE CAMPUS

CIVIL ENGINEER

REG NO: _____ DATE ISSUED: _____
DATE EXPIRED: _____ PLACE ISSUED: _____
PTR NO: _____ TIN NO: _____

DRAWN BY:
INFRASTRUCTURE DEVELOPMENT OFFICE

REV NO: _____ DATE: _____

PROJECT TITLE
PROPOSED ENGINEERING AND ARCHITECTURE BUILDING

LOCATION: CQT. AVE. BRGY. SALAWAG, DASMARIÑAS CITY, CAVITE, PHILIPPINES

SHEET CONTENT
AS SHOWN

SHEET NO.
S
06

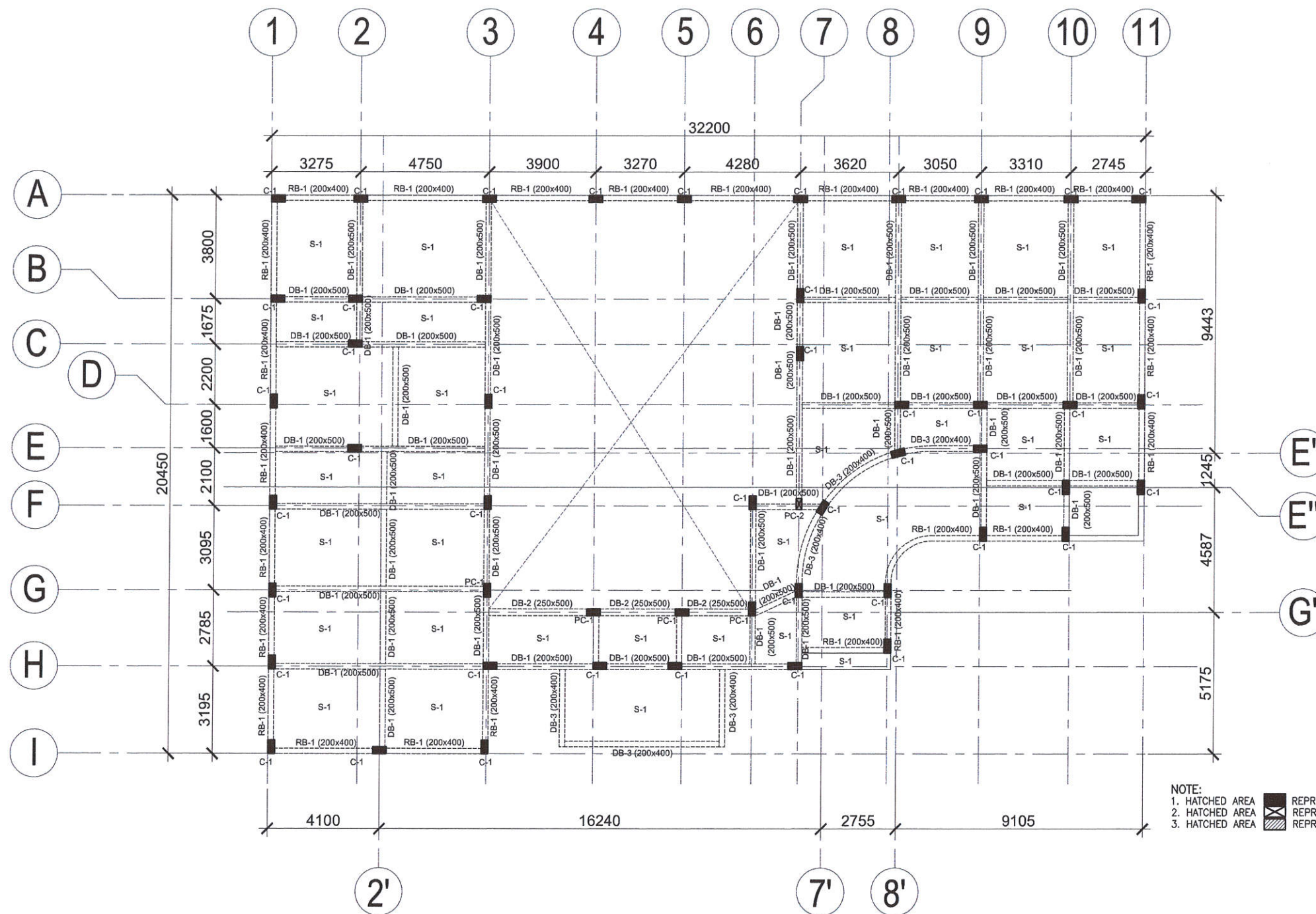

1
S-7

ENGINEERING AND ARCHITECTURE BUILDING
ROOF FRAMING PLAN
 SCALE 1:100 M

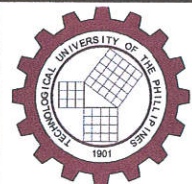

TUP
CAVITE

OWNER
 TECHNOLOGICAL UNIVERSITY OF THE PHILIPPINES
 CAVITE CAMPUS

CIVIL ENGINEER

REG NO:	DATE ISSUED:
DATE EXPIRED:	PLACE ISSUED:
PTR NO:	TIN NO:

DRAWN BY:
 INFRASTRUCTURE DEVELOPMENT OFFICE

REV NO.:	DATE:
----------	-------

PROJECT TITLE
 PROPOSED ENGINEERING AND ARCHITECTURE BUILDING

LOCATION: CQT. AVE. BRGY. SALAWAG, DASMARIÑAS CITY, CAVITE, PHILIPPINES

SHEET CONTENT
 AS SHOWN

SHEET NO.
S
07

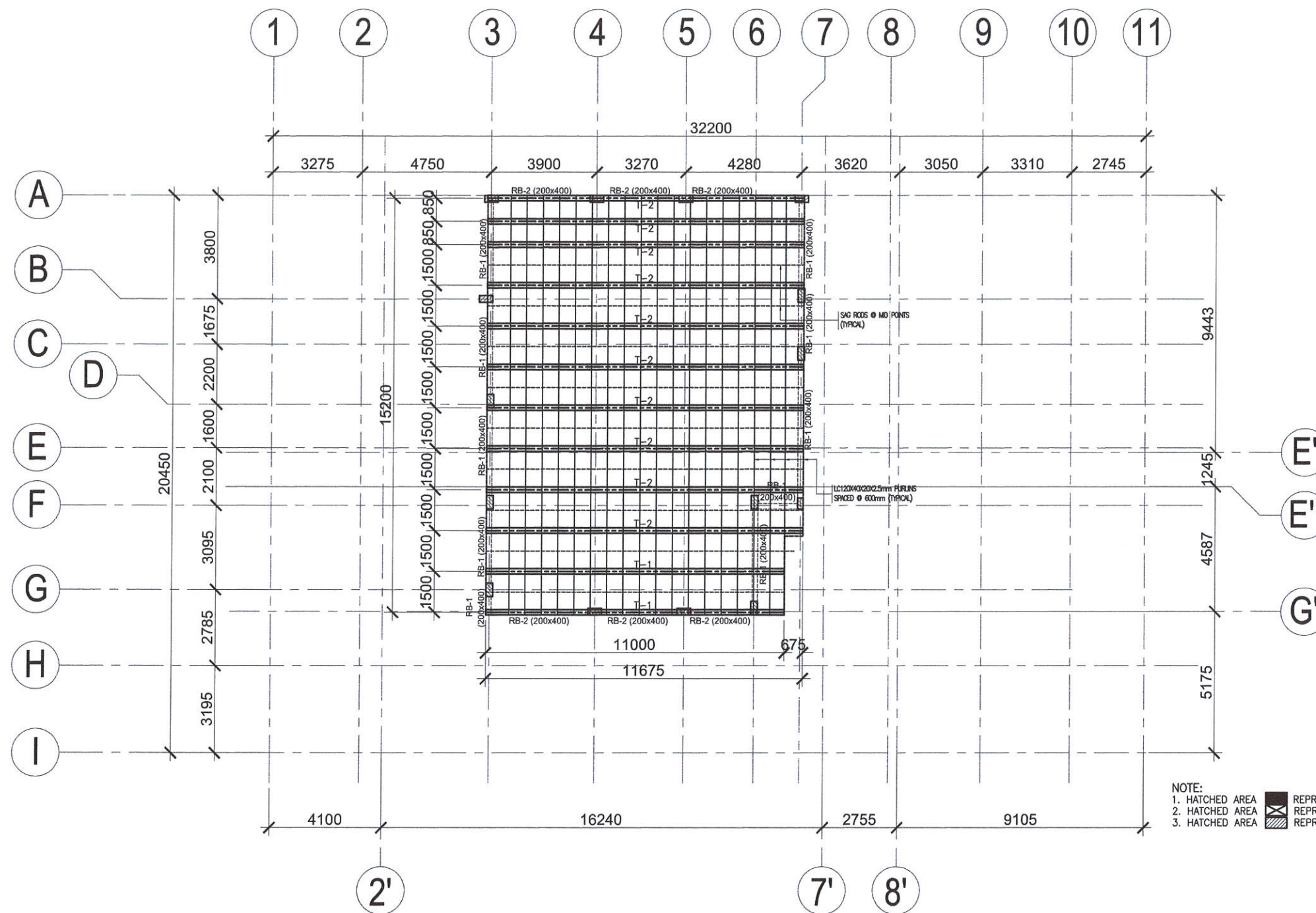

ENGINEERING AND ARCHITECTURE BUILDING
ROOF FRAMING PLAN (MULTIMEDIA CENTER)
 SCALE 1:100

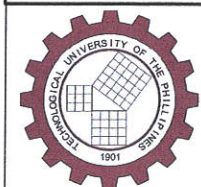

TUP
CAVITE

OWNER
 TECHNOLOGICAL UNIVERSITY OF THE PHILIPPINES
 CAVITE CAMPUS

CIVIL ENGINEER

REG NO:	DATE ISSUED:
DATE EXPIRED:	PLACE ISSUED:
PTR NO:	TIN NO:

DRAWN BY:
 INFRASTRUCTURE
 DEVELOPMENT OFFICE

REV NO.:	DATE:
----------	-------

PROJECT TITLE
 PROPOSED ENGINEERING AND
 ARCHITECTURE BUILDING

LOCATION: CQT. AVE. BRGY. SALAWAG, DASMARIÑAS CITY, CAVITE, PHILIPPINES

SHEET CONTENT
 AS SHOWN

SHEET NO.
S
08

SCHEDULE OF COLUMNS			
COL. MARK	C-1	PC-1	PC-2
FLOOR LEVEL			
VARIOUS LEVELS (SEE FRAMING PLANS)			
SIZE	250x500	250x500	200x400
VERT. REINF.	8-#20MM	6-#20MM	6-#20MM
TIES (a)	2-#16 @ 150MM	2-#16 @ 150MM	2-#16 @ 150MM
CONFIN. REINF. (b)	3-#16 @ 100MM	3-#16 @ 100MM	3-#16 @ 100MM
JOINT REINF. (c)	2-#16 @ 100MM	2-#16 @ 100MM	2-#16 @ 100MM

1 ENGINEERING AND ARCHITECTURE BUILDING
SCHEDULE OF COLUMNS
 SCALE NTS

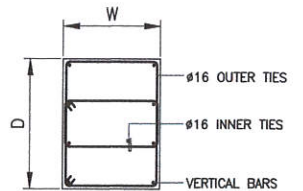

2 ENGINEERING AND ARCHITECTURE BUILDING
COMBINATION OF TIES
 SCALE NTS

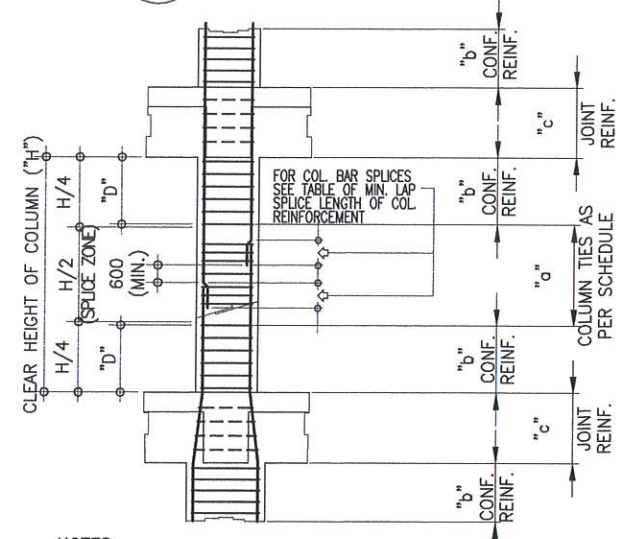

- NOTES:
- YIELD STRESS OF HOOPS = 60/40 KSI
 - D = USE MAXIMUM COLUMN/SHEARWALL DIMENSION, 1/6 CLEAR HEIGHT OR 18" (450mm) WHICHEVER IS GREATER.
 - NUMBER OF HOOP TIES SAME AS PER COLUMN/SHEARWALL TIES SCHEDULE.
 - ALL CONCRETE REINFORCEMENT DETAIL SHOULD BE DONE IN ACCORDANCE WITH ACI DETAILING MANUAL 1980 PUB SP-66
 - SPACING OF TIES WITHIN THE SPLICE SHOULD BE @_@100mm

3 ENGINEERING AND ARCHITECTURE BUILDING
TYPICAL COLUMN ELEVATION
 SCALE NTS

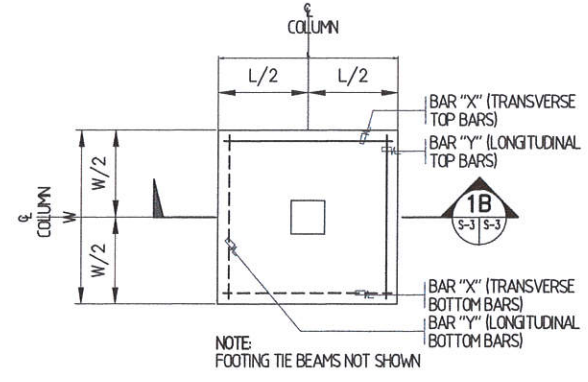

3 ENGINEERING AND ARCHITECTURE BUILDING
TYPICAL FTG. DETAIL
 SCALE NTS

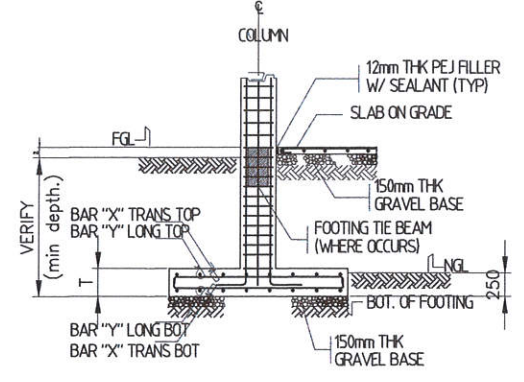

4 ENGINEERING AND ARCHITECTURE BUILDING
SECTION
 SCALE NTS

SCHEDULE OF FOOTINGS						
FOOTING DESIG.	DIMENSIONS (mm)				REINFORCEMENT (mm)	REMARKS
	D (DEPTH)	W (WIDTH)	L (LENGTH)	T (THICKNESS)		
F-1	1500	1500	1500	400	TB BB #16@200 B.W.	ISOLATED FOOTING
F-2	1500	1200	1200	400	TB BB #16@200 B.W.	ISOLATED FOOTING

5 ENGINEERING AND ARCHITECTURE BUILDING
SCHEDULE OF FOOTINGS
 SCALE NTS

SCHEDULE OF SLAB REINFORCEMENT									
SLAB MARK	THICKNESS (mm)	BAR DIA.	SHORT SPAN			LONG SPAN			REMARKS
			TOP BAR DISCONT.	BOTTOM BAR	TOP BAR CONT.	TOP BAR DISCONT.	BOTTOM BAR	TOP BAR CONT.	
S-1	100	#12	200	200	200	200	200	200	SEE FRAMING PLANS

6 ENGINEERING AND ARCHITECTURE BUILDING
SCHEDULE OF SLAB
 SCALE NTS

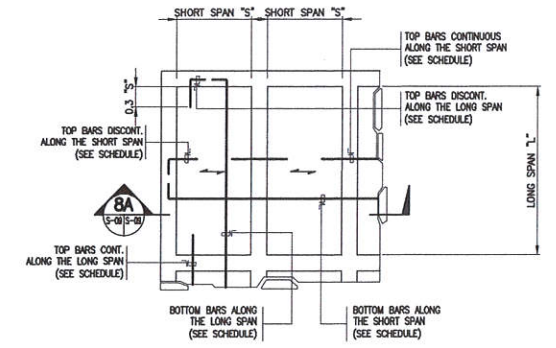

7 ENGINEERING AND ARCHITECTURE BUILDING
TYP. ONE WAY RC SLAB DETAIL
 SCALE NTS

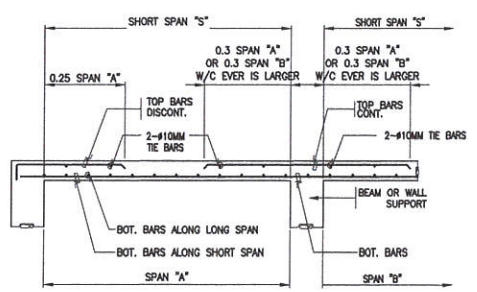

8A SECTION
 NOT TO SCALE

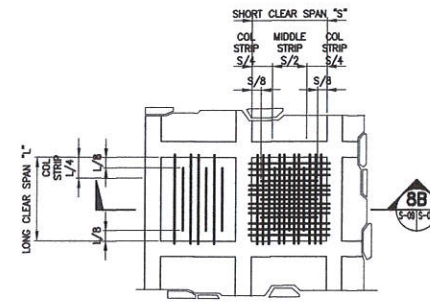

TYP. FRAMING PLAN OF TWO WAY SLAB SHOWING BOTTOM BAR REINFORCEMENT

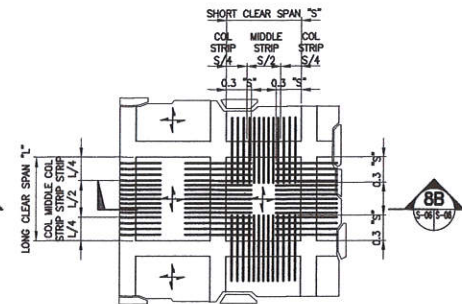

TYP. FRAMING PLAN OF TWO WAY SLAB SHOWING TOP BAR REINFORCEMENT

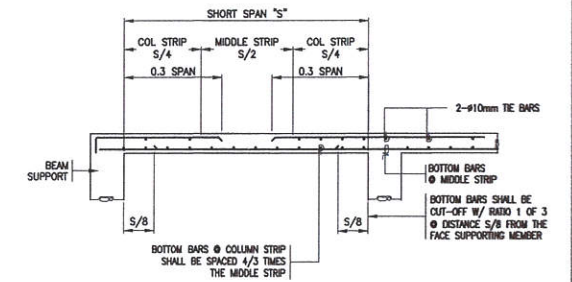

8B SECTION
 NOT TO SCALE

8 ENGINEERING AND ARCHITECTURE BUILDING
TYP. TWO WAY RC SLAB DETAIL
 SCALE NTS

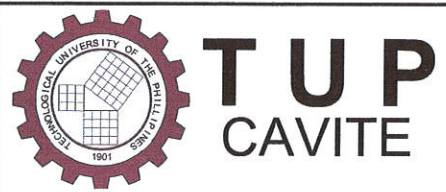

OWNER
 TECHNOLOGICAL UNIVERSITY OF THE PHILIPPINES
 CAVITE CAMPUS

CIVIL ENGINEER

REG NO:	DATE ISSUED:
DATE EXPIRED:	PLACE ISSUED:
PTR NO:	TIN NO:

DRAWN BY:
 INFRASTRUCTURE DEVELOPMENT OFFICE

REV NO.:	DATE:
----------	-------

PROJECT TITLE
 PROPOSED ENGINEERING AND ARCHITECTURE BUILDING

LOCATION: CQT. AVE. BRGY. SALAWAG, DASMARIÑAS CITY, CAVITE, PHILIPPINES

SHEET CONTENT
 AS SHOWN

SHEET NO.
 S
 09

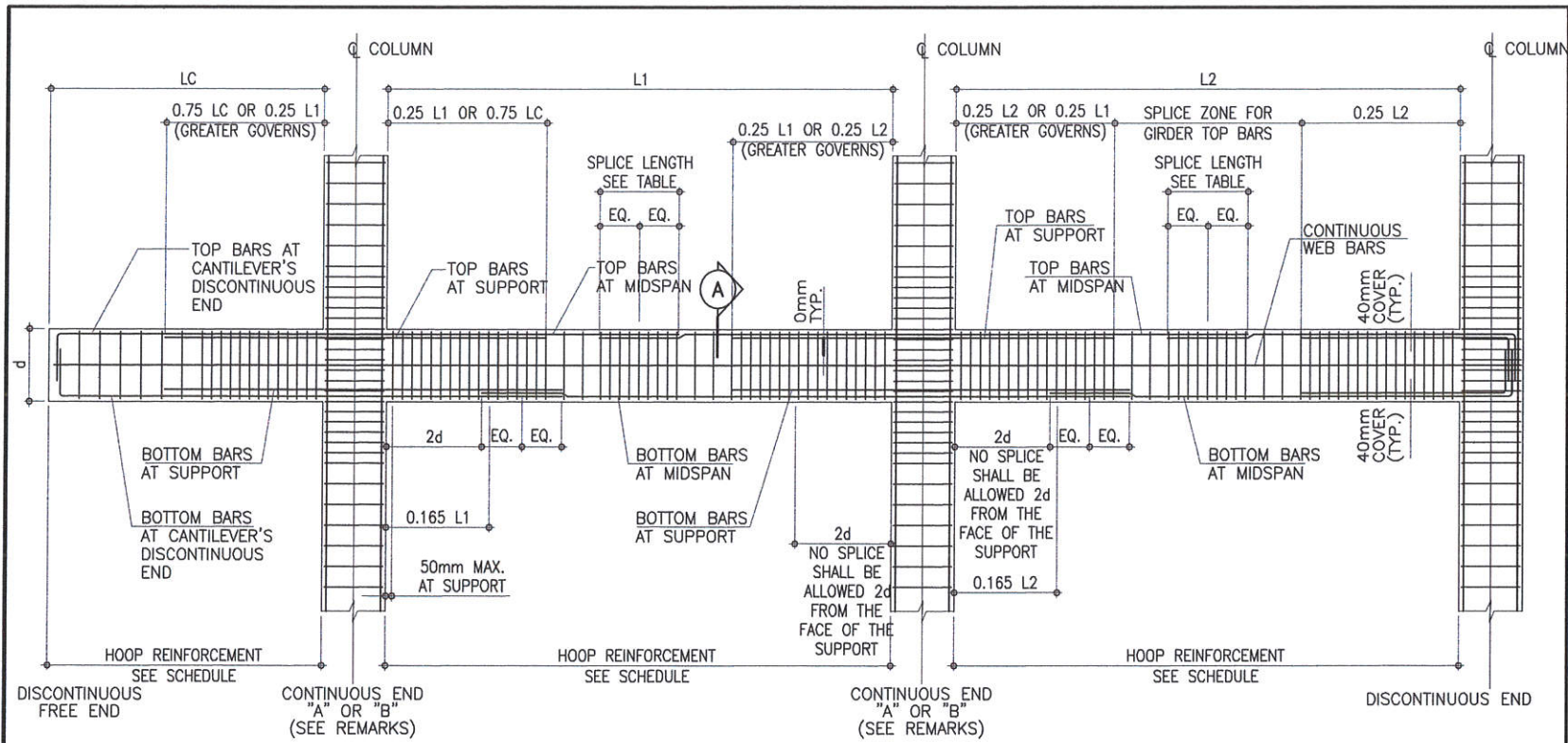

ELEVATION

NOTE: AT INTERIOR SUPPORT (CONTINUOUS END) PROVIDE LARGER SIZE AND LARGER NUMBER OF TOP AND BOTTOM BARS FROM ADJACENT SPAN.
NO SPLICE SHALL OCCUR ON CANTILEVER BEAMS

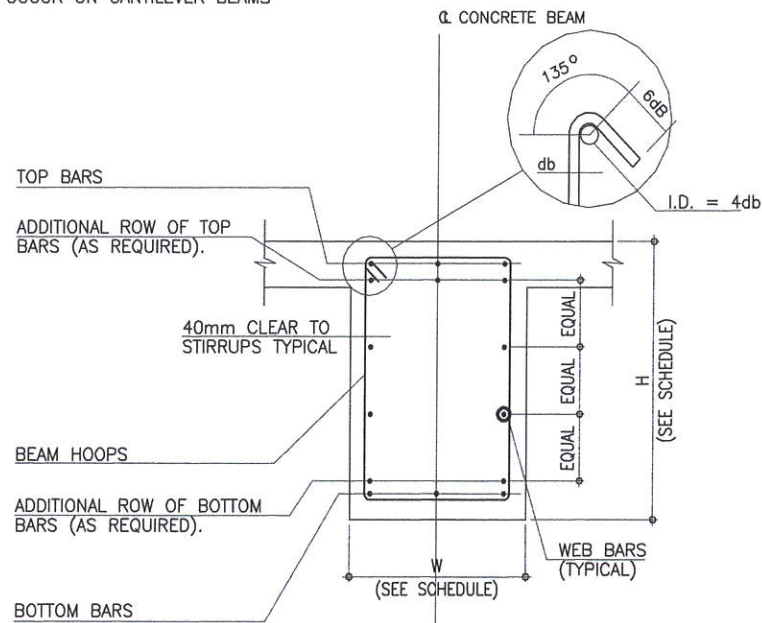

NOTE: SLAB REINFORCEMENT NOT SHOWN FOR CLARITY

SECTION

ENGINEERING AND ARCHITECTURE BUILDING
TYPICAL DUCTILE MOMENT FRAME BEAM DETAIL
SCALE: 1 S-10 NTS

STRUCTURAL NOTES :

- SEE TABLE OF LAP SPLICE & ANCHORAGE LENGTHS SHOWN ON SHEET
- LAP SPLICE SHALL BE LOCATED ONLY WITHIN THE LAP SPLICE ZONE.
- TOP & BOTTOM BARS MAY BE LAP SPICED ONLY ON ONE LOCATION FOR EACH STRING OF BEAMS.
- CLOSED HOOPS WITH A 135° BEND SHALL BE SPACED AT 100 O.C. MAXIMUM AT A DISTANCE 2D FROM THE FACE OF THE SUPPORT. FIRST STIRRUP SHALL 5D FROM THE FACE OF THE SUPPORT.

SCHEDULE OF REINFORCED CONCRETE GIRDERS								
BEAM DESIG.	DIMENSIONS (mm)		REINFORCEMENT (mm)					SIZE & SPACING OF STIRRUPS
	B	D	DISCONT. 'A'	CONT. 'A'	MIDSPAN	CONT. 'B'	DISCONT. 'B'	
SECOND FLOOR LEVEL								
GB-1	200	400	2-#16mm		2-#16mm	2-#16mm		#10□, 1050, 100#100, REST @ 200 TO C.L.
GB-2	200	500	2-#16mm		3-#16mm	3-#16mm		#10□, 1050, 120#100, REST @ 200 TO C.L.
DB-1	200	500	2-#16mm		2-#16mm	2-#16mm		#10□, 1050, 100#100, REST @ 200 TO C.L.
DB-2	200	400	2-#16mm		2-#16mm	2-#16mm		#10□, 1050, 90#100, REST @ 200 TO C.L.
DB-3	200	400	3-#20mm		3-#20mm	3-#20mm		#10□, 1050, 100#100, REST @ 200 TO C.L.
RB-1	200	400	2-#16mm		2-#16mm	2-#16mm		#10□, 1050, 110#100, REST @ 150 TO C.L.
RB-2	200	400	2-#16mm		2-#16mm	2-#16mm		#10□, 1050, 120#100, REST @ 150 TO C.L.

ENGINEERING AND ARCHITECTURE BUILDING
2 SCHEDULE OF REINFORCED CONCRETE GIRDERS NTS
SCALE: S-10

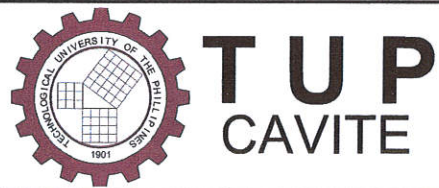

OWNER
TECHNOLOGICAL UNIVERSITY OF THE PHILIPPINES
CAVITE CAMPUS

CIVIL ENGINEER
REG NO.:
DATE EXPIRED:
PTR NO.:
DATE ISSUED:
PLACE ISSUED:
TIN NO.:

DRAWN BY:
INFRASTRUCTURE DEVELOPMENT OFFICE
REV NO.:
DATE:

PROJECT TITLE
PROPOSED ENGINEERING AND ARCHITECTURE BUILDING
LOCATION: CQT. AVE. BRGY. SALAWAG, DASMARIÑAS CITY, CAVITE, PHILIPPINES

SHEET CONTENT
AS SHOWN

SHEET NO.
S
10

GENERAL NOTES

- THE MECHANICAL DRAWINGS SHALL BE READ AS ONE UNIT INCLUDING PLANS, RISER DIAGRAMS AND OTHER DETAILS
- MECHANICAL DRAWINGS SHALL BE READ WITH THE ARCHITECTURAL, STRUCTURAL, ELECTRICAL AND OTHER DRAWINGS FOR COORDINATION, VERIFICATION OF ADEQUATE SPACES AND EARLY DETERMINATION OF ANY CONTRADICTIONS OR INTERFERENCE PER THE PROVISIONS OF THE SPECIFICATION
- THE DRAWINGS ARE ISSUED FOR MECHANICAL WORKS ONLY AND SHALL NOT BE USED FOR ARCHITECTURAL, STRUCTURAL OR OTHER WORKS
- DRAWING IS NOT TO SCALE FOR THE EXECUTION OF WORK. ALL MEASUREMENTS SHALL BE MADE FROM ESTABLISHED LINES, LEVELS AND BENCH MARKS AS DETERMINED ON SITE WITH APPROVAL OF SUPERVISION ENGINEER
- THE DRAWINGS ARE ONLY DIAGRAMMATIC, THE CONTRACTOR SHALL EXECUTE ALL WORK IN ACCORDANCE WITH APPROVED SHOP AND INSTALLATION DRAWINGS PER THE PROVISIONS OF THE SPECIFICATION
- FOR EQUIPMENT CAPACITIES, RATINGS, TYPES AND CHARACTERISTICS REFER TO THE "SCHEDULE OF EQUIPMENT" DRAWINGS. BE READ IN CONJUNCTION WITH SPECIFICATION
- DRAINAGE PIPE CONNECTIONS:
UNLESS OTHERWISE INDICATED THE PIPE CONNECTION TO EACH SANITARY FIXTURE SHALL BE AS FOLLOWS:
SINK: 50MM
FLOOR DRAIN: 75MM
WATER CLOSET: 100MM
SHOWER: 50MM
- ALL PIPE RUNS SHOWN ARE UNDER TILE UNLESS OTHERWISE STATED
- MECHANICAL WORKS REQUIRING ELECTRICAL SERVICES SHALL BE COORDINATED WITH THE ELECTRICAL TRADE
- PIPE MATERIAL WHEN NOT SHOWN ON DRAWINGS SHALL BE AS PER BILL OF QUANTITIES
- ALL DIMENSIONS ARE IN mm UNLESS OTHERWISE STATED
- ALL NOTES STATED ON THE DRAWING SHALL BE RESPECTED BY INSTALLER OR CONTRACTOR

PLUMBING NOTES

- INSTALLATION OF THE EQUIPMENT, PIPE AND FIRRINGS UNDER SLABS SHALL BE EXECUTED IN FULL CORRINATION WITH THE ARCHITECTURAL, LANDSCAPE, STRUCTURAL, ELECTRICAL AND OTHER MECHANICAL DRAWINGS AND SCHEDULES
- ALL MATERIALS AND METHODS OF INSTALLATION SHALL COMPLY FULLY WITH THE REQUIREMENT OF THE LATEST STANDARD AND SHALL BE CONSISTENT WITH AN INSTALLATION OF HIGHER QUALITY
- ALL SUPPORTS AND HANGERS SHALL BE CONCEALED UNLESS OTHERWISE STATED, AND ACCORDANCE WITH MANUFACTURER'S RECOMMENDATION.
- ALL INSTALLATION SHALL BE ACCESSIBLE FOR MAINTENANCE, ENSURE THAT ACCESS DOORS ARE PROVIDED FOR EASY ACCESS TO CONCEALED DRAINS, VALVES AND CLEANOUTS.
- PROVIDE ALL PIPE PENETRATIONS THROUGH WALL PARTITIONS AND SLABS WITH SLEEVE LARGE ENOUGH TO ACCOMMODATE THE PIPE PLUS ANY INSULATION AND THERMAL MOVEMENT. SLEEVE THROUGH INTERIOR WALLS AND PARTITIONS TO BE FLUSH WITH STANDARD SURFACES.
- ALL UNDERGROUND WATER CONNECTION VALVES SHALL HAVE MILD STEEL VALVE BOXES IN ACCESSIBLE LOCATIONS TO FACILITATE EASY REMOVAL, FOR REPAIR OR REPLACEMENT
- CAST IRON SINGLE SEAL COVERS WITH IDENTIFICATION MARKERS SHALL BE PROVIDED FOR ACCESS TO THE VALVES DURING USE AND REPAIRS

-ALL SANITARY FIXTURES WITHOUT INTEGRAL P-TRAPS SUCH AS SHOWER SHALL BE PROVIDED WITH APPROPRIATE P-TRAPS APPROVED BY THE SITE ENGINEER

-THE WATER STORAGE TANKS SHALL INCLUDE FLOAT VALVE, FLOAT BALL, BELL MOUTH INLET AT PUMP SUCTION LINE, RELIEF VENTS, ACCESS LADDER OR CLIMBING RINGS, OVERFLOW PIPE, HIGH AND LOW CUT-OFF LEVEL SWITCHES, SIDE ACCESS WITH AIR TIGHT COVERS AND PROVISIONS FOR PIPE CONNECTIONS

-THE MECHANICAL CONTRACTORS SHALL PROVIDE ELECTRICAL WIRING FOR MECHANICAL EQUIPMENT UP TO THE ISOLATORS PROVIDED BY THE ELECTRICAL CONTRACTOR, THE MECHANICAL CONTRACTOR SHALL BE RESPONSIBLE FOR THE MOTOR CONTROL CENTERS AND CONTROL PANEL OF HIS SUPPLIED EQUIPMENT.

-POTABLE WATER SHALL BE PROVIDED FROM AN UNDER GROUND REINFORCED CONCRETE TANK CONNECTED TO A TRUCK-FILL POINT A CONNECTION LINE TO THE FUTURE MUNICIPALITY WATER MAIN, AND BE FILLED BY A CONNECTION FROM THE WATER NETWORK, SHALL BE PROVIDED.

-COLD WATER PIPING INSIDE THE WET AREA SHALL BE UPVC CLASS (5)

-HOT WATER PIPING INSIDE THE WET AREA SHALL BE CPVC SCH 80 WITH THERMAL INSULATION

PLUMBING NOTES

- WASTE STACKS, VENT PIPING AND DRAIN RUN IN GROUND SHALL BE UPVC CLASS-3 . EXTERNAL SEWER PIPING BELOW GROUND - UNDER SLAB- SHALL BE UPVC CLASS-5 .
- VENT PIPE AND SOIL WASTE STACKS ON ROOF EXPOSED TO SUN JOINING AND FITTING SHALL BE EITHER SOLVENT WELD SOCKETS OR BY RING SEAL PUSH FIT FITTING AS RECOMMENDED BY THE PIPE MANUFACTURER.
- DRAINAGE MANHOLES SHALL REINFORCED CONCRETE WITH BLACK COATED CAST IRON MANHOLE COVERS AND FRAMES. THE MANHOLE COVERS SHALL HAVE APPROPRIATE IDENTIFICATION MARKER.
- ALL INTERNAL MANHOLE SURFACES SHALL BE COATED WITH TWO COATS OF APPROVED BITUMINOUS PAINT. ONE COAT OF SAME PAINT SHALL BE APPLIED TO EXTERNAL SURFACES.
- SLOPES OF SOIL AND WASTE PIPES SHALL BE 1 - 2% OTHERWISE INDICATED ON THE LAYOUTS.
- VENT PIPES THROUGH ROOF SHALL HAVE RIGID SUPPORTS AND BE MADE WATER TIGHT WITH THE ROOF BY PROPER FLASHING, WITH VENT COWL.
- ALL DRAINAGE PIPE WORK SHALL BE TESTED IN ACCORDANCE WITH BS 5572 AND BS 8301. 06. SANITARY FIXTURES SHALL BE AS SPECIFIED IN SPEC
- ALL PIPES SHALL GO THROUGH $\frac{1}{3}$ - $\frac{2}{3}$ OF THE TOTAL BEAM LENGTH FROM COLUMN TO COLUMN.

HVAC NOTES

H.V.A.C. CONTRACTOR SHALL COORDINATE WITH ALL TRADES BUT NOT LIMITED TO THE FOLLOWING:

STRUCTURAL SUPPORTS FOR ROOF TOP MOUNTED CONDENSING UNITS, AND EXHAUST FANS

- A. OPENING IN WALLS, FLOOR, AND ROOF.
- B. ALL DIFFUSER AND REGISTER LOCATIONS.
- C. EQUIPMENT WEIGHTS WHEN SUSPENDED FROM CEILING OR MOUNTED ON ROOF.
- D. DRAIN FROM EQUIPMENT AT THE ROOF.
- E. ALL THERMOSTAT LOCATIONS.
- L ALL EQUIPMENT CAPACITY AND SPECIFICATION SHALL BE AS NOTED ON DRAWINGS.
- C ALL EQUIPMENT SHALL BE PROVIDED WITH VIBRATION ABSORBER.
- F THE CONTRACTOR SHALL BE COORDINATE THE AIR CONDITIONING EQUIPMENT, DUCT WORKS, PIPING AND EXHAUST FANS WITH STRUCTURAL & ARCHITECTURAL DRAWINGS.
- C THE MECHANICAL CONTRACTOR MUST COORDINATE THE FINAL LOCATION OF THE OPENINGS THROUGH CEILINGS, FLOORS, WALLS & ROOF WITH ARCHITECTURAL, ELECTRICAL, AND STRUCTURAL SHOP DRAWINGS AND ENGINEERS.
- L COORDINATE ALL DIFFUSERS AND GRILLES LOCATIONS WITH REFLECTED CEILING PLANS, LIGHT FITTINGS, AND FALSE CEILING ACCESS PANELS.
- F CONTROL COMPONENTS SHOULD BE ACCESSIBLE.
- L ALL EQUIPMENT SHALL BE PROVIDED WITH STANDARD CONTROLS, INDICATORS AND ETC. NEEDED FOR THE EFFICIENT OPERATION OF AC SYSTEM. FCU ROOM THERMOSTAT SHOULD BE INSTALLED NEAR THE RETURN. EXACT LOCATION TO BE CO-ORDINATED WITH CIVIL WORKS. PROVIDE NECESSARY FIRE DAMPER (DUCT PASSING THRU WALL OR CONCRETE FLOOR SLAB) AS REQUIRED.
- C ALL CONTROL INSTRUMENTS AND MECHANICAL EQUIPMENT EXPOSED TO OUTSIDE WEATHER CONDITIONS SHALL BE WEATHER PROOF ACCORDING TO MANUFACTURER'S RECOMMENDATIONS.
- L ALL NEEDED SUPPORTS FOR EQUIPMENT MOUNTING ARE TO BE PROVIDED AND INSTALLED BY THE CONTRACTOR BASED ON OFFICE APPROVAL .
- L ALL STEEL MATERIALS USED FOR MOUNTING BASES SUPPORTS, BRACKETS AND ETC. SHALL BE PAINTED WITH DEPENDABLE PROTECTIVE COATING AGAINST RUST AND CORROSION.
- F ALL CONDENSATE DRAIN PIPE SHALL BE UPVC PIPE AND TAPPED TO THE NEAREST DRAINAGE SYSTEM WITH TUN DISH CONNECTION.
- L THE CONTRACTOR SHALL BE RESPONSIBLE TO ACHIEVE THE NOISE LEVEL LESS THAN 35 DPa.
- C PROVIDE DOOR LOUVERS, GRILLS AND UNDERCUT WHERE REQUIRED.
- F THE MECHANICAL CONTRACTOR SHALL PROVIDE ELECTRICAL WIRING OF THE HVAC PLANT AND REMOTE SENSORS/ DETECTORS UP TO THE ISOLATORS PROVIDED BY THE ELECTRICAL CONTRACTORS.
- I THE MECHANICAL CONTRACTOR SHALL BE RESPONSIBLE FOR THE MOTOR CONTROL, REMOTE SWITCH, STARTER ISOLATORS AND CONTROL PANELS .
- C THE CONTRACTOR WILL TURN OVER ALL MECHANICAL EQUIPMENT MANUALS AND INSTRUCTION, OVER TO THE USER AT THE COMPLETION OF CONS

DESIGN DATA FOR SEPTIC TANK

- NO. OF USERS: APPROX. 50
- PER CAPACITY CONSUMPTION OF WATER: 135 LPCD
- ASSUMING 70% OF WATER CONSUMPTION TRANSFORMED INTO SEWAGE, SEWAGE FLOW RATE: 94.5 LPCD
- PORTABLE PEAK DISCHARGE FOR 50 USERS: 108 LPM
- SURFACE AREA OF THE TANK REQUIRED FOR EVERY 10LPM OF PEAK FLOW AT A TEMP 25DEGC: 0.92 SQ. M.
- MINIMUM DEPTH OF SEDIMENTATION: 300MM
- PER CAPITA SUSPENDE SOLIDS ENTERING THE TANK: 70G/DAY
- PER CAPACITY REQUIRED FOR SLUDGE DIGESTION: 0.033CU.M
- PER CAPITA VOLUME OF DIGESTED SLUDGE: 0.00021CU.M/DAY
- DETENTION TIME: 36HRS
- SEPTIC TANK CLEANING INTERVAL: 1 YEAR
- SEPTIC TANK CAPACITY
- TANK VOLUME: 7.0875CU.M
- SLUDGE STORAGE CAPACITY: 3.8325CU.M
- TOTAL CAPACITY OF SEPTIC TANK: 10.92CU.M
- WITH THE PROVISION OF FUTURE EXPANSION, KEEPING 20% MARGIN, THE TOTAL CAPACITY: 14CU.M
- SEPTIC TANK SIZE
- ASSUME THE LIQUID DEPTH: 1.4M
- PLAN AREA OF THE TANK: 10M
- LENGTH TO WIDTH RATION: 2
- WIDTH OF THE TANK: 2.3M
- LENGTH OF THE TANK: 4.6M
- FREE BOARD: 0.4M
- CHECK FOR SURFACE AREA
- SURFACE AREA REQUIRED: 9.936SQ.M
- SURFACE AREA PROVIDED: 10.58SQ.M OK
- SLUDGE DEPTH REQUIRED: 0.23393195M
- SLUDGE DEPTH PROVIDED: 0.37 OK
- SIZE OF SEPTIC TANK: 4.6M L X 2.3M W X 1.4M SWD + 0.4M F.B.

	OWNER	DRAWN BY:		PROJECT TITLE	SHEET CONTENT	SHEET NO.
	TECHNOLOGICAL UNIVERSITY OF THE PHILIPPINES CAVITE CAMPUS	PAM		PROPOSED ENGINEERING AND ARCHITECTURE BUILDING	GENERAL NOTES HVAC NOTES	P1 P9
		REGISTERED MASTER PLUMBER				
		REG NO:	DATE ISSUED:			
DATE EXPIRED:	PLACE ISSUED:	REV NO.:	DATE:	LOCATION: CQT. AVE. BRGY. SALAWAG, DASMARIÑAS CITY, CAVITE, PHILIPPINES		
	PTR NO:	TIN NO:				

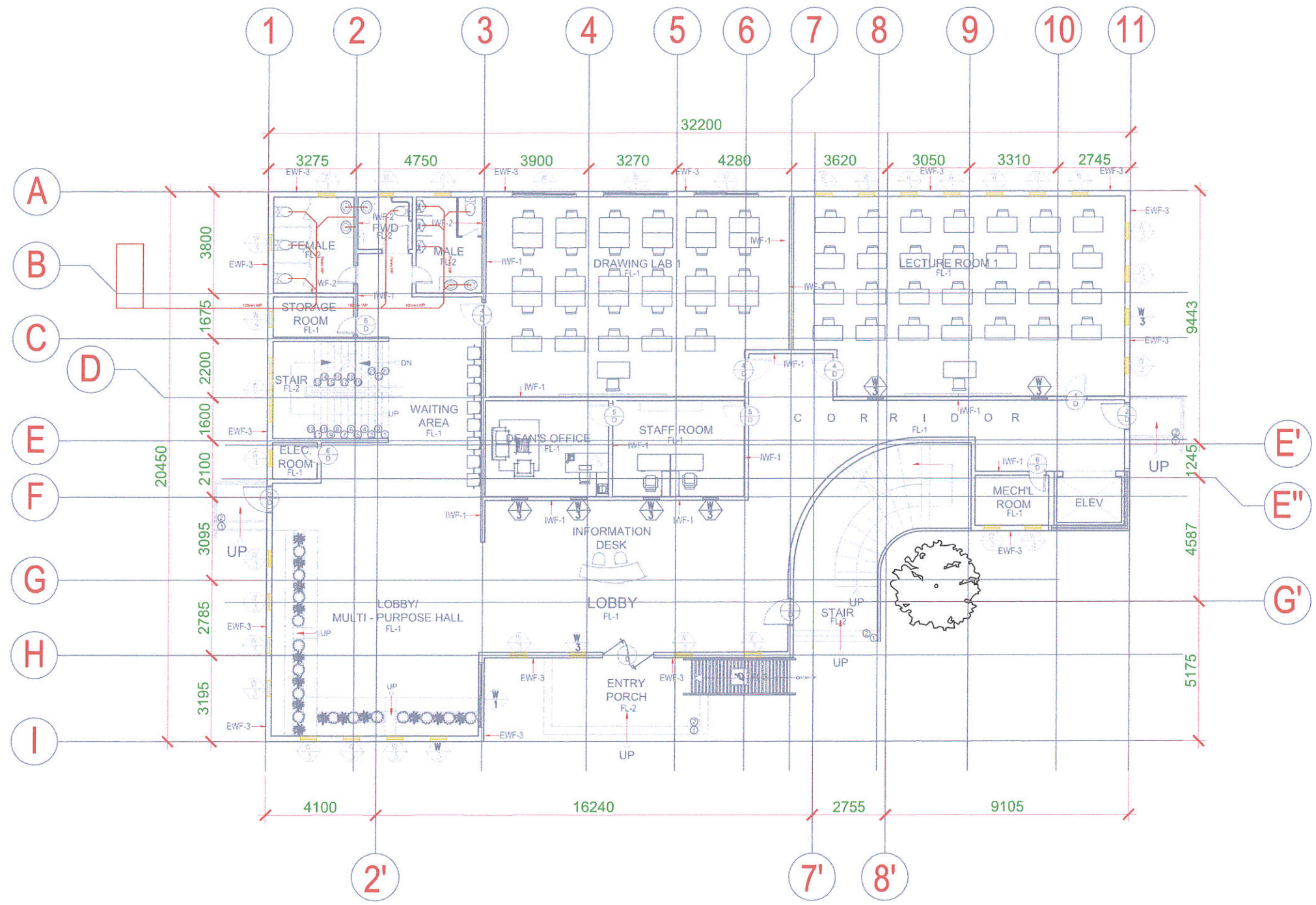

1
P-3

ENGINEERING AND ARCHITECTURE BUILDING
GROUND FLOOR WATER SUPPLY PLAN

SCALE 1:100 M

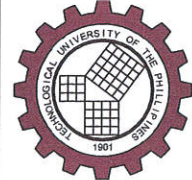
 TUP CAVITE	OWNER	REGISTERED MASTER PLUMBER REG NO: _____ DATE ISSUED: _____ DATE EXPIRED: _____ PLACE ISSUED: _____ PTR NO: _____ TIN NO: _____	DRAWN BY:	PROJECT TITLE PROPOSED ENGINEERING AND ARCHITECTURE BUILDING LOCATION: CQT. AVE. BRGY. SALAWAG, DASMARIÑAS CITY, CAVITE, PHILIPPINES	SHEET CONTENT	SHEET NO. P2 P9
	TECHNOLOGICAL UNIVERSITY OF THE PHILIPPINES CAVITE CAMPUS		PAM REV NO.: _____ DATE: _____		GROUND FLOOR WASTE WATER PLAN	

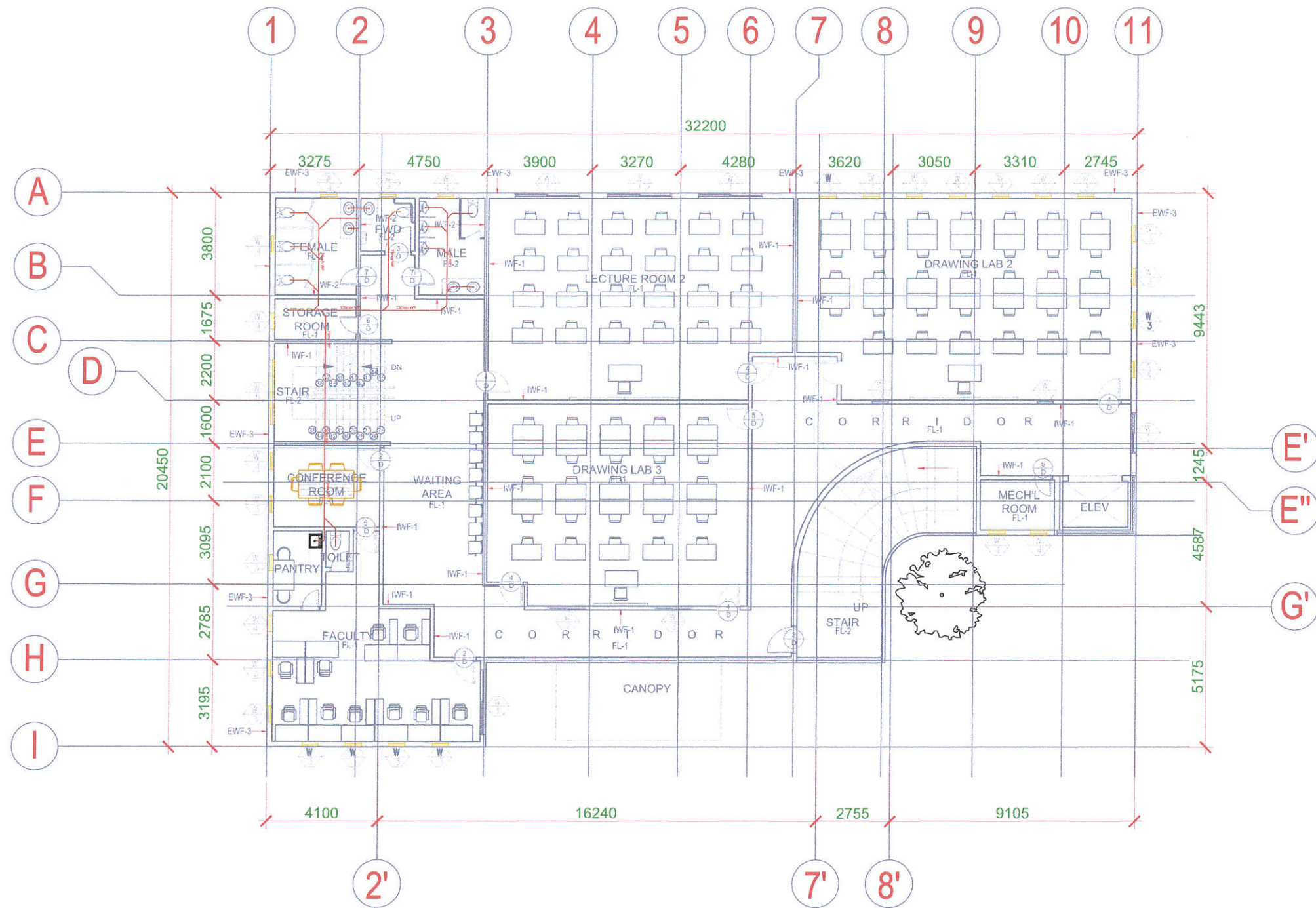

1
R-3

ENGINEERING AND ARCHITECTURE BUILDING
SECOND FLOOR WASTE WATER PLAN
 SCALE 1:100 M

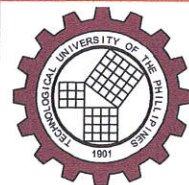

TUP
CAVITE

OWNER
 TECHNOLOGICAL UNIVERSITY OF THE PHILIPPINES
 CAVITE CAMPUS

REGISTERED MASTER PLUMBER
 REG NO:
 DATE EXPIRED:
 PTR NO:

DATE ISSUED:
 PLACE ISSUED:
 TIN NO:

DRAWN BY:
 PAM
 REV NO.:
 DATE:

PROJECT TITLE
 PROPOSED ENGINEERING
 AND ARCHITECTURE
 BUILDING
 LOCATION: CQT. AVE. BRGY. SALAWAG, DASMARIÑAS CITY, CAVITE, PHILIPPINES

SHEET CONTENT
 SECOND FLOOR WASTE
 WATER PLAN

SHEET NO.
 P3
 P9

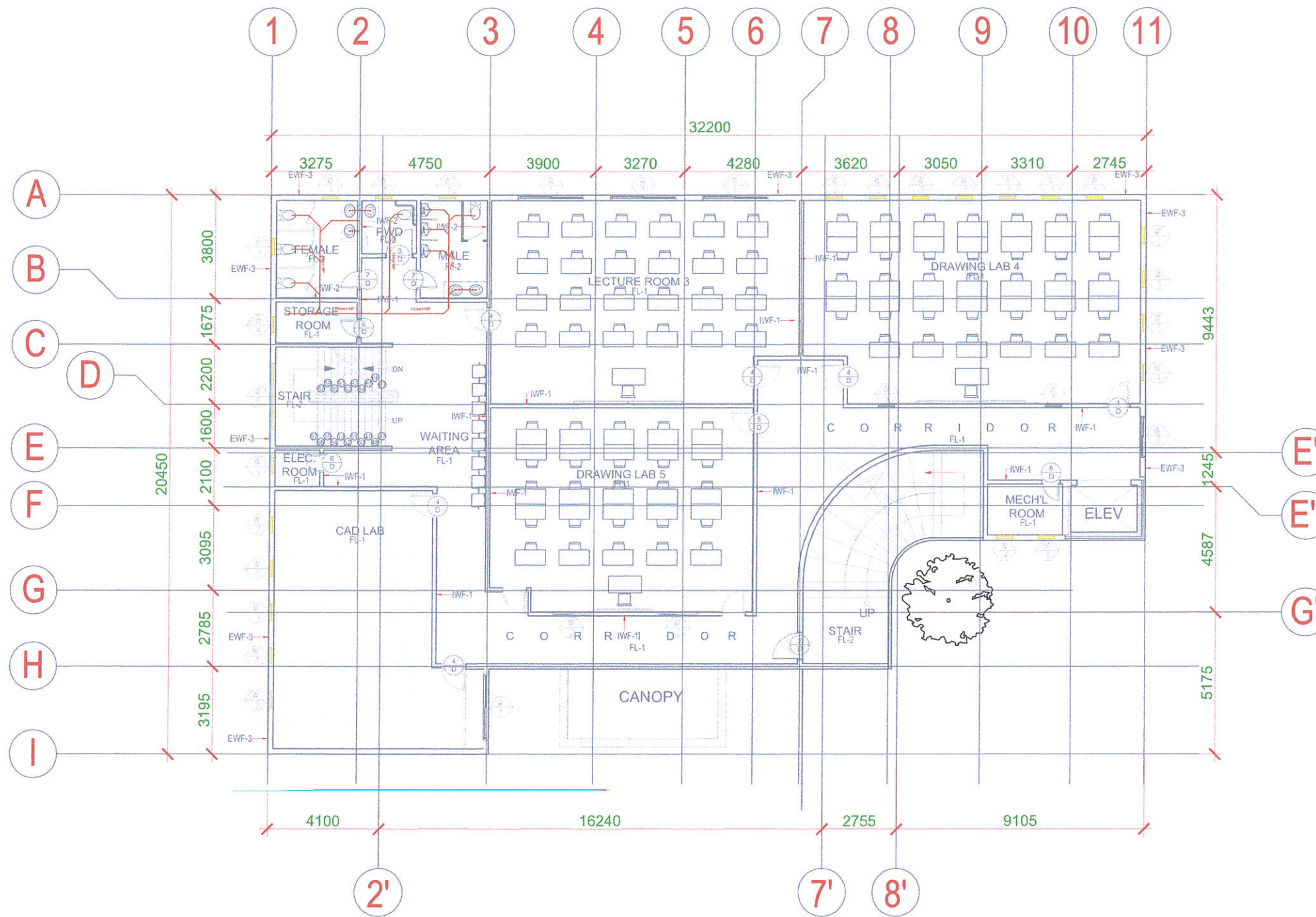

1
A-3
ENGINEERING AND ARCHITECTURE BUILDING
TYPICAL 3RD TO 5TH FLOOR WASTE WATER PLAN
SCALE 1:100 M

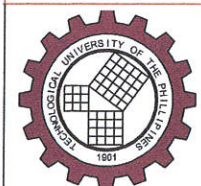

TUP
CAVITE

OWNER
TECHNOLOGICAL UNIVERSITY OF THE PHILIPPINES
CAVITE CAMPUS

REGISTERED MASTER PLUMBER
REG NO: _____ DATE ISSUED: _____
DATE EXPIRED: _____ PLACE ISSUED: _____
PTR NO: _____ TIN NO: _____

DRAWN BY:
PAM
REV NO: _____ DATE: _____

PROJECT TITLE
PROPOSED ENGINEERING
AND ARCHITECTURE
BUILDING
LOCATION: CQT. AVE. BRGY. SALAWAG, DASMARIÑAS CITY, CAVITE, PHILIPPINES

SHEET CONTENT
TYPICAL 3RD TO 5TH FLOOR
WASTE WATER PLAN

SHEET NO.
P4
P9

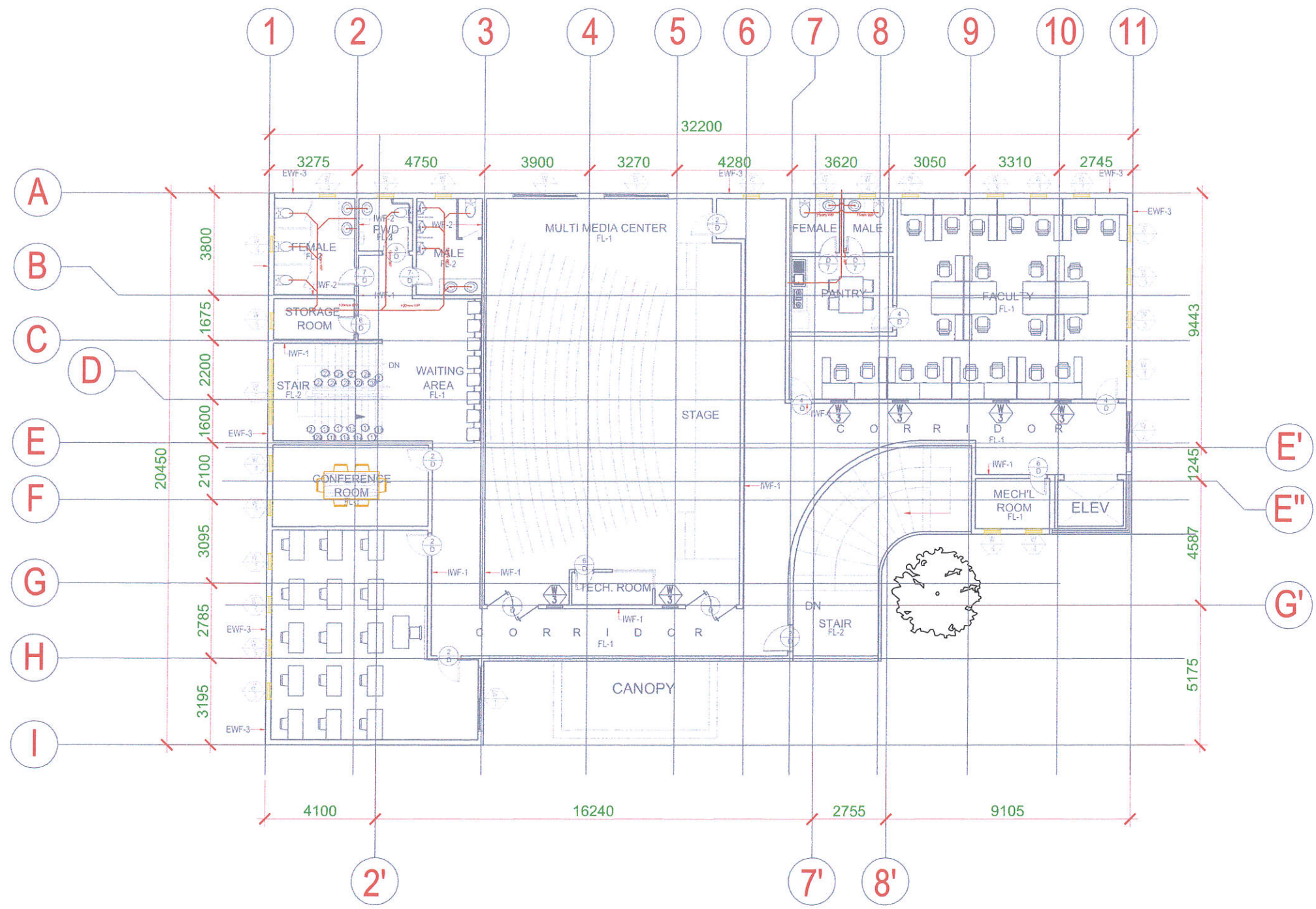

ENGINEERING AND ARCHITECTURE BUILDING
1 6TH FLOOR WASTE WATER PLAN
 A-3 SCALE 1:100 M

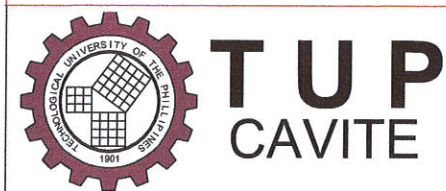

OWNER
 TECHNOLOGICAL UNIVERSITY OF THE PHILIPPINES
 CAVITE CAMPUS

REGISTERED MASTER PLUMBER
 REG NO:
 DATE EXPIRED:
 PTR NO:

DRAWN BY:
 PAM
 REV NO.:
 DATE:

PROJECT TITLE
 PROPOSED ENGINEERING
 AND ARCHITECTURE
 BUILDING
 LOCATION: CQT. AVE. BRGY. SALAWAG, DASMARIÑAS CITY, CAVITE, PHILIPPINES

SHEET CONTENT
 6TH FLOOR WASTE WATER PLAN

SHEET NO.
 P5
 P9

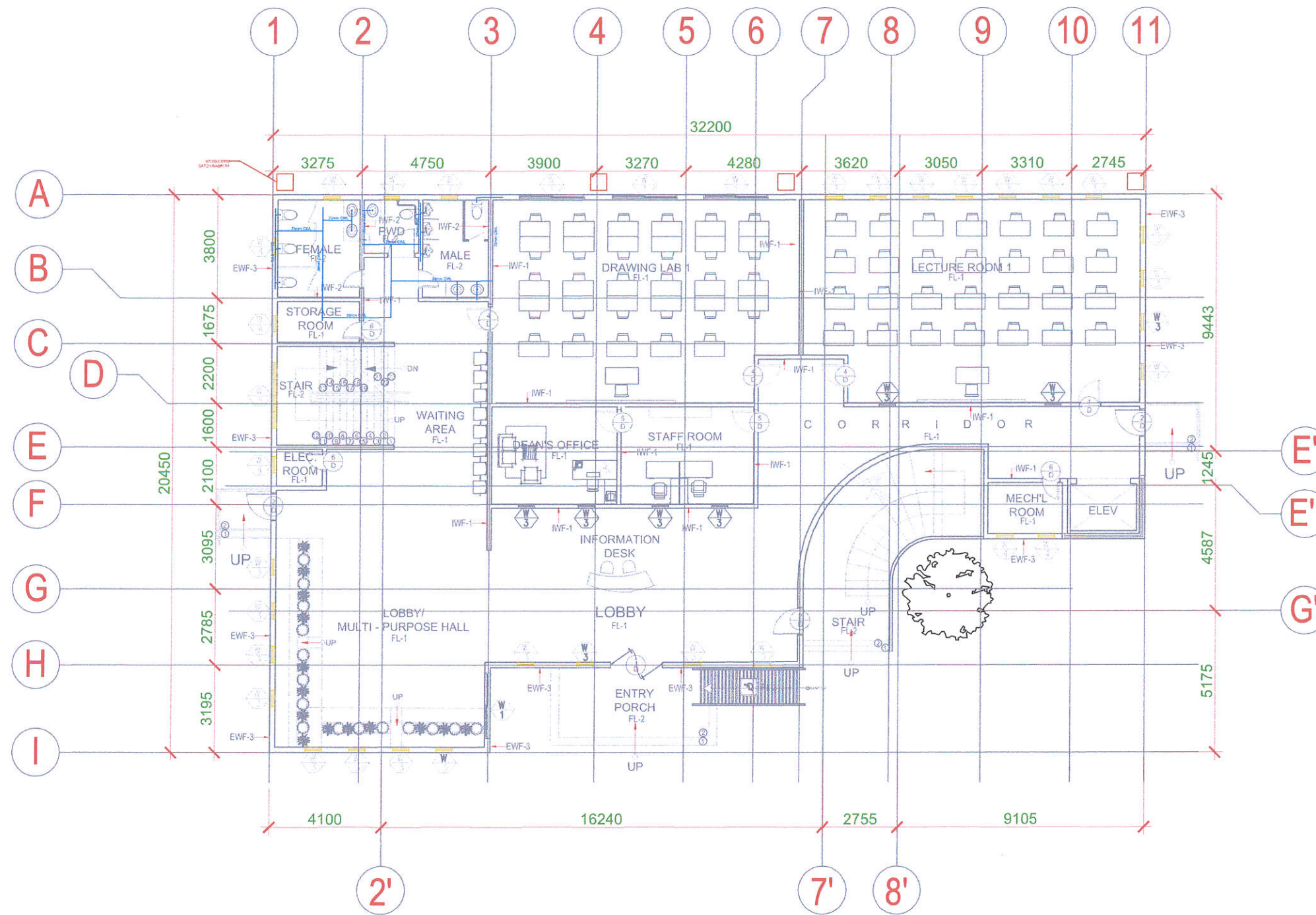

ENGINEERING AND ARCHITECTURE BUILDING
1
GROUND FLOOR WATER SUPPLY PLAN
 P-3 SCALE 1:100 M

 TUP CAVITE	OWNER	REGISTERED MASTER PLUMBER	DRAWN BY:	PROJECT TITLE	SHEET CONTENT	SHEET NO.
	TECHNOLOGICAL UNIVERSITY OF THE PHILIPPINES CAVITE CAMPUS		PAM	PROPOSED ENGINEERING AND ARCHITECTURE BUILDING	GROUND FLOOR WATER SUPPLY PLAN	P6
	REG NO: DATE EXPIRED: PTR NO:	DATE ISSUED: PLACE ISSUED: TIN NO:	REV NO.: DATE:	LOCATION: CQT. AVE. BRGY. SALAWAG, DASMARIÑAS CITY, CAVITE, PHILIPPINES		P9

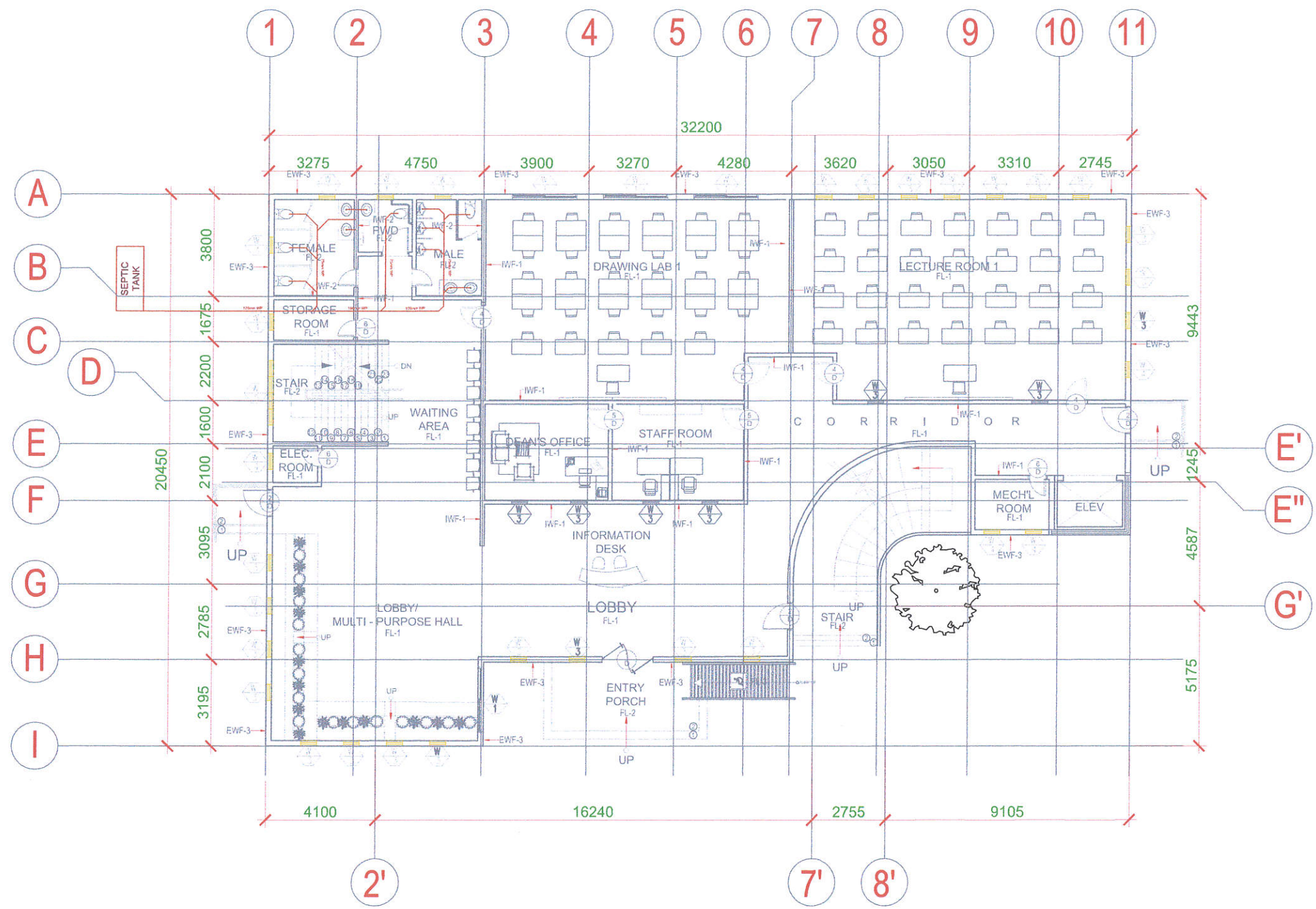

1
P-3

ENGINEERING AND ARCHITECTURE BUILDING
GROUND FLOOR WATER SUPPLY PLAN
 SCALE 1:100 M

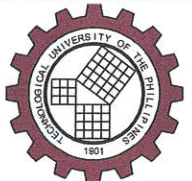
 TUP CAVITE	OWNER	REGISTERED MASTER PLUMBER	DRAWN BY:	PROJECT TITLE	SHEET CONTENT	SHEET NO.
	TECHNOLOGICAL UNIVERSITY OF THE PHILIPPINES CAVITE CAMPUS		PAM	PROPOSED ENGINEERING AND ARCHITECTURE BUILDING	SECOND FLOOR WASTE WATER PLAN	P7
	REG NO: DATE EXPIRED: PTR NO:	DATE ISSUED: PLACE ISSUED: TIN NO:	REV NO: DATE:	LOCATION: CQT. AVE. BRGY. SALAWAG, DASMARIÑAS CITY, CAVITE, PHILIPPINES		P9

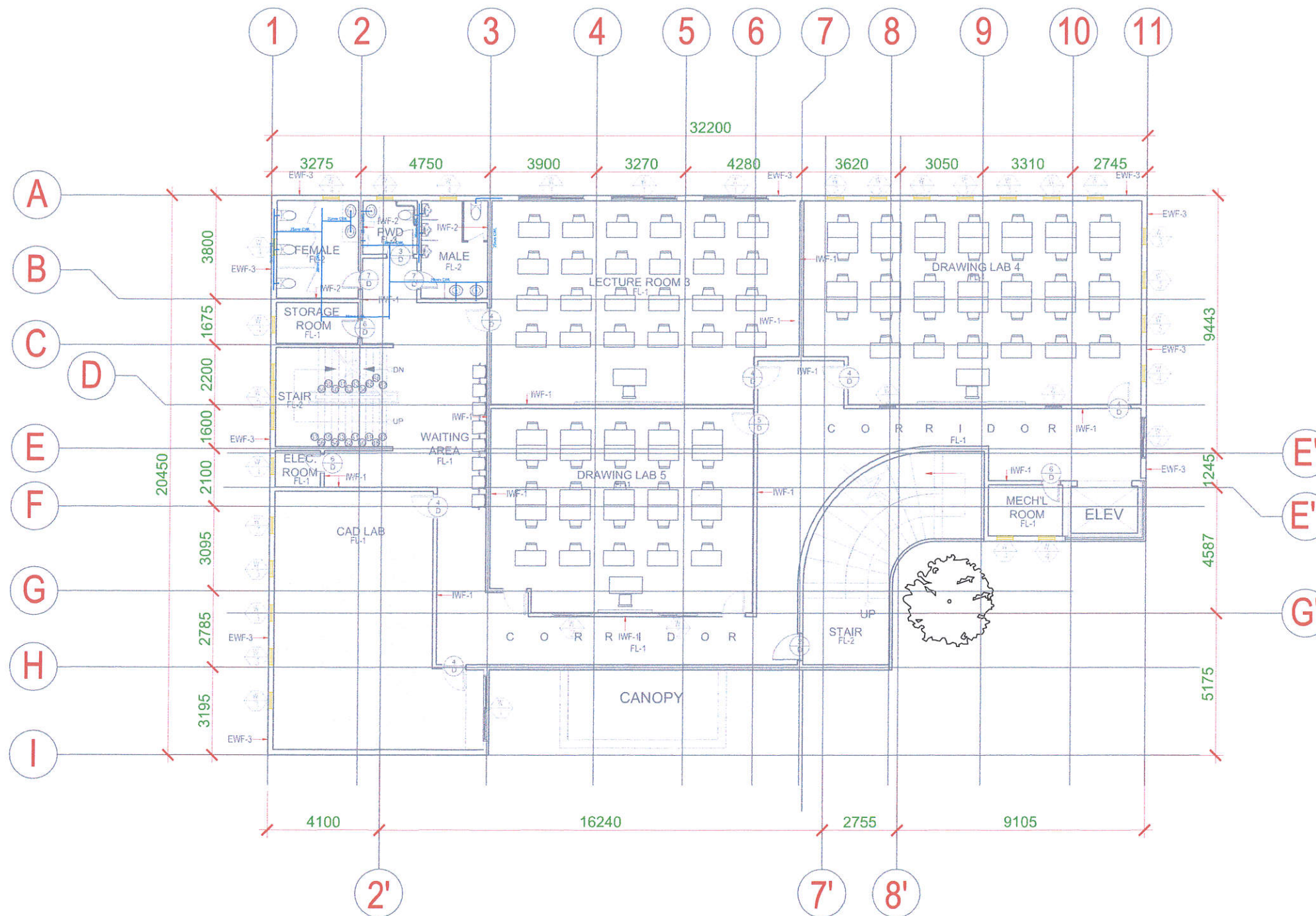

ENGINEERING AND ARCHITECTURE BUILDING
1 TYPICAL 3RD TO 5TH WATER SUPPLY PLAN
 SCALE 1:100 M

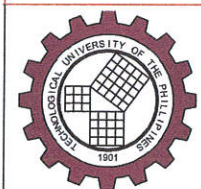

TUP
CAVITE

OWNER
 TECHNOLOGICAL UNIVERSITY OF THE PHILIPPINES
 CAVITE CAMPUS

REGISTERED MASTER PLUMBER
 REG NO: _____ DATE ISSUED: _____
 DATE EXPIRED: _____ PLACE ISSUED: _____
 PTR NO: _____ TIN NO: _____

DRAWN BY:
 PAM
 REV NO.: _____ DATE: _____

PROJECT TITLE
 PROPOSED ENGINEERING
 AND ARCHITECTURE
 BUILDING
 LOCATION: CQT. AVE. BRGY. SALAWAG, DASMARIÑAS CITY, CAVITE, PHILIPPINES

SHEET CONTENT
 TYPICAL 3RD TO 5TH WATER
 SUPPLY PLAN

SHEET NO.
 P8
 P9

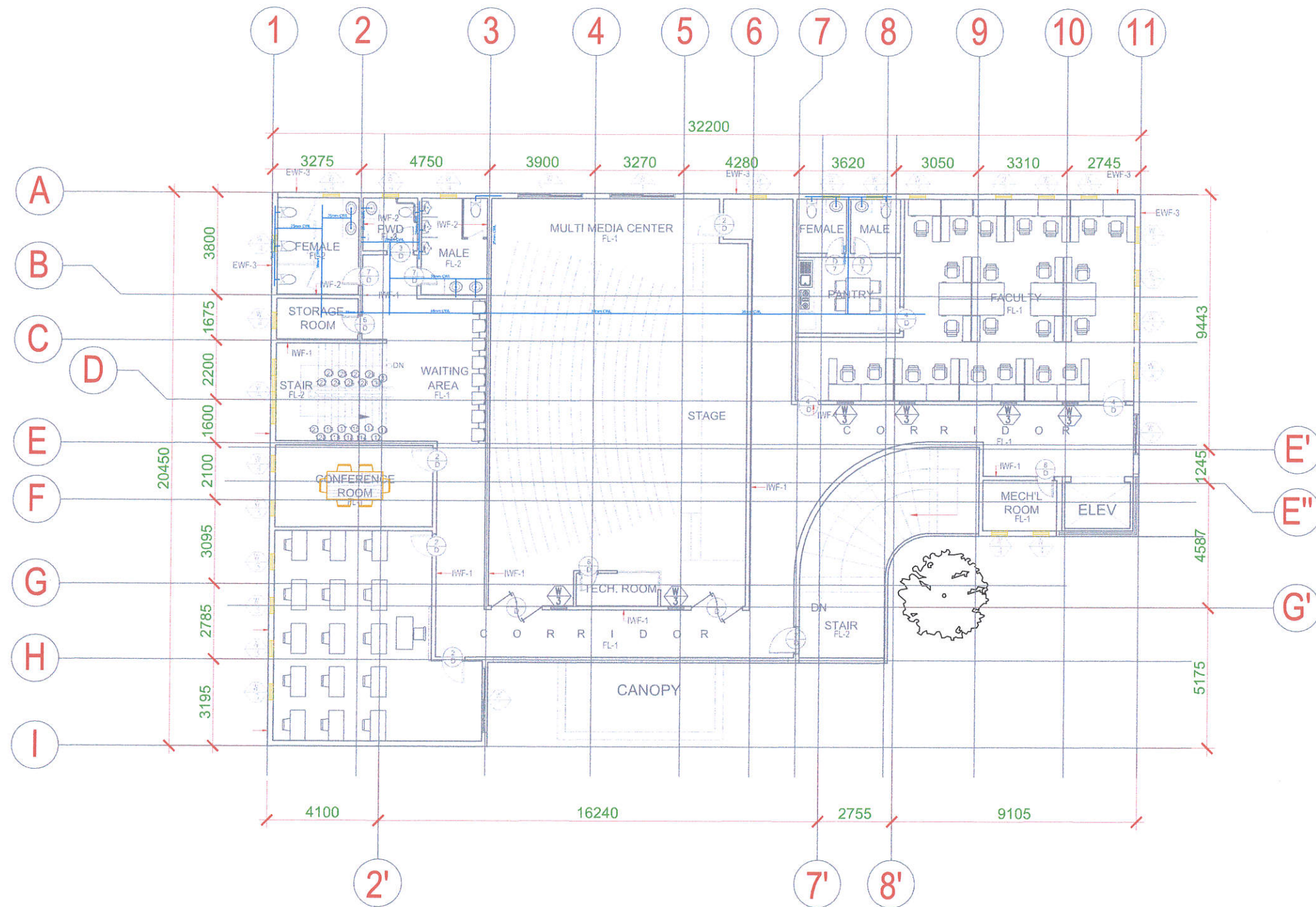

1
A-3
ENGINEERING AND ARCHITECTURE BUILDING
6TH FLOOR WATER SUPPLY PLAN
SCALE 1:100 M

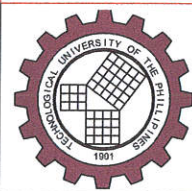

TUP
CAVITE

OWNER
TECHNOLOGICAL UNIVERSITY OF THE PHILIPPINES
CAVITE CAMPUS

REGISTERED MASTER PLUMBER
REG NO: _____ DATE ISSUED: _____
DATE EXPIRED: _____ PLACE ISSUED: _____
PTR NO: _____ TIN NO: _____

DRAWN BY:
PAM
REV NO: _____ DATE: _____

PROJECT TITLE
PROPOSED ENGINEERING
AND ARCHITECTURE
BUILDING
LOCATION: CQT. AVE. BRGY. SALAWAG, DASMARIÑAS CITY, CAVITE, PHILIPPINES

SHEET CONTENT
6TH FLOOR WATER
SUPPLY PLAN

SHEET NO.
P9
P9

GENERAL NOTES

- ALL ELECTRICAL WORKS HEREIN SHALL BE DONE IN ACCORDANCE WITH THE PROVISION OF THE LATEST EDITION OF THE PHILIPPINE ELECTRICAL CODE (PEC), THE LAWS OR ORDINANCES OF THE LOCAL ENFORCING AUTHORITY AND THE REQUIREMENTS OF THE LOCAL POWER COMPANY AND TELEPHONE COMPANY.
- INCOMING PRIMARY SERVICE POWER SHALL BE 34.5 kV, 30, 4 -WIRES 60 HZ SYSTEM AND THE BUILDING UTILIZATION VOLTAGE SHALL BE 400, 4- WIRES WITH GROUND, 60 HZ SYSTEM.
- CONDUIT TO BE USED FOR DIFFERENT ELECTRICAL SYSTEMS SHALL BE AS FOLLOWS UNLESS OTHERWISE INDICATED IN THE PLAN
 - POWER SYSTEM

EMBEDDED	EMT / RSC
CONCEALED ON FLASE CEILING AND DRY WALL	PVC
INSIDE EE ROOM	PVC
	EMT / RSC
 - MAIN FEEDER, SERVICE ENTRANCE EXPOSED

	EMT / RSC
--	-----------

* USE COMPRESSION TYPE FITTINGS FOR EMT
- SMALLEST BRANCH CIRCUIT WERE SHALL BE 3.5 MM² THHN FOR POWER AND LIGHTING SYSTEM IN RACEWAY 1/2" TRADE SIZE CONDUIT, WIRE SHALL BE INSULATED FOR 600 VOLTS
- WHENEVER NECESSARY FULLBOX OF PROPER SIZE AND DIMENSION SHALL BE PROVIDED ALTHOUGH NOT INDICATED IN THE PLAN, ALL BOXES SHALL BE PROVIDED WITH METAL PLATE COVER.
- ALL LIGHT CONTROLLED SWITCHES SHALL BE RATED 15 AMPS, 220 AC ONLY. SWITCHES SHALL BE INSTALLED FOR OPERATION WITH HORIZONTAL MOTION.
- ALL PANELBOARDS SHALL BE PROVIDED WITH MULTIPLE TERMINAL LUGS FOR NEUTRAL AND SOLID GROUNDING, CONNECTED TO BUILDING GROUNDING SYSTEM LOCATED AT LOWEST LEVEL OF THE BUILDING.
- ALL BRANCH CIRCUIT HOMERUN FOR POWER AND LIGHTING SHALL NOT BE COMBINED IN THE SAME RACEWAY.
- FOR EACH SPARE CIRCUIT BREAKER IN PANEL BOARD PROVIDE 1/2", RACEWAY TERMINATED IN 100 mm DEEP TYPE SQUARE BOX WITH COVER BELOW CEILING SLAB AND SHALL BE PROVIDED WITH ALL PULL WIRES OR AS INDICATED ON LOAD SCHEDULE.
- ALL METALLIC CONDUIT, CABINET, BOXES, AND EQUIPMENT SHALL BE PROPERLY GROUNDING AND BONDED.
- ALL MATERIALS TO BE USED SHALL BE NEW AND APPROVED FOR THE LOCATION AND PURPOSES.
- ALL MOLDED CASE CIRCUIT BREAKERS FOR MOTORS SHALL BE INDUSTRIAL TYPE.
- BOXES SHALL BE MADE OF CODE GAUGE STEEL WITH ZINC CHROMATE PROTECTION.
- ALL RECEPTACLE OUTLET SHALL BE PROPERLY GROUNDING TO THE BOX BY MEANS OF GROUNDING LUGS.
- MOUNTING HEIGHT NOT SHOWN SHALL BE COLOR CODED ARE AS FOLLOWS:

a. LIGHT SWITCH	-1.20 M ABOVE FINISH FLOOR
b. CONVENIENCE OUTLET	-0.30 M ABOVE FINISH FLOOR
c. PANELBOARD	-1.50 M ABOVE FINISH FLOOR
- ALL WIRES AND CABLES SHALL BE COLOR CODED AS FOLLOWS:

PHASE A	RED
PHASE B	YELLOW
PHASE C	BLUE
NEUTRAL	WHITE
GROUND	GREEN
- ALL CONDUIT BOXES AND SUPPORT SHALL BE COLOR CODED AS FOLLOWS:

a. POWER & LIGHTING SYSTEM	GRAY
----------------------------	------
- CONDUIT SLEEVES AND FLOOR SLOT PENETRATION THROUGH ELECTRICAL, AND TELEPHONE ROOM WALLS / CLOSET SPACES SHALL BE PROPERLY SEALED-OFF WITH THE FIRE RETARDANT MATERIALS TO MAINTAIN FIRE RESISTIVE RATINGS OF THE FLOOR OPENING.
- THE ELECTRICAL CONTRACTOR SHALL BE SECURE ALL WIRING PERMITS AND ALL FEES REQUIRED FOR THE WORK AND SHALL FURNISH TO THE OWNER THROUGH THE ENGINEERS FINAL CERTIFICATES OF ELECTRICAL INSPECTION AND APPROVAL FROM PROPER GOVERNMENT AUTHORITIES FOR COMPLETE WORK.
- THE ELECTRICAL CONTRACTOR SHALL REFER TO ARCHITECTURAL AND INTERIOR DESIGN PLAN FOR THE EXACT LOCATION AND MOUNTING HEIGHT OF ALL VISIBLE WIRING DEVICES, FIXTURES AND THE LINES.
- THE ELECTRICIAN, CONTRACTOR SHALL PROVIDE SHOP DRAWING IN ANY CHANGES IN MOUNTING HEIGHT OR LOCATION FOR THE APPROVAL OF THE ARCHITECT OR ENGINEER.
- IN CASE ANY CONFLICT BETWEEN PLANS OF DIFFERENT TRADES, ACTUAL SITE CONDITIONS OR SPECIFICATIONS IS EVIDENT, THE ELECTRICAL CONTRACTOR SHALL IMMEDIATELY VERIFY THE ELECTRICAL CONSULTANT.
- ALL ELECTRICAL WORKS HEREIN SHALL BE DONE UNDER THE DIRECT AND IMMEDIATE SUPERVISION OF A DULY QUALIFIED ELECTRICAL ENGINEER.

ALL MOUNTING HEIGHTS ARE SUBJECT TO THE APPROVAL OF THE ARCHITECT / OWNER
- ALL WIRES SHALL BE COPPER AND THERMOPLASTIC INSULATED TYPE "THW" UNLESS OTHERWISE INDICATED IN THE PLAN. THE MINIMUM SIZE OF WIRE FOR POWER AND LIGHTING CIRCUIT HOME RUN SHALL BE 3.5mm² AND INSULATED FOR 600 VOLTS SMALLEST RACEWAY SHALL BE 15mm diameter TRADE/ NOMINAL SIZE
- ALL MATERIALS TO BE USED SHALL BE BRAND NEW AND APPROVED TYPE FOR THE PARTICULAR LOCATION AND PURPOSE USAGE.
- GROUNDING SYSTEM SHALL BE PROVIDED TO ALL LIGHTING AND POWER CIRCUIT AS PER PHILIPPINE ELECTRICAL CODE (PEC).
- MOUNTING HEIGHT OF WIRING DEVICES SHALL BE AS FOLLOWS:

1 GENERAL NOTES
E-1 SCALE NTS

GROUND FLOOR PLAN	
[Symbol]	FLAT PANEL LIGHT
[Symbol]	CEILING LIGHT
[Symbol]	WATER PROOF OUTLET
[Symbol]	FLOOR MOUNTED OUTLET
[Symbol]	EMERGENCY OUTLET
[Symbol]	EMERGENCY OUTLET
[Symbol]	SPOT LIGHT
[Symbol]	WALL SCONCE
[Symbol]	COVE LIGHT
[Symbol]	DOWN LIGHT
[Symbol]	SWITCH
[Symbol]	PENDANT LIGHT
[Symbol]	CIRCUIT NUMBER
[Symbol]	POWER PANEL
[Symbol]	THREE - GANG OUTLET
[Symbol]	TWO - GANG OUTLET
[Symbol]	WATER PROOF OUTLET
[Symbol]	FLOOR MOUNTED OUTLET
[Symbol]	EMERGENCY OUTLET
[Symbol]	CIRCUIT NUMBER
[Symbol]	POWER PANEL
[Symbol]	AIR CONDITIONING OUTLET

2 LEGENDS AND SYMBOLS
E-1 SCALE NTS

SHEET NO.	SHEET CONTENT
E-01	GENERAL NOTES, LEGENDS AND SYMBOLS, VICINITY MAP
E-02	GROUND FLOOR LIGHTING LAYOUT
E-03	SECOND FLOOR LIGHTING LAYOUT
E-04	TYPICAL THIRD TO FIFTH FLOOR LIGHTING LAYOUT
E-05	SIXTH FLOOR LIGHTING LAYOUT
E-06	GROUND FLOOR POWER LAYOUT
E-07	SECOND FLOOR POWER LAYOUT
E-08	TYPICAL THIRD TO FIFTH FLOOR POWER LAYOUT
E-09	SIXTH FLOOR POWER LAYOUT
E-10	SCHEDULE OF LOADS
E-11	POWER RISER DIAGRAM

3 DRAWING INDEX
E-1 SCALE NTS



4 VICINITY MAP
E-1 SCALE NTS



OWNER
TECHNOLOGICAL UNIVERSITY OF THE PHILIPPINES
CAVITE CAMPUS

PROFESSIONAL ELECTRICAL ENGINEER
REG NO.:
DATE EXPIRED:
PTR NO:

DATE ISSUED:
PLACE ISSUED:
TIN NO:

DRAWN BY:
REV NO.:
DATE:

PROJECT TITLE
PROPOSED ENGINEERING AND ARCHITECTURE BUILDING
LOCATION: CQT. AVE. BRGY. SALAWAG, DASMARIÑAS CITY, CAVITE, PHILIPPINES

SHEET CONTENT

SHEET NO.
E
1

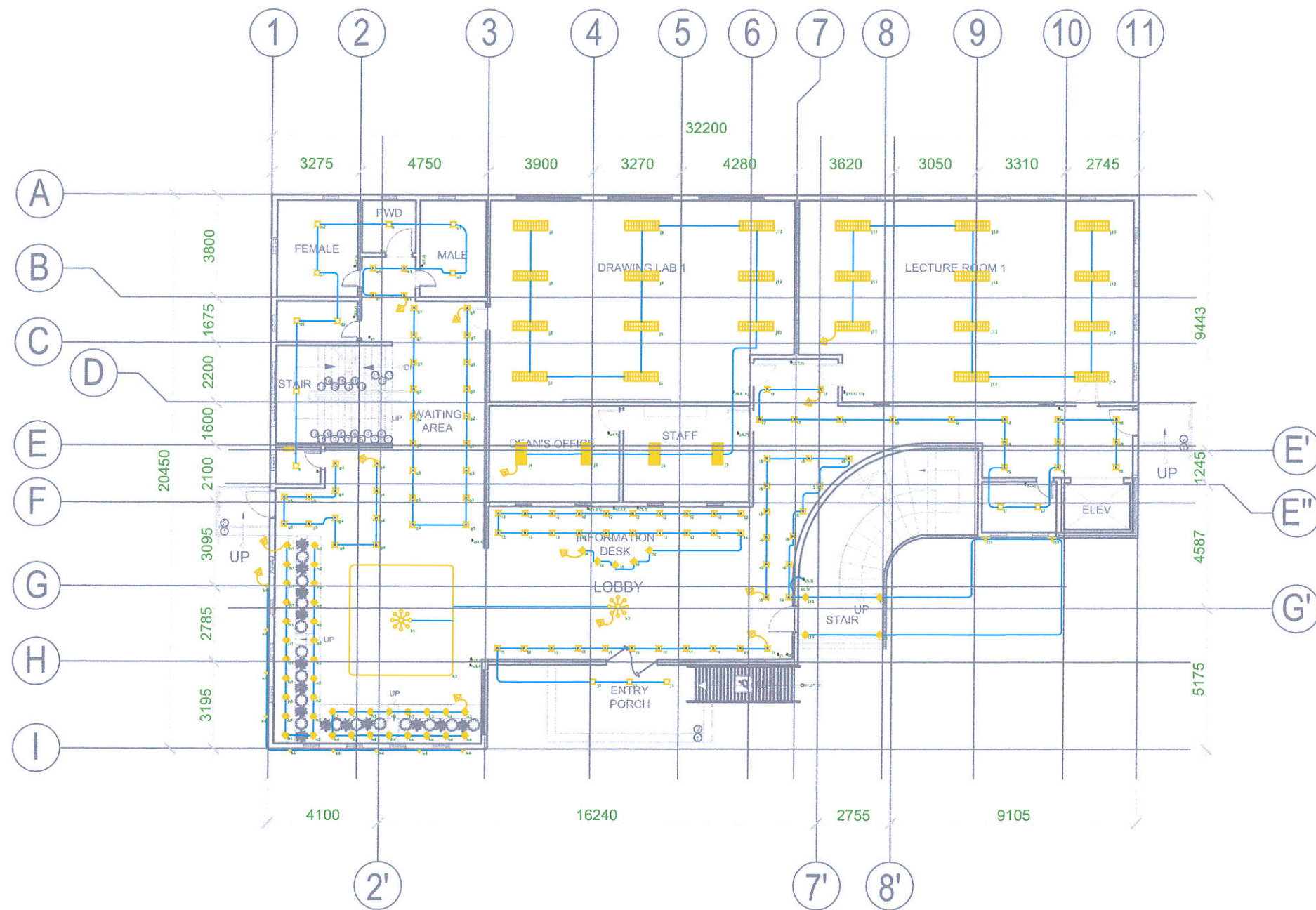

ELECTRICAL LEGEND	
	FLAT PANEL LIGHT
	CEILING LIGHT
	LOUVER
	PIN LIGHT
	CHANDELIER
	RECESSED LIGHT
	SPOT LIGHT
	WALL SCONCE
	COVE LIGHT
	DOWN LIGHT
	SWITCH
	PENDANT LIGHT
	CIRCUIT NUMBER
	POWER PANEL

1 ARCHITECTURE AND ENGINEERING BUILDING
GROUND FLOOR LIGHTING PLAN
 E-2 SCALE 1:100 M

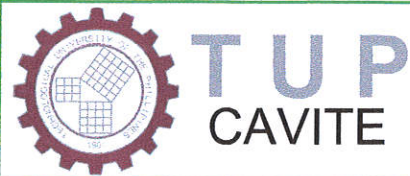

OWNER
 TECHNOLOGICAL UNIVERSITY OF THE PHILIPPINES
 CAVITE CAMPUS

PROFESSIONAL ELECTRICAL ENGINEER
 REG NO: DATE ISSUED:
 DATE EXPIRED: PLACE ISSUED:
 PTR NO: TIN NO:

DRAWN BY:
 REV NO.: DATE:

PROJECT TITLE
 PROPOSED ENGINEERING AND ARCHITECTURE BUILDING
 LOCATION: CQT, AVE, BRGY. SALAWAG, DASMARIÑAS CITY, CAVITE, PHILIPPINES

SHEET CONTENT

SHEET NO.

E
 2

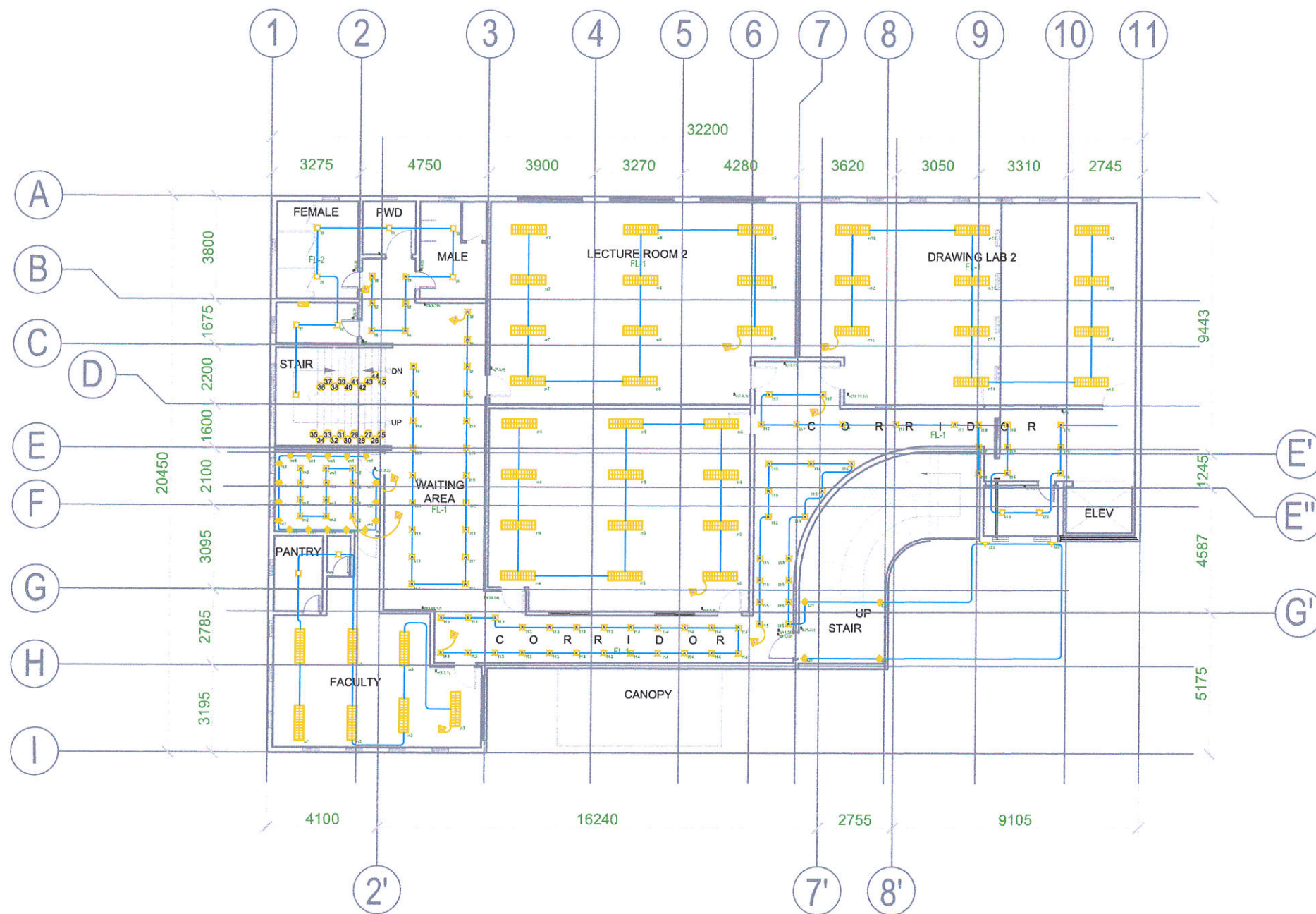

ELECTRICAL LEGEND	
	FLAT PANEL LIGHT
	CEILING LIGHT
	LOUVER
	PIN LIGHT
	CHANDELIER
	RECESSED LIGHT
	SPOT LIGHT
	WALL SCONCE
	COVE LIGHT
	DOWN LIGHT
	SWITCH
	PENDANT LIGHT
	CIRCUIT NUMBER
	POWER PANEL

1 ARCHITECTURE AND ENGINEERING BUILDING
GROUND FLOOR LIGHTING PLAN
 E-2 SCALE 1:100 M



OWNER
 TECHNOLOGICAL UNIVERSITY OF THE PHILIPPINES
 CAVITE CAMPUS

PROFESSIONAL ELECTRICAL ENGINEER
 REG NO: DATE ISSUED:
 DATE EXPIRED: PLACE ISSUED:
 PTR NO: TIN NO:

DRAWN BY:
 REV NO.: DATE:

PROJECT TITLE
 PROPOSED ENGINEERING AND ARCHITECTURE BUILDING
 LOCATION: CQT. AVE. BRGY. SALAWAG, DASMARIÑAS CITY, CAVITE, PHILIPPINES

SHEET CONTENT

SHEET NO.

E
 3

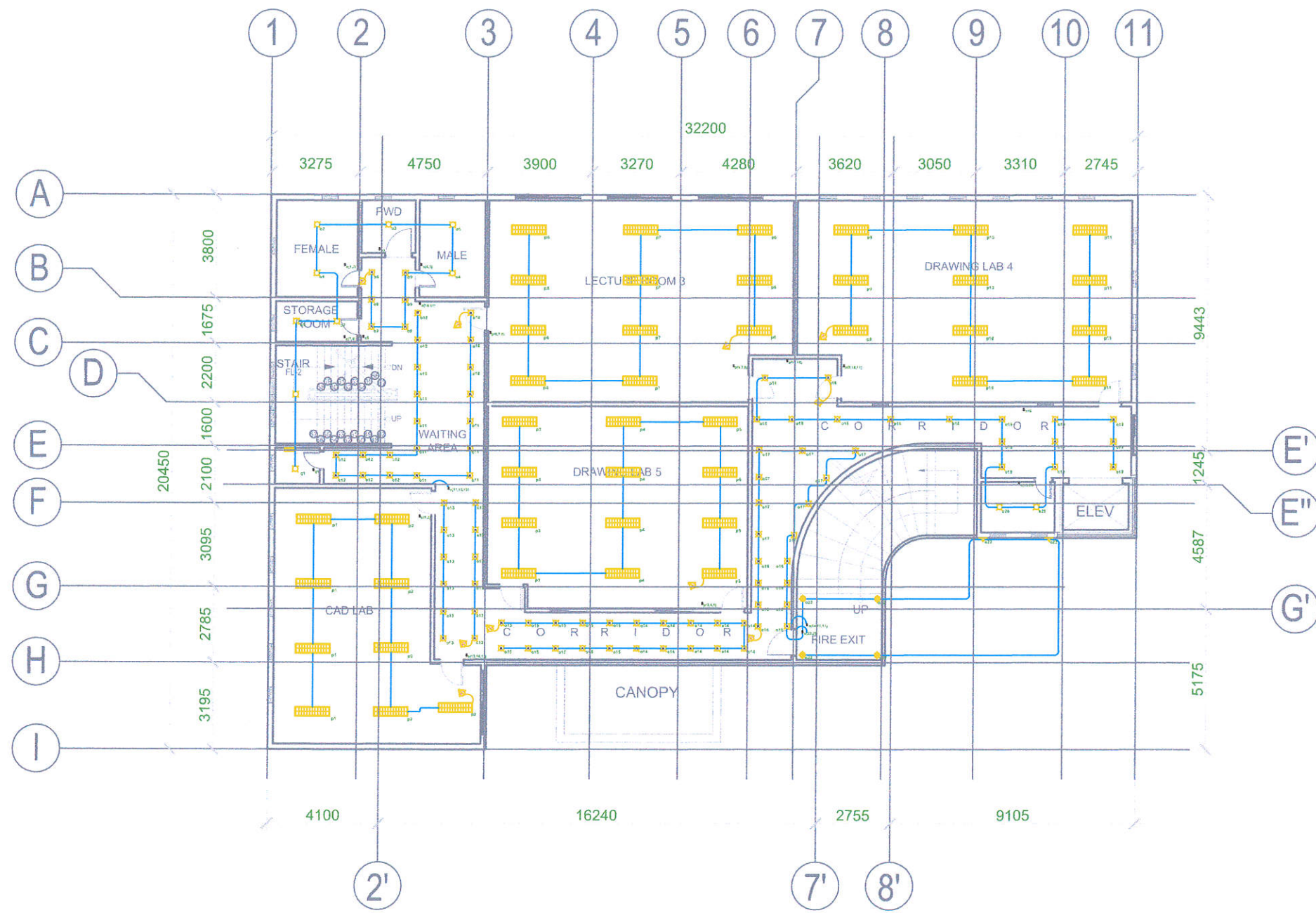

ELECTRICAL LEGEND	
	FLAT PANEL LIGHT
	CEILING LIGHT
	LOUVER
	PIN LIGHT
	CHANDELIER
	RECESSED LIGHT
	SPOT LIGHT
	WALL SCONCE
	COVE LIGHT
	DOWN LIGHT
	SWITCH
	PENDANT LIGHT
	CIRCUIT NUMBER
	POWER PANEL

1 ARCHITECTURE AND ENGINEERING BUILDING
GROUND FLOOR LIGHTING PLAN
 E-2 SCALE 1:100 M

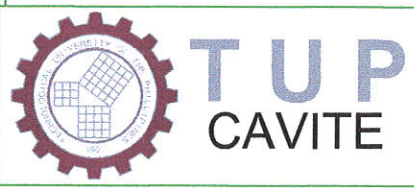

OWNER
 TECHNOLOGICAL UNIVERSITY OF THE PHILIPPINES
 CAVITE CAMPUS

PROFESSIONAL ELECTRICAL ENGINEER
 REG NO: _____ DATE ISSUED: _____
 DATE EXPIRED: _____ PLACE ISSUED: _____
 PTR NO: _____ TIN NO: _____

DRAWN BY: _____
 REV NO.: _____ DATE: _____

PROJECT TITLE
 PROPOSED ENGINEERING AND ARCHITECTURE BUILDING
 LOCATION: CQT. AVE. BRGY. SALAWAG, DASMARIÑAS CITY, CAVITE, PHILIPPINES

SHEET CONTENT

SHEET NO.
E
4

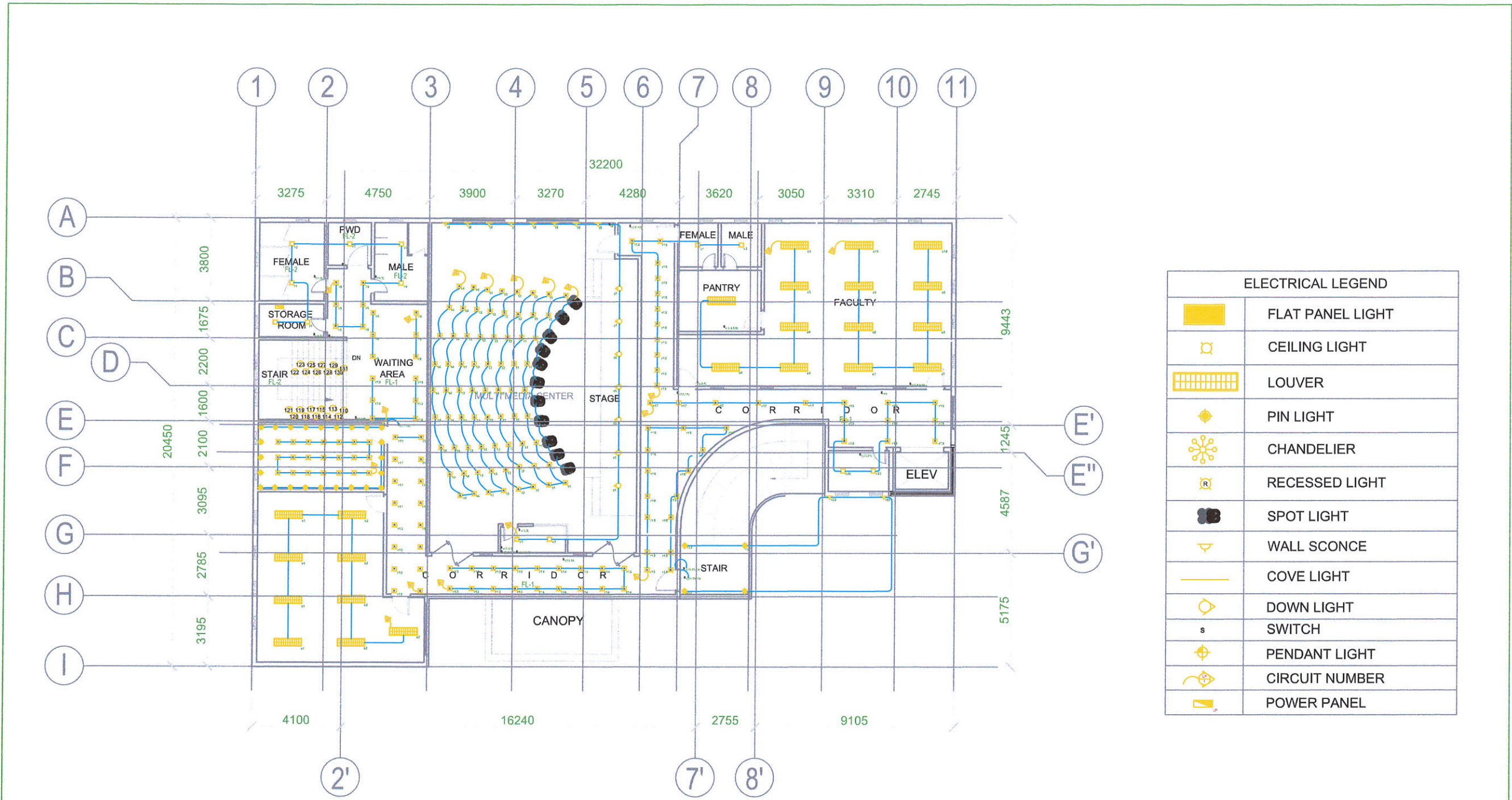

1 ARCHITECTURE AND ENGINEERING BUILDING
GROUND FLOOR LIGHTING PLAN
 E-2 SCALE 1:100 M

	OWNER	TECHNOLOGICAL UNIVERSITY OF THE PHILIPPINES CAVITE CAMPUS	PROFESSIONAL ELECTRICAL ENGINEER	DRAWN BY:	PROJECT TITLE	SHEET CONTENT	SHEET NO.
	REG NO:	DATE ISSUED:	REV NO.:	DATE:	PROPOSED ENGINEERING AND ARCHITECTURE BUILDING	E	5
	DATE EXPIRED:	PLACE ISSUED:	TIN NO:	LOCATION: CQT. AVE. BRGY. SALAWAG, DASMARIÑAS CITY, CAVITE, PHILIPPINES			

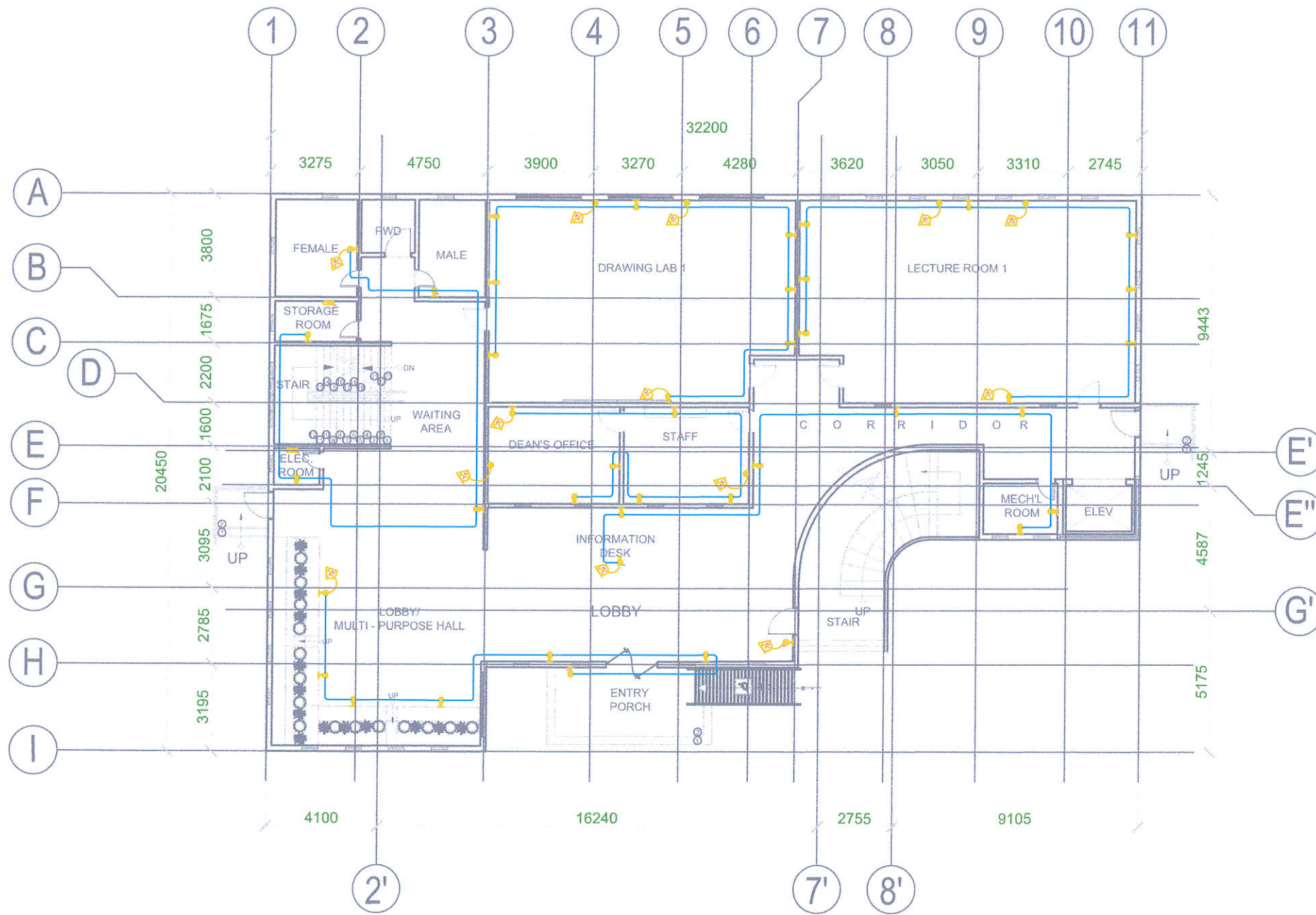

ELECTRICAL SYMBOL	
	THREE - GANG OUTLET
	TWO - GANG OUTLET
	WATER PROOF OUTLET
	FLOOR MOUNTED OUTLET
	EMERGENCY OUTLET
	CIRCUIT NUMBER
	POWER PANEL
	AIR CONDITIONING OUTLET

1 ARCHITECTURE AND ENGINEERING BUILDING
GROUND FLOOR POWER PLAN
 E-6 SCALE 1:100 M



OWNER
TECHNOLOGICAL UNIVERSITY OF THE PHILIPPINES
 CAVITE CAMPUS

PROFESSIONAL ELECTRICAL ENGINEER
 REG NO: _____ DATE ISSUED: _____
 DATE EXPIRED: _____ PLACE ISSUED: _____
 PTR NO: _____ TIN NO: _____

DRAWN BY: _____
 REV NO.: _____ DATE: _____

PROJECT TITLE
PROPOSED ENGINEERING AND ARCHITECTURE BUILDING
 LOCATION: CQT. AVE. BRGY. SALAWAG, DASMARIÑAS CITY, CAVITE, PHILIPPINES

SHEET CONTENT

SHEET NO.
E
6

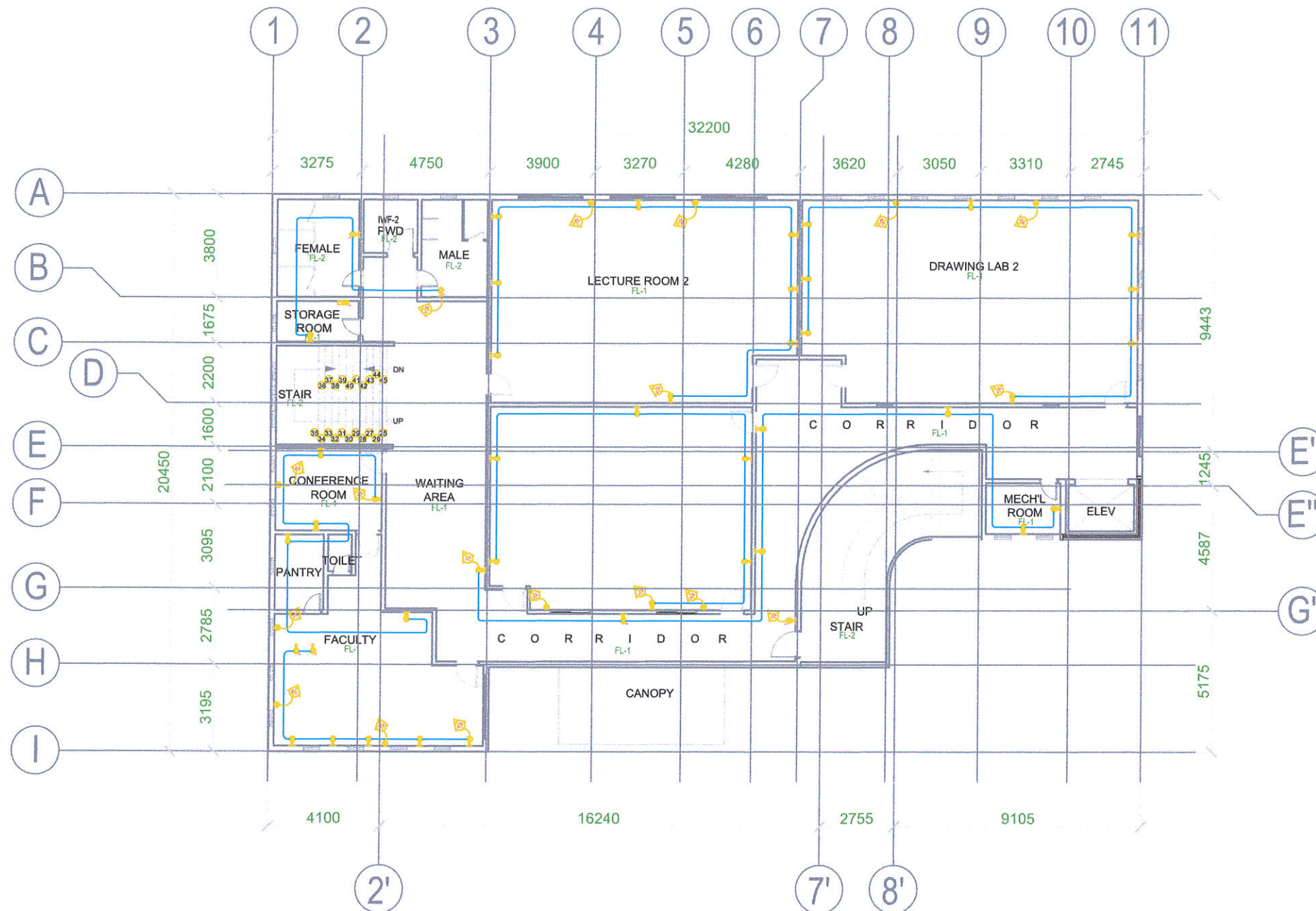

ELECTRICAL SYMBOL	
	THREE - GANG OUTLET
	TWO - GANG OUTLET
	WATER PROOF OUTLET
	FLOOR MOUNTED OUTLET
	EMERGENCY OUTLET
	CIRCUIT NUMBER
	POWER PANEL
	AIR CONDITIONING OUTLET

1 ARCHITECTURE AND ENGINEERING BUILDING
 E-7 SECOND FLOOR POWER PLAN
 SCALE 1:100 M



OWNER
 TECHNOLOGICAL UNIVERSITY OF THE PHILIPPINES
 CAVITE CAMPUS

PROFESSIONAL ELECTRICAL ENGINEER
 REG NO: DATE ISSUED:
 DATE EXPIRED: PLACE ISSUED:
 PTR NO: TIN NO:

DRAWN BY:
 REV NO.: DATE:

PROJECT TITLE
 PROPOSED ENGINEERING AND ARCHITECTURE BUILDING
 LOCATION: CQT. AVE. BRGY. SALAWAG, DASMARIÑAS CITY, CAVITE, PHILIPPINES

SHEET CONTENT

SHEET NO.
 E
 7

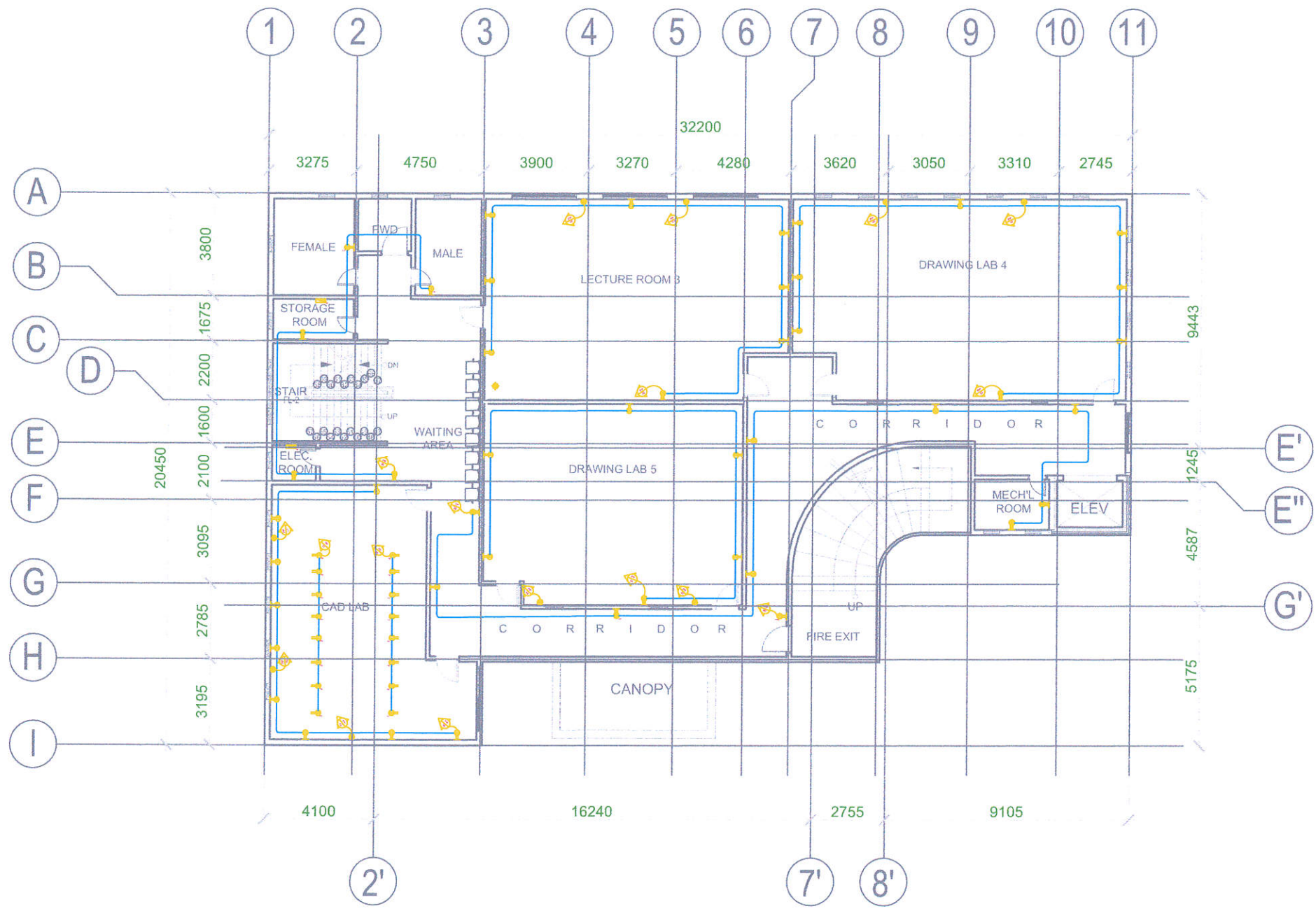

ELECTRICAL SYMBOL	
	THREE - GANG OUTLET
	TWO - GANG OUTLET
	WATER PROOF OUTLET
	FLOOR MOUNTED OUTLET
	EMERGENCY OUTLET
	CIRCUIT NUMBER
	POWER PANEL
	AIR CONDITIONING OUTLET

1 ARCHITECTURE AND ENGINEERING BUILDING
TYPICAL 3RD TO 5TH FLOOR POWER PLAN
 E-8 SCALE 1:100 M

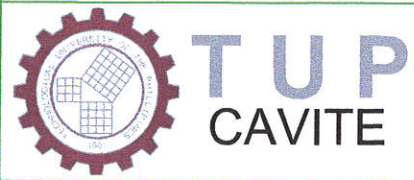

OWNER
 TECHNOLOGICAL UNIVERSITY OF THE PHILIPPINES
 CAVITE CAMPUS

PROFESSIONAL ELECTRICAL ENGINEER
 REG NO: _____ DATE ISSUED: _____
 DATE EXPIRED: _____ PLACE ISSUED: _____
 PTR NO: _____ TIN NO: _____

DRAWN BY: _____
 REV NO.: _____ DATE: _____

PROJECT TITLE
 PROPOSED ENGINEERING AND ARCHITECTURE BUILDING
 LOCATION: CQT. AVE. BRGY. SALAWAG, DASMARIÑAS CITY, CAVITE, PHILIPPINES

SHEET CONTENT

SHEET NO.
E
8

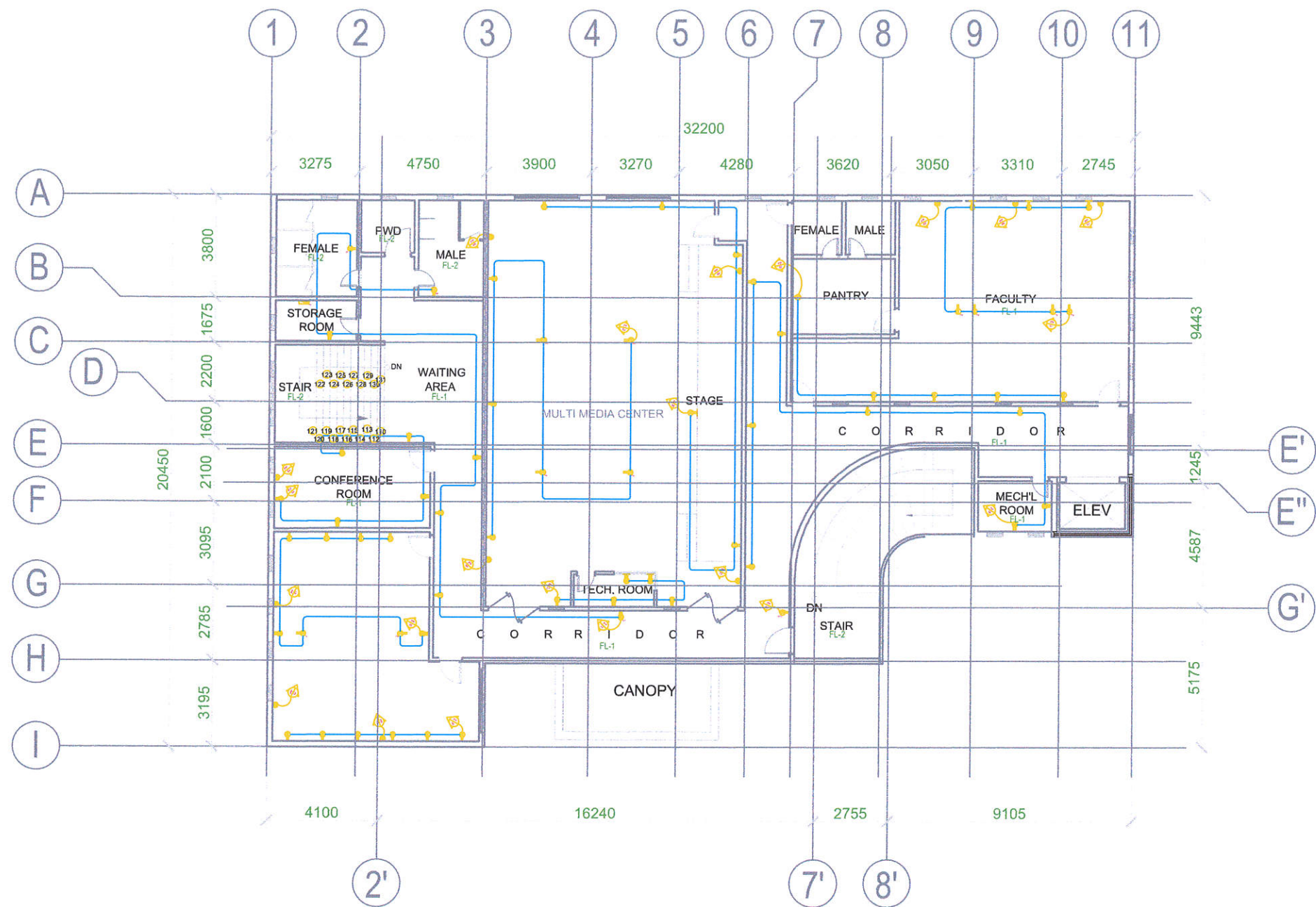

ELECTRICAL SYMBOL	
	THREE - GANG OUTLET
	TWO - GANG OUTLET
	WATER PROOF OUTLET
	FLOOR MOUNTED OUTLET
	EMERGENCY OUTLET
	CIRCUIT NUMBER
	POWER PANEL
	AIR CONDITIONING OUTLET

1 ARCHITECTURE AND ENGINEERING BUILDING
6TH FLOOR POWER PLAN
 E-9 SCALE 1:100 M

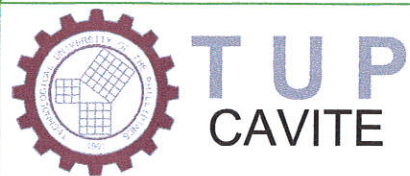

OWNER
 TECHNOLOGICAL UNIVERSITY OF THE PHILIPPINES
 CAVITE CAMPUS

PROFESSIONAL ELECTRICAL ENGINEER
 REG NO: DATE ISSUED:
 DATE EXPIRED: PLACE ISSUED:
 PTR NO: TIN NO:

DRAWN BY:
 REV NO.: DATE:

PROJECT TITLE
 PROPOSED ENGINEERING AND ARCHITECTURE BUILDING
 LOCATION: CQT, AVE, BRGY. SALAWAG, DASMARIÑAS CITY, CAVITE, PHILIPPINES

SHEET CONTENT

SHEET NO.

E
 9



PROGRAM OF WORK OF ARCHITECTURE AND ENGINEERING BUILDING AT TUP CAVITE (PHASE I)



**TECHNOLOGICAL UNIVERSITY OF THE PHILIPPINES
CAVITE CAMPUS**

Carlos Q. Trinidad Ave., Salawag, Dasmariñas City, Cavite

**PROGRAM OF WORK FOR THE PROPOSED
TUPC ENGINEERING AND ARCHITECTURE BUILDING**

SCOPE OF WORKS

A. SITE WORK

	QTY	UNIT	UNIT PRICE	
I. GENERAL	1	lot	55000.00 /lot	P
1. Mobilization and Demobilization				
2. Contractor Temporary Facility				
			MATERIAL COST	P
			LABOR COST	P
			DIRECT COST	P
II. PHASE 200 - CIVIL	1	lot	110000.00 /lot	P
1. Site Preparation/ Soil Boring Test				
2. Grade and Compaction of the access road				
3. Slope protection (Riprap)				
4. Established final grading				
5. Establish facilities final coordinates				
6. Facility Excavation Works				
7. Sheeting and Shoring				
8. Dewatering procedure (if required)				
			MATERIAL COST	P
			LABOR COST	P
			DIRECT COST	P
III. PHASE 500-MECHANICAL/FIRE PROTECTION/PIPING	1	lot	33000.00 /lot	P
1. Site Sanitary Gravity Sewer System				
2. Site Drinking Water System Network				
3. Site Raw Water System Network				
4. Site Fire Water System Network				
			MATERIAL COST	P
			LABOR COST	P
			DIRECT COST	P

B. FACILITIES WORK

I. GENERAL	1	lot	110000.00 /lot	P
1. All Necessary Permits				
2. Submit Complete Shop Drawing (as required)				
3. SAFETY Provisions				
			MATERIAL COST	P
			LABOR COST	
			DIRECT COST	P
II. PHASE 200 - ARCHITECTURAL	1	lot	17250000.00 /lot	P
1. WOOD AND PLASTICS				
2. DOORS AND WINDOWS				
3. FINISHES				
4. SPECIALTIES				
			MATERIAL COST	P
			LABOR COST	
			DIRECT COST	P

	QTY UNIT	UNIT PRICE	
III. PHASE 200 - STRUCTURAL	1 lot	42000000.00 /lot	P
1. Reinforced Concrete Foundations & Cast In-Situ Retaining Walls (Ready mix)			
2. Wall Foundations			
3. Reinforced Concrete Slab On-Grade			
4. Reinforced Concrete Columns, Beams and Suspended Slabs (Ready mix)			
5. Reinforced Concrete Stairs/Steps			
6. Concrete Up Stand and parapet wall			
7. Steel Works			
		MATERIAL COST	P
		LABOR COST	
		DIRECT COST	P
 IV. PHASE 500 – MECHANICAL / HVAC / PLUMBING / FIRE PROTECTION / EQUIPMENT	 1 lot	 13200000.00 /lot	 P
1. HVAC			
2. Plumbing			
3. Fire Protection (FDAS)			
4. Equipment			
5. Elevator			
6. Testing and Commissioning			
		MATERIAL COST	P
		LABOR COST	
		DIRECT COST	P
 V. PHASE 700 - ELECTRICAL	 1 lot	 13200000 /lot	 P
1. Switchboards - Panel boards and breakers			
2. Wiring Devices			
3. Lighting fixtures and switches			
4. Grounding System			
5. Fire Detection and Alarm System			
6. Transformer and Generator Set			
7. Testing and Commissioning			
		MATERIAL COST	P
		LABOR COST	P
		DIRECT COST	P
 VI. PHASE 780 - TELECOMMUNICATIONS & SURVELANCE	 1 lot	 330000 /lot	 P
1. Telephone line, Internet access (WIFI)			
2. CCTV's, Data and Voice Ports			
		MATERIAL COST	P
		LABOR COST	P
		DIRECT COST	P
 V. PHASE 700 - INSTRUMENTATION	 1 lot	 3300000 /lot	 P
1. Pump Instrumentation			
2. Controls and Instrumentation for Diesel Engine driven Firewater pumps			
3. Main Control Panel in the Electrical Room			
4. indoor Automatic Transfer Switch			
		MATERIAL COST	P
		LABOR COST	P
		DIRECT COST	P

A TOTAL DIRECT COST **P**
B OVERHEAD/CONTIGENCY/MISC
C CONTRACTOR'S PROFIT
EVAT (12%) $12\%*(A+B+C)$
TOTAL ESTIMATED PROJECT COST P

Prepared by:

Engr. Carlito R. Sapida
IDO-Chairperson

Approved by:

Myrna M. Tepora, Ph.D.
Campus Director



DETAILED SCOPE OF WORKS OF ARCHITECTURE AND ENGINEERING BUILDING AT TUP CAVITE (PHASE I)



**TECHNOLOGICAL UNIVERSITY OF THE PHILIPPINES
CAVITE CAMPUS**

Carlos Q. Trinidad Avenue, Salawag, Dasmariñas City, Cavite, Philippines
Telefax: (046) 416-4920
Email: cavite@tup.edu.ph | Website: www.tup.edu.ph



Management System
ISO 9001:2015
www.tuv.com
ID 9108652185



1. INTRODUCTION

This Construction Scope of Work together with the drawings, applicable Engineering Standards and Industry Standards listed in this document, constitute the technical basis for the complete work to be performed by the CONTRACTOR for the Construction of the TUPC Engineering and Architectural Building, Salawag Dasmariñas City. It describes only the technical aspects of the activities required for this project and must be read in conjunction with other Contract Schedules to obtain a complete understanding of the requirements of the contract.

2. PROJECT SUMMARY

Construction of the TUPC Engineering and Architectural Building, Salawag, Dasmariñas City, Cavite

3. APPLICABLE CODE AND STANDARDS

3.1. GENERAL CODES AND STANDARDS

RA6541 National Building Code of the Philippines	2018
RA1378 Revised Plumbing Code of the Philippines	1999
RA9514-Fire Code of the Philippines	2019
RA 7920 - Philippine Electrical Code	2019

3.2. INDUSTRIAL CODES AND STANDARDS

3.3. LOCAL GOVERNMENT LAWS AND ORDINANCES

3.4. MATERIAL SPECIFICATIONS STANDARD

3.5. STANDARD AND LIBRARY DRAWINGS

4. DETAILED DESCRIPTION OF SITE WORK

4.1. GENERAL

4.1.1. This includes Mobilization of equipment, materials, formworks, manpower and other related items needed to construct the facility.

4.1.2. The contractor shall prepare their temporary facility, material warehouse and specimen storage area for testing.

4.2. PHASE 200 – CIVIL

The CONTRACTOR shall provide all civil site works required for TUPC Engineering and Architectural Building as detailed herein:

4.2.1. Site preparation which includes site development/layout and final site grading for the whole area as shown on the drawings. The CONTRACTOR shall establish the grade levels to meet the desired grading requirements for the buildings and



**TECHNOLOGICAL UNIVERSITY OF THE PHILIPPINES
CAVITE CAMPUS**

Carlos Q. Trinidad Avenue, Salawag, Dasmariñas City, Cavite, Philippines
Telefax: (046) 416-4920
Email: cavite@tup.edu.ph | Website: www.tup.edu.ph



Management
System
ISO 9001:2015
www.tuv.com
ID 9108652185



storm water surface run-off. Backfilling and compaction shall comply with SAES-A-114.

- 4.2.2. CONTRACTOR shall grade, compact and construct the access road and necessary paved and unpaved shoulders shall also be the responsibility of the Contractor along with the required sidewalks upon securing and ensuring proper accessibility all around the Engineering and Architectural Building area. Asphalt shoulders and marl shoulders shall be provided wherever applicable as shown and detailed in the design drawings (xxxxx).
- 4.2.3. CONTRACTOR shall have slope protection such as RIPRAP for areas as shown and detailed in the design drawings (xxxxx).
- 4.2.4. The CONTRACTOR shall establish the grade levels to meet the desired grading requirements for the buildings and storm water drainage (surface run off). Backfilling and compaction shall comply with SAES-A-114. Grading cuts shall also be performed, as required, meeting the requirements as detailed and shown on the designed Grading and Drainage Plan Drawings (xxxx).
- 4.2.5. Prior to construction, CONTRACTOR shall verify the accuracy of the coordinates provided at specific corners of the buildings, boundary fences, roads and at all other essential points as shown on the drawings (xxxxx).
- 4.2.6. Excavate and construct building support foundations according to the lines and grades shown in the drawings.
- 4.2.7. CONTRACTOR shall provide sheeting or shoring in accordance with applicable Construction Safety Manual.
- 4.2.8. CONTRACTOR shall commence dewatering procedures whenever necessary in areas where deep excavation is required. No construction shall start until the design of the de-watering system has been approved by TUPC PMC Representative.

4.3. PHASE 500 – MECHANICAL PLUMBING / FIRE PROTECTION / PIPING

The CONTRACTOR shall provide all mechanical site works required for TUPC Engineering and Architectural Building as detailed herein:

- 4.3.1. Excavate to required depth & alignment and provide sanitary gravity sewer system including but not limited to: PVC pipes and fittings for sewer network. All sewer facilities listed in the previous section shall be connected to the existing sewer network system. The sub-main system collecting discharge from the individual buildings shall tie-in to the main network as shown and detailed on the design drawings. The Sanitary Sewer System shall be in accordance with RA1378 National Plumbing Code of the Philippines.
- 4.3.2. Excavate to required depth & alignment and provide drinking water system network to all drinking water fountain and buildings requiring such system including but not limited to: pipes, fittings, valves, booster pumps and service valve boxes as shown on the design drawings (xxxxx). The drinking water lines serving the individual facilities shall tie-in to the existing water line. Drinking/Potable water system shall be in accordance with applicable codes and standards. Installation of the drinking water system shall comply with the requirement stipulated in applicable codes and standards and pressure testing shall be in accordance with RA1378 National Plumbing Code of the Philippines.
- 4.3.3. Excavate to required depth & alignment and provide Raw Water system network including (but not limited to) pipes, fittings, valves, booster pumps and service valve boxes as shown on the design drawings (xxxxx). The raw water lines serving



**TECHNOLOGICAL UNIVERSITY OF THE PHILIPPINES
CAVITE CAMPUS**

Carlos Q. Trinidad Avenue, Salawag, Dasmariñas City, Cavite, Philippines
Telefax: (046) 416-4920
Email: cavite@tup.edu.ph | Website: www.tup.edu.ph



Management
System
ISO 9001:2015

www.tuv.com
ID 9108652185



a particular facility shall tie-in from the existing domestic water line as shown and detailed in the design drawings.

- 4.3.4. Excavate to required depth & alignment and provide fire water system network including, but not limited to, RTR pipes, fittings, direct buried valves, post indicator valves, hydrants, and fire water pumping station as shown on the design drawings (VA-716526). Cathodic protection shall also be provided for all fire device metallic pipe risers. Fire water system network shall be supplied and pumped by new set of fire pumps where water is being drawn from the new fire water tanks provided for this project. A stub-out connection shall be provided in the area of the network for future connection during expansion.

4.4. PHASE 700 – ELECTRICAL

The CONTRACTOR shall provide all electrical site works required for TUPC Engineering and Architectural Building as detailed herein:

- 4.4.1. Provide labor, materials, tools, machinery, equipment, appliances, fixtures, devices, and services necessary to complete the specified electrical work of TUPC Engineering and Architectural Building with other trades to prevent conflicts without impeding job progress.

- 4.4.2. The Contractor shall pay fees, service charges, tap charges, meter charges, and special fees assessed by the local utilities or local authorities.

- 4.4.3. A complete power distribution system including, but not limited to:

- a. Service entrance/provisions.
- b. Switchboards/Switchgear/Unit Substations [modifications].
- c. Cable feeders and raceways.
- d. Busway.
- e. Automatic Transfer Switches.
- f. Motor Control Centers/Enclosed Motor Controllers.
- g. Emergency Generator paralleling switchgear.
- h. Panelboards.
- i. Transformers.
- j. Packaged Electric Generating System.
- k. Transient voltage surge protection devices.
- l. Lightning Protection System.
- m. Grounding System
- n. Lighting Fixtures, Lamps and Ballast

- 4.4.4. A complete emergency power system including, but not limited to:

- a. Battery Emergency Power Supply
- b. Generator paralleling gear
- c. Automatic transfer switches and controls.
- d. Cable feeders and raceways.
- e. Distribution panels.
- f. Panelboards.
- g. Transformers.
- h. Enclosed circuit breakers, switches, and fuses.
- i. All other components shown on the Drawings, specified or required for a fully operational emergency power systems.

- 4.4.5. A complete lighting system including, but not limited to:

- a. Lighting fixtures and lamps.
- b. Exit and egress lighting fixtures and lamps.



**TECHNOLOGICAL UNIVERSITY OF THE PHILIPPINES
CAVITE CAMPUS**

Carlos Q. Trinidad Avenue, Salawag, Dasmariñas City, Cavite, Philippines

Telefax: (046) 416-4920

Email: cavite@tup.edu.ph | Website: www.tup.edu.ph



Management
System
ISO 9001:2015

www.tuv.com
ID 9108652185



- c. Switches, dimming and controls.
 - d. Branch circuit wiring and raceways.
 - e. All other components shown on the Drawings, specified, or required for a fully operational lighting system.
- 4.4.6. A complete branch circuit distribution system including, but not limited to:
- a. Branch circuit wiring and raceways.
 - b. Wiring devices.
 - c. Multi-outlet assemblies.
 - d. Safety and disconnect switches.
 - e. Relays, contactors, and controls.
 - f. Connections to motors and equipment.
 - g. All other components shown on the Drawings, specified, or required for a fully operational branch circuit distribution system.
- 4.4.7. A complete grounding system including, but not limited to:
- a. Ground Rods and Electrodes.
 - b. Bonding.
 - c. Ground conductors and raceways.
 - d. All other components shown on the Drawings, specified, or required for a fully operational grounding system.
- 4.4.8. A complete system of miscellaneous electric controls and control wiring as shown on the Drawings and specified.
- 4.4.9. CONTRACTOR shall provide supply, installation, testing and commissioning of 3 units Electric Transformers.
- 4.4.10. CONTRACTOR shall provide supply, installation, testing and commissioning of 1 unit Electric Generators w/ ATS.
- 4.4.11. CONTRACTOR shall provide Fire Detection and Alarm System (FDAS) Roughing Ins, Telephone Roughing Ins, Intercom Roughing Ins and CCTV Roughing Ins.
- 4.4.12. Complete testing to all electrical systems.

5. DETAILED DESCRIPTION OF FACILITIES WORK

5.1. GENERAL

This Construction Scope is for the Construction of 6-Storey TUPC Engineering and Architectural Building inside the Technological University of the Philippines -Cavite Campus, located at Brgy. Salawag, Dasmariñas City.

The described facilities indicated shall be constructed in the following phase items.

The contractor shall be responsible to secure and process all necessary permits before and during construction until the turnover of the project.

The contractor shall be responsible for the overall safety of the site, manpower, materials, equipment, and around the perimeter of the construction site.

The Construction Contractor shall submit shop drawings for approval of TUPC Representative.



Description		Area, m ²
Ground Floor	Lobby	
	Multi-Purpose Hall	
	Stairs (2)	
	Elevator	
	Electrical Room	
	Toilets (Male, Female and PWD)	
	Storage Room	
	Mechanical Room	
	Drawing Lab 1	
	Lecture Room 1	
	Dean's Office	
	Staff Room	
Second Floor	Faculty w/ T&B & Pantry	
	Conference Room	
	Stairs (2)	
	Elevator	
	Electrical Room	
	Toilets (Male, Female and PWD)	
	Storage Room	
	Mechanical Room	
	Drawing Rooms (2)	
Waiting Area		
Third Floor (Typical up to Fifth floor)	CAD Laboratory	
	Lecture Room (2)	
	Stairs (2)	
	Elevator	
	Electrical Room	



**TECHNOLOGICAL UNIVERSITY OF THE PHILIPPINES
CAVITE CAMPUS**

Carlos Q. Trinidad Avenue, Salawag, Dasmariñas City, Cavite, Philippines
 Telefax: (046) 416-4920
 Email: cavite@tup.edu.ph | Website: www.tup.edu.ph



Management System
ISO 9001:2015



www.tuv.com
ID 9108652185

	Toilets (Male, Female and PWD)	
	Storage Room	
	Mechanical Room	
	Drawing Laboratory	
	Waiting Area	
Sixth Floor	Lecture Room	
	Storage	
	Elevator	
	Multi-Media Center w/ Tech. Room	
	Toilets (Male, Female and PWD)	
	Conference Room	
	Mechanical Room	
	Faculty w/ Male and Female Toilet & Pantry	
	Waiting Area	

5.2. PHASE 200 – ARCHITECTURAL

The architectural design shall address all project requirements and shall be compliant to the National Building Code of the Philippines and all other relevant codes and standards.

5.2.1. Woods and Plastic

5.2.1.1. The contractor shall provide a Fiber Cement Ceiling Board Material for the Ceiling.

5.2.1.2. The door used in Toilets located in every room is PVC Flush door with louver.

5.2.1.3. The Contractor must provide Wood Plastic Compodite Material. (See Front Elevation Plan for Reference)

5.2.2. Doors and Windows

5.2.2.1. Main Entrance should be Glass Material or Approved equal swing type.

5.2.2.2. The contractor shall use Steel door in every Fire Exits.

5.2.2.3. The Contractor shall be used in Windows located in Bedrooms and Basement is an Aluminum frame Glass material sliding window.

5.2.2.4. Windows used in bedrooms and facades are a wood frame awning window.



- 5.2.2.5. Windows used in Toilets is an Aluminum frame glass material awning window.
- 5.2.2.6. The contractor shall provide Glass window at the elevator. (See Front Elevation Plan for Reference)
- 5.2.3. Finishes
 - 5.2.3.1. Exterior and Interior walls is a Plain cement concrete finish with Paint. (See Architectural plan for reference).
 - 5.2.3.2. The Contractor shall provide Tiles for the flooring of the whole building.
 - 5.2.3.3. The contractor shall use Tiles for the wall and Toilet flooring.
- 5.2.4. Specialties
 - 5.2.4.1. The Contractor shall provide a curtain wall located in entrance and in the balcony in fourth floor.
 - 5.2.4.2. The Contactor shall provide a Parapet wall design in the façade.
 - 5.2.4.3. The contractor shall provide a Wood Composite Plastic (WPC) colored: Dark Brown in the facade.
 - 5.2.4.4. Contractor shall provide a Glass Canopy on the balcony in fourth floor.
 - 5.2.4.5. The contractor shall use Wall cladding. (See Architectural Elevation Plan)
 - 5.2.4.6. The contractor shall supply Maroon Aluminum Composite Panels, Stainless Lettering (See letter size in Elevation).
 - 5.2.4.7. The Contractor must provide Stainless Lettering and Logo at the Front Elevation. (See Front Elevation Plan for Reference)
 - 5.2.4.8. The Contractor shall provide a Plant box Design in the facade.
 - 5.2.4.9. Provide Canopy in windows.
 - 5.2.4.10. The contractor shall provide a steel stair located in the fire exits of the building.

5.3. PHASE 200 – STRUCTURAL

5.3.1. Wall Foundations

- 5.3.1.1. Place form work, vapor barrier, reinforcing steel and ties as required forming foundation for CMU walls. Pour concrete, ready mix or site mix as required or directed by the TUPC Engineer. Apply bitumen concrete coating to all surfaces in contact with soil.

5.3.2. Reinforced Concrete Slab On-Grade

- 5.3.2.1. Place form work, vapor barrier, reinforcing steel and ties as required forming for reinforced concrete slabs on grade. Pour concrete, ready mix or site mix as required or directed by the TUPC Engineer. Apply bitumen concrete coating to all surfaces in contact with soil.
- 5.3.2.2. All v-notch type contraction joints shall be spaced no more than 3 meters apart horizontally and vertically. Expansion type joints shall be spaced no more than 10 m apart horizontally.



-
- 5.3.2.3. As soon as form work is removed, tie wire, form ties and any other embedded item shall be cut back 2.54 cm (1 inch) and holes neatly and smoothly patched. Honey combing and places with loose aggregate shall be thoroughly cleaned and patched only after the TUPC Project Engineer's approval.
- 5.3.2.4. All exterior slabs and outdoor areas subject to foot traffic only shall have a light broom finish. All interior floor slabs, unless otherwise noted, shall have a steel trowel finish only.
- 5.3.3. Reinforced Concrete Columns, Beams and Suspended Slabs
- 5.3.3.1. CONTRACTOR shall perform the WORK which shall include but not be limited to preparing and performing all applicable activities necessary during the construction of columns, beams and suspended slabs. Placing and removal of shoring, form work, vapor barrier, cut bend and fix reinforcing bars, spacers and ties (any size) as required to form columns, beams and slabs. Provide lean concrete where required or as directed by the SAUDI ARAMCO Project Engineer. The WORK shall be plumbed, true and accurate to dimensions. Pour concrete, ready mix or site mix as required or approved by the TUPC Project Engineer. Curing and protection shall start immediately after final finishing operation.
- 5.3.3.2. As soon as form work is removed, tie wire, form ties and any other embedded item shall be cut back 2.54 cm (1 inch) and holes neatly and smoothly patched. Honey combing and places with loose aggregate shall be thoroughly cleaned and patched only after the Saudi ARAMCO Project Engineer's approval.
- 5.3.4. Reinforced Concrete Foundations & Cast In-Situ Retaining Walls
- 5.3.4.1. CONTRACTOR shall perform the WORK which shall include but not be limited to preparing and performing all applicable activities necessary during the construction of general foundations and retaining/cast in-situ walls. Placing and removal of shoring, form work, vapor barrier, cut bend and fix reinforcing bars, spacers and ties (any size) as required to form foundations and retaining walls. Provide lean concrete where required or as directed by the TUPC Project Engineer. The WORK shall be plumbed, true and accurate to dimensions. Pour concrete, ready mix or site mix as required or approved by the TUPC Project Engineer. Provide weep holes at locations indicated on the project drawings along with appropriate backfill to maintain free drainage behind retaining walls. Apply bitumen concrete coating to all surfaces in contact with soil.
- 5.3.5. Reinforced Concrete Stairs/Steps
- 5.3.5.1. CONTRACTOR shall perform the WORK which shall include but not be limited to preparing and performing all applicable activities necessary during the construction of reinforced concrete stairs/steps. Construct reinforced CMU walls on reinforced concrete footings to support steps. Provide and install all necessary temporary formwork and reinforcing bars. Construct cast in-situ reinforced concrete steps on prepared backfill with polyethylene membrane.
- 5.3.5.2. Provide all joints including separation strips as required. Finish surfaces of steps smooth and provide chamfer to top edge of steps to the satisfaction of the TUPC Engineer or as specified on Scope of Work or drawings.



5.3.6. Concrete Up Stand

5.3.6.1. CONTRACTOR shall perform the WORK which shall include but not be limited to preparing and performing all applicable activities necessary during the construction of up stand over existing concrete slab. Placing and removal of form work, cut and fix (10mm or 12mm diameter) dowel bars (400 or 800 mm centers) and epoxy grouted to existing slab. The WORK shall be plumbed, true and accurate to dimensions. Pour concrete, ready mix or site mix as required or approved by the TUPC Project Engineer. Curing and protection shall start immediately after final finishing operation.

5.3.7. STRUCTURAL STEEL WORKS

5.3.7.1. Fire Exit Stairs

5.4. PHASE 500 – MECHANICAL / HVAC / PLUMBING / FIRE PROTECTION / EQUIPMENT

5.4.1. HVAC

- 5.4.1.1. Provide wall or roof mounted exhaust fans complete with prefabricated roof curb at the locations as shown on drawings.
- 5.4.1.2. Provide supply and return ceiling diffusers, supply & return grilles/registers, and exhaust disc valves/grilles.
- 5.4.1.3. Provide and install split type wall mounted fan coil units guest and faculty bedroom and the respective air- cooled condensers located on the roof deck will be interconnected with refrigerant piping.

5.4.2. PLUMBING

- 5.4.2.1. Provide and install cold water piping system.
- 5.4.2.2. Provide and install cold water supply by tapping-in to the external water network.
- 5.4.2.3. Provide and install various plumbing fixtures water closet, ablution hoses, lavatories, kitchen sink and janitor sink as shown on drawings.
- 5.4.2.4. Provide and install drinking water line for electric water coolers as required and shown on drawings.
- 5.4.2.5. Provide and install isolation valves on all branches of water distribution network.
- 5.4.2.6. Bidet hoses spray for water closets shall be provided with vacuum breakers to prevent backflow/back-siphonage.
- 5.4.2.7. All water closet and urinal flush-o-meter valves shall be equipped with vacuum breakers to prevent water backflow/back-siphonage.
- 5.4.2.8. Provide and install water hammer arrestors to suppress surge pressure in water supply system.
- 5.4.2.9. Provide and install sanitary waste, drain, and vent piping system including plumbing specialties.
- 5.4.2.10. Provide and install various plumbing fixtures.
- 5.4.2.11. A minimum of 2% slope for drainage lines shall be maintained in horizontal run inside the building.



**TECHNOLOGICAL UNIVERSITY OF THE PHILIPPINES
CAVITE CAMPUS**

Carlos Q. Trinidad Avenue, Salawag, Dasmariñas City, Cavite, Philippines
Telefax: (046) 416-4920

Email: cavite@tup.edu.ph | Website: www.tup.edu.ph



Management
System
ISO 9001:2015

www.tuv.com
ID 9108652195



- 5.4.2.12. The sanitary drainage system shall be properly vented and provided with cleanouts required maintaining a free flow.
- 5.4.2.13. Provide condensate drainpipes for A/C units and drop them into floor drains as shown on drawings.
- 5.4.2.14. Provide roof drains and down spouts for rainwater.

5.4.3. FIRE PROTECTION

The Mechanical-Fire Protection system shall include but not be limited to the following:

- 5.4.3.1. Provide and install Automatic Sprinkler System and Portable Fire Extinguishers including associated piping, supports and accessories in full Compliance with applicable clauses of NFPA 13R other applicable NFPA, RA9514-Fire Code of the Philippines and applicable industry standards.
- 5.4.3.2. Provide all related piping, valves and fittings and supports required to install, test, and commission the system.
- 5.4.3.3. Provide and install fire department connection and associated check valve for the sprinkler system.

5.4.4. EQUIPMENT

- 5.4.4.1. Elevator - Basement Mechanical Room
- 5.4.4.2. Diesel Generator - Basement Mechanical Room
- 5.4.4.3. Diesel Fire Pump – Basement Mechanical Room
- 5.4.4.4. Electric Fire pump - Basement Mechanical Room
- 5.4.4.5. Potable Water Booster Pump- Basement Mechanical Room
- 5.4.4.6. Fire Water Storage Tanks – Roof Deck
- 5.4.4.7. Potable Water Storage Tank – Roof Deck

5.5. PHASE 700 – ELECTRICAL

The CONTRACTOR shall provide all electrical site works required for TUPC Engineering and Architectural Building as detailed herein:

- 5.5.1. Provide and install Switchboards, building panel boards to electrical loads including the necessary accessories needed for the complete installation.
- 5.5.2. Provide and install wiring devices such as power receptacles, grounding and GFCI type as indicated on plan, including its cover plates, wirings, conduits, its appurtenances and all its accessories needed for the complete installation of power system.
- 5.5.3. Provide and install indoor and outdoor lighting fixtures, lamps, lighting switches, cover plates, lighting poles, lighting control panel & contactors, contactor switch, wirings, conduits, photocell its appurtenances and all its accessories needed for the complete installation of lighting system.
- 5.5.4. Provide and install an overall grounding system such as ground rods, ground test well ground cables, size and types as indicated in the plan, its appurtenances and all its accessories needed for the complete installation of the grounding system.



**TECHNOLOGICAL UNIVERSITY OF THE PHILIPPINES
CAVITE CAMPUS**

Carlos Q. Trinidad Avenue, Salawag, Dasmariñas City, Cavite, Philippines
Telefax: (046) 416-4920
Email: cavite@tup.edu.ph | Website: www.tup.edu.ph



Management
System
ISO 9001:2015

www.tuv.com
ID 9106652185



- 5.5.5. Provide and install LED light fixtures to save energy power in all facilities with minimum illumination levels as required by TUPC representative.
- 5.5.6. Provide and supply, installation, testing and commissioning of 1-unit Electric Transformers.
- 5.5.7. Provide and supply, installation, testing and commissioning of 1-unit Electric Generators w/ ATS.
- 5.5.8. Provide all roughing ins including Fire Detection and Alarm System (FDAS) Roughing Ins, Telephone Roughing Ins, Intercom Roughing Ins, and CCTV Roughing Ins.
- 5.5.9. Provide installation of Electric Meter Box, fabrication and installation of Meter Center including enclosure, busbar, and breaker gutter and any requirement for the energization.
- 5.5.10. Provide MERALCO and Power Company Energization Requirement Compliance and Processing.
- 5.5.11. Provide complete all testing of electrical system.
- 5.5.12. Fire Detection and Alarm System
 - 5.5.12.1. Supply, testing, pre-commissioning and provide necessary services during commissioning, and provide initial training for new equipment, and tools for programming Fire Detection and Alarm System (Addressable type) at various locations. This shall include modules, power supply, battery, smoke and heat detectors, FACP, Manual Pull Station, Horn – Strobe, etc.
 - 5.5.12.2. The project shall ensure that all New Fire Alarm System works shall be fully coordinated with the other discipline works.
 - 5.5.12.3. Telephone Dialers shall be provided to send the signals from Fire alarm Systems to main security guard station.
 - 5.5.12.4. Note: A Dedicated Telephone Line shall be provided for this purpose for the building mentioned above.
 - 5.5.12.5. Contractor shall perform Programming of Fire Alarm system.
 - 5.5.12.6. Provide Training on Operation, Maintenance and Programming of the Fire.
 - 5.5.12.7. Provide Programming Software, Programming devices, cables including software key to the Client.
 - 5.5.12.8. Provide Fire Alarm System Back-Up Program.
 - 5.5.12.9. Provide minimum spare parts as recommended by the Manufacturer.

5.6. PHASE 780 – TELECOMMUNICATION

5.7. PHASE 700 – INSTRUMENTATION

- 5.7.1. The CONTRACTOR shall supply and install the required pump instrumentation, controls, and protection for Firewater System Design.
- 5.7.2. The pump VENDOR shall supply and install the Controls and Instrumentation for Diesel Engine driven Firewater pumps.



**TECHNOLOGICAL UNIVERSITY OF THE PHILIPPINES
CAVITE CAMPUS**

Carlos Q. Trinidad Avenue, Salawag, Dasmariñas City, Cavite, Philippines
Telefax: (046) 416-4920
Email: cavite@tup.edu.ph | Website: www.tup.edu.ph



Management
System
ISO 9001:2015



www.tuv.com
ID: 9108652185

5.7.3. The CONTRACTOR shall supply and install the Main Control Panel in the Electrical Room.

5.7.4. Supply and install indoor Automatic Transfer Switch

6. APPLICABLE DOCUMENTS

6.1. DOCUMENT CONTROL

7. PROJECT CONTROL AND COORDINATION

8. GENERAL REQUIREMENTS

8.1. DRAWING VERIFICATION

8.2. DOCUMENTATION

8.3. ENGINEERING UNITS

8.4. AS-BUILT

8.5. WORK PERMIT

8.6. CONSTRUCTION SCHEDULE

9. MATERIALS

9.1. MATERIALS

9.2. MATERIAL PROCUREMENT PLAN

10. QUALITY CONTROL AND QUALITY ASSURANCE

11. CLEAN UP

12. TESTING AND COMMISSIONING

Prepared by:

Engr. Carlito R. Sapida

IDO-Chairperson

Approved by: ✓

Myrna M. Tepora, Ph.D.

Campus Director



RENOVATION OF GYMNASIUM AT TUP CAVITE CAMPUS



RDIP-NCR PROFILE FOR THE RENOVATION OF GYMNASIUM AT TUP CAVITE CAMPUS



REGIONAL DEVELOPMENT COUNCIL NATIONAL CAPITAL REGION (RDC-NCR)

“Where Metro Manila goes, so the country goes”

FORMULATION OF THE REGIONAL DEVELOPMENT INVESTMENT PROGRAM FOR THE NATIONAL CAPITAL REGION (RDIP-NCR) 2023-2028

IMPLEMENTING AGENCY: TECHNOLOGICAL UNIVERSITY OF THE PHILIPPINES CAVITE CAMPUS

CO-IMPLEMENTING AGENCY: NA

FOCAL PERSON: ATTY. DANILO M. ABAYON/OIC-Campus Director

CONTACT DETAILS: Carlos Q. Trinidad Avenue, Salawag, Dasmariñas City, Cavite/ (046) 416-4920

PROJECT PROFILE	
A. GENERAL INFORMATION	
TITLE	Renovation of Gymnasium at TUP Cavite Campus
PROGRAM¹ OR PROJECT²	<input type="checkbox"/> Program <i>Is it a regular program?³</i> <input type="checkbox"/> Yes ✓ <input type="checkbox"/> No <input checked="" type="checkbox"/> Project <i>Is this part/included in your Central Office's Public Investment Program (PIP)?</i> <input checked="" type="checkbox"/> Yes <input type="checkbox"/> No
STATUS	<input type="checkbox"/> Ongoing ⁴ <input checked="" type="checkbox"/> Proposed <input type="checkbox"/> Pipeline <input type="checkbox"/> Completed
DESCRIPTION	This is a project for the comprehensive renovation and upgrade of the existing campus gymnasium and related athletic/recreational facilities. The specific components include structural repairs, modernization of sporting equipment, improvement of safety features, and enhancement of ancillary facilities (e.g., locker rooms, seating areas) to meet modern standards. The facility's definite purpose is to provide a safe, functional, and enhanced venue for physical activity, health, and campus community engagement.
OBJECTIVES	The renovation addresses the critical development gap posed by the deterioration of recreational infrastructure, which limits the university's capacity to fully support the physical, mental, and social well-being of its population. An upgraded gymnasium revitalizes facilities essential for physical fitness and community engagement, serving as a vital component in improving the social determinants of student health. This project aligns with the PDP mandate to ensure that communities and schools support physical, mental, and social well-being for all, allowing Filipinos to enjoy longer and healthier lives and achieve fulfillment.

¹ A program is a group of activities and projects that contribute to a common particular outcome. A program should have the following: a) unique expected results or outcomes; b) clear target population or client group external to the agency; c) defined method of intervention to achieve the desired result; and d) a clear management structure that defines accountabilities.

² A project is a special undertaking carried out within a definite timeframe and intended to result in some pre-determined measure of goods and services.

³ Refers to a program being implemented on a regular basis. For regular programs, only the investment targets covering 2023-2028 shall be submitted.

⁴ Ongoing P/Ps are considered ongoing if they satisfy any of the following: (a) if locally funded - upon issuance of notice to proceed; (b) if Official Development Assistance (ODA)-assisted - upon effectivity of loan or grant agreement; and (c) if PPP or Joint Venture (JV)- upon signing of concession/JV agreement including unsolicited PPP P/Ps.

PROJECT PROFILE	
COMPONENTS	The project includes the following components: firstly, the construction of one covered court designed to accommodate various sports such as basketball, volleyball, and badminton. This multipurpose court will serve as a dynamic space for students and the campus community to engage in a range of athletic activities. Additionally, the project features the establishment of one adjacent room specifically designated for table tennis, providing a dedicated space for this popular recreational sport.
LOCATION/SCOPE	Carlos Q. Trinidad Avenue, Salawag, Dasmariñas City, Cavite
IMPLEMENTATION PERIOD	Start of implementation: 2 nd quarter of 2026 End of implementation: 1 st quarter of 2027
EXPECTED OUTPUTS	The outputs of the project encompass a modern covered court, enhanced recreational facilities, improved functionality and safety, aesthetic appeal, and overall support for holistic student development within the TUP Cavite Campus.
LEVEL OF GAD RESPONSIVENESS⁵	<input type="checkbox"/> GAD is invisible in the program/project <input type="checkbox"/> Program/Project has promising GAD prospects <input type="checkbox"/> Program/Project is gender-sensitive <input checked="" type="checkbox"/> Program/Project is gender-responsive
B. PROJECT FINANCING	
FINANCING SOURCE	<input checked="" type="checkbox"/> NG-Local <input type="checkbox"/> ODA Loan <input type="checkbox"/> ODA Grant <input type="checkbox"/> Internally-generated fund (for GOCCs/GFIs) <input type="checkbox"/> Private Sector <input type="checkbox"/> Others: Please specify, _____
YEAR	Amount (separate columns per funding source, if applicable)
	GAA/Internal Funds Other Funding Source/s
2023	- -
2024	- -
2025	- -
2026	- -
2027	30,000,000 -
2028	- -
Continuing Years	- -
Total (2023-2028)	30,000,000 -
TOTAL PROJECT COST	30,000,000 -
C. TYPOLOGY	
TYPE OF P/P	<input type="checkbox"/> Major Capital Investment Program and Project <input type="checkbox"/> Technical Assistance Program/Project (such as Research and Development, Institutional Development, Human Resource Capacity Building, or System/Process Improvement PAPs) <i>Is the Technical Assistance Program/Project considered a Research and Development Program/Project?</i> <input type="checkbox"/> Yes <input type="checkbox"/> No <input type="checkbox"/> Relending Program/Project of GFIs to LGUs and Target Beneficiary

⁵ Identify the Level of GAD Responsiveness of the program/project based on the score of the program/project using the appropriate Gender and Development (GAD) checklist (<https://neda.gov.ph/gender-and-development/>).

PROJECT PROFILE	
	<input checked="" type="checkbox"/> Government Facilities used as an office, housing, and other technical purposes
D. READINESS	
PROJECT PREPARATION DOCUMENT ACCOMPLISHED	<input type="checkbox"/> Feasibility Study F/S Cost (in exact PHP amount). _____ Status: <input type="checkbox"/> Completed <input type="checkbox"/> -Ongoing. Expected Completion Date: _____ <input type="checkbox"/> For Preparation. Start Date: _____ <input type="checkbox"/> Business Case <input type="checkbox"/> Project Proposal <input checked="" type="checkbox"/> Concept Note <input type="checkbox"/> Project Idea <input type="checkbox"/> Others: Detailed Engineering Design
APPROVALS	<input type="checkbox"/> RDC-NCR Approval <i>Date of Approval:</i> _____ <input type="checkbox"/> ICC/NEDA Board Approval not required Approval/s Secured: _____ Date of Approval: _____ Approval/s Required: _____ Target Date of Approval: _____ <input type="checkbox"/> ICC/NEDA Board Approval required <i>Status of ICC/NEDA Board Approval?</i> <input type="checkbox"/> Yet to be submitted to NEDA Secretariat Target Date of Submission: _____ <input type="checkbox"/> Under the NEDA Secretariat Review Date of Submission to NEDA Secretariat: _____ <input type="checkbox"/> ICC-TB Endorsed Date of Endorsement: _____ <input type="checkbox"/> ICC-CC Approved Date of Approval: _____ <input type="checkbox"/> NEDA Board Confirmed Date of Approval: _____
LEVEL OF READINESS	<input type="checkbox"/> Level 1: With the approval of appropriate authority ⁶ but not yet ongoing <input type="checkbox"/> Level 2: Project preparation document completed; For the approval of appropriate approving body in 2022 or 2023 and for inclusion in the NEP for FY 2023 <input checked="" type="checkbox"/> Level 3: Project preparation document currently being prepared and to be completed in 2023; for approval in 2024 and for inclusion in the NEP for FY 2025
FOR ONGOING P/Ps	
PHYSICAL ACCOMPLISHMENT	NA

⁶Please attach a copy of approval

PROJECT PROFILE

FINANCIAL ACCOMPLISHMENT

Year	Amount Included/for Inclusion in the NEP	Amount Allocated in the Budget/GAA	Actual Amount Disbursed
2023	-	-	-
2024	-	-	-
2025	-	-	-
2026	-	-	-
2027	30,000,000	-	-
2028	-	-	-

E. PROJECT/PROGRAM VIABILITY

Project benefits

This projects holds the potential for favorable outcomes. A well-executed renovation project with efficient resource allocation and enhanced athletic facilities may yield a positive economic internal rate of return, potentially ranging between 10% and 18%, showcasing the project's financial viability. Socially, the project's impact is significant. The renovated gymnasium, equipped with a covered court for various sports and a dedicated room for table tennis, is expected to enhance the overall well-being of students and the broader campus community. The modernized and inspiring space will facilitate a range of athletic and recreational activities, fostering physical health and community engagement. The qualitative impact on students' well-being, community spirit, and campus life could be substantial, showcasing the project's societal benefits. Moreover, the project aligns with the campus's commitment to sustainability by revitalizing existing facilities rather than constructing new ones. The potential for incorporating energy-efficient systems and sustainable materials in the renovation process may contribute positively to the environment, aligning with broader sustainability objectives."

Prepared by:



DARIUS L. FAJARDO
 Planning Officer
 March 02, 2026

Approved by:



ENGR. ALEXANDER E. MAG-ISA
 Campus Director
 March 02, 2026

(as of June 26, 2023)



DETAILED ENGINEERING DESIGN FOR THE RENOVATION OF GYMNASIUM AT TUP CAVITE CAMPUS



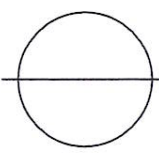

 TUPC GYMNASIUM
EXTERIOR PERSPECTIVE
 NOT TO SCALE

 TUP CAVITE	PROJECT TITLE:	PROPOSED BY:	APPROVED BY:	DESIGNED BY:	SHEET NO.
	PROPOSED TUPC GYMNASIUM	ENGR. BRYLLE EPHRAÏM Q. NAVARRO IDO, CHAIRPERSON	ENGR. ALEXANDER E. MAG-ISA, Ph.D.,PME CAMPUS DIRECTOR	IDO - CAVITE CAD BY:	<div style="border: 1px solid black; padding: 5px; display: inline-block;"> 1 A </div>





 TUPC GYMNASIUM
INTERIOR PERSPECTIVE 01
 NOT TO SCALE

 TUP CAVITE	PROJECT TITLE:	PROPOSED BY:	APPROVED BY:	DESIGNED BY:	SHEET NO.
	PROPOSED TUPC GYMNASIUM	ENGR. BRYLLE EPHRAIEM Q. NAVARRO IDO, CHAIRPERSON	ENGR. ALEXANDER E. MAG-ISA, Ph.D.,PME CAMPUS DIRECTOR	IDO - CAVITE CAD BY:	2 A



TUPC GYMNASIUM
 INTERIOR PERSPECTIVE 02
 NOT TO SCALE

 TUP CAVITE	PROJECT TITLE:	PROPOSED BY:	APPROVED BY:	DESIGNED BY:	SHEET NO.
	PROPOSED TUPC GYMNASIUM	ENGR. BRYLLE EPHRAIEM Q. NAVARRO IDO, CHAIRPERSON	ENGR. ALEXANDER E. MAG-ISA, Ph.D.,PME CAMPUS DIRECTOR	IDO - CAVITE CAD BY:	<div style="border: 1px solid black; padding: 5px; display: inline-block;"> 3 A </div>



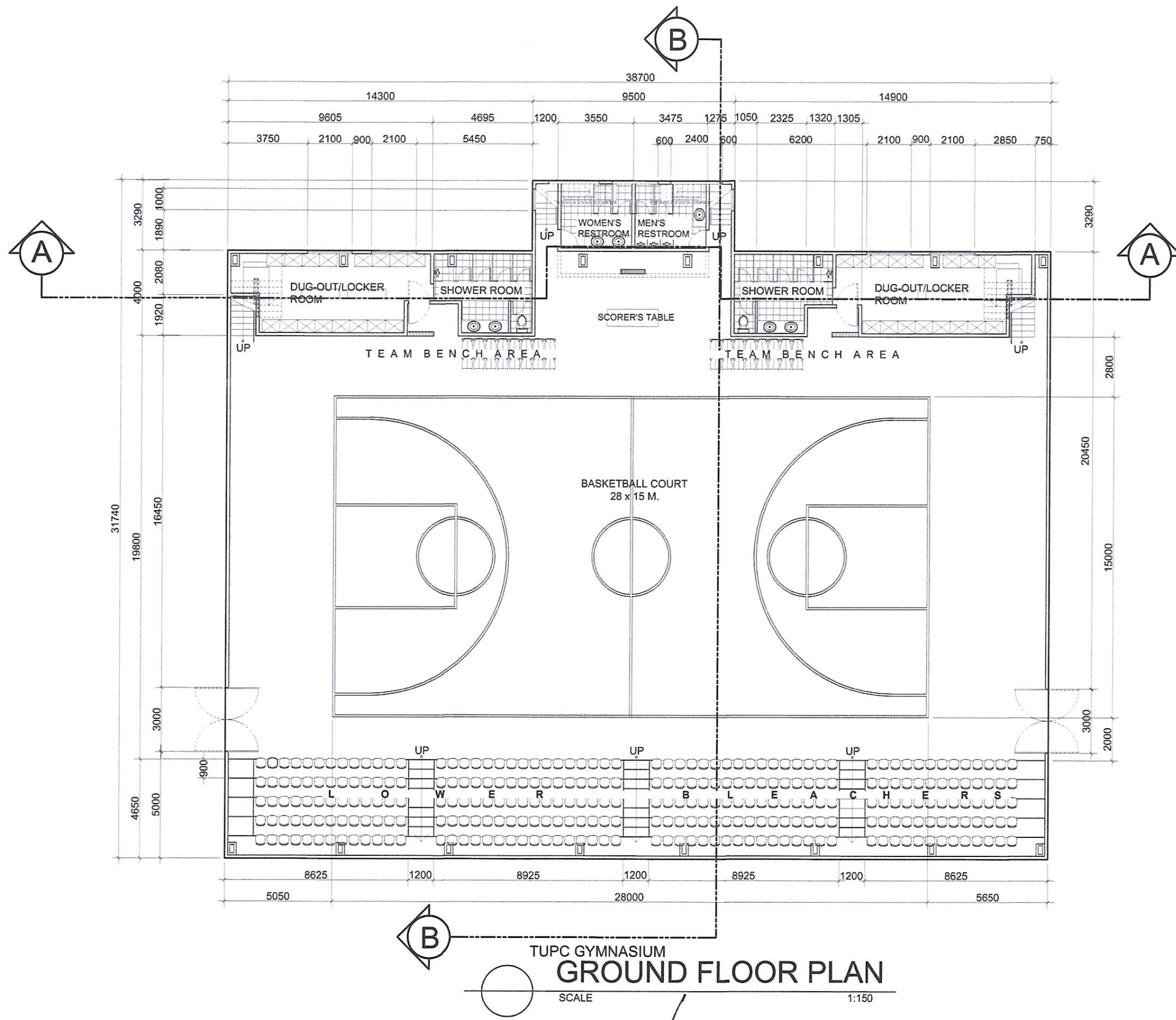

 TUPC GYMNASIUM
INTERIOR PERSPECTIVE 03
 NOT TO SCALE

 TUP CAVITE	PROJECT TITLE:	PROPOSED BY:	APPROVED BY:	DESIGNED BY:	SHEET NO.
	PROPOSED TUPC GYMNASIUM	ENGR. BRYLLE EPHRAIEM Q. NAVARRO IDO, CHAIRPERSON	ENGR. ALEXANDER E. MAG-ISA, Ph.D.,PME CAMPUS DIRECTOR	IDO - CAVITE CAD BY:	<div style="border: 1px solid black; padding: 5px; display: inline-block;"> 4 A </div>



TUPC GYMNASIUM
GROUND FLOOR PLAN

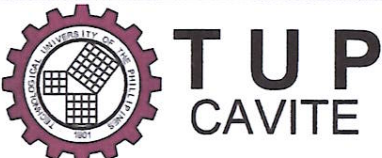

	PROJECT TITLE:	PROPOSED BY:	APPROVED BY:	DESIGNED BY:	SHEET NO.
	PROPOSED TUPC GYMNASIUM	ENGR. BRYLLE EPHRAEM Q. NAVARRO IDO, CHAIRPERSON	ENGR. ALEXANDER E. MAG-ISA, Ph.D.,PME CAMPUS DIRECTOR	IDO - CAVITE CAD BY:	5 A

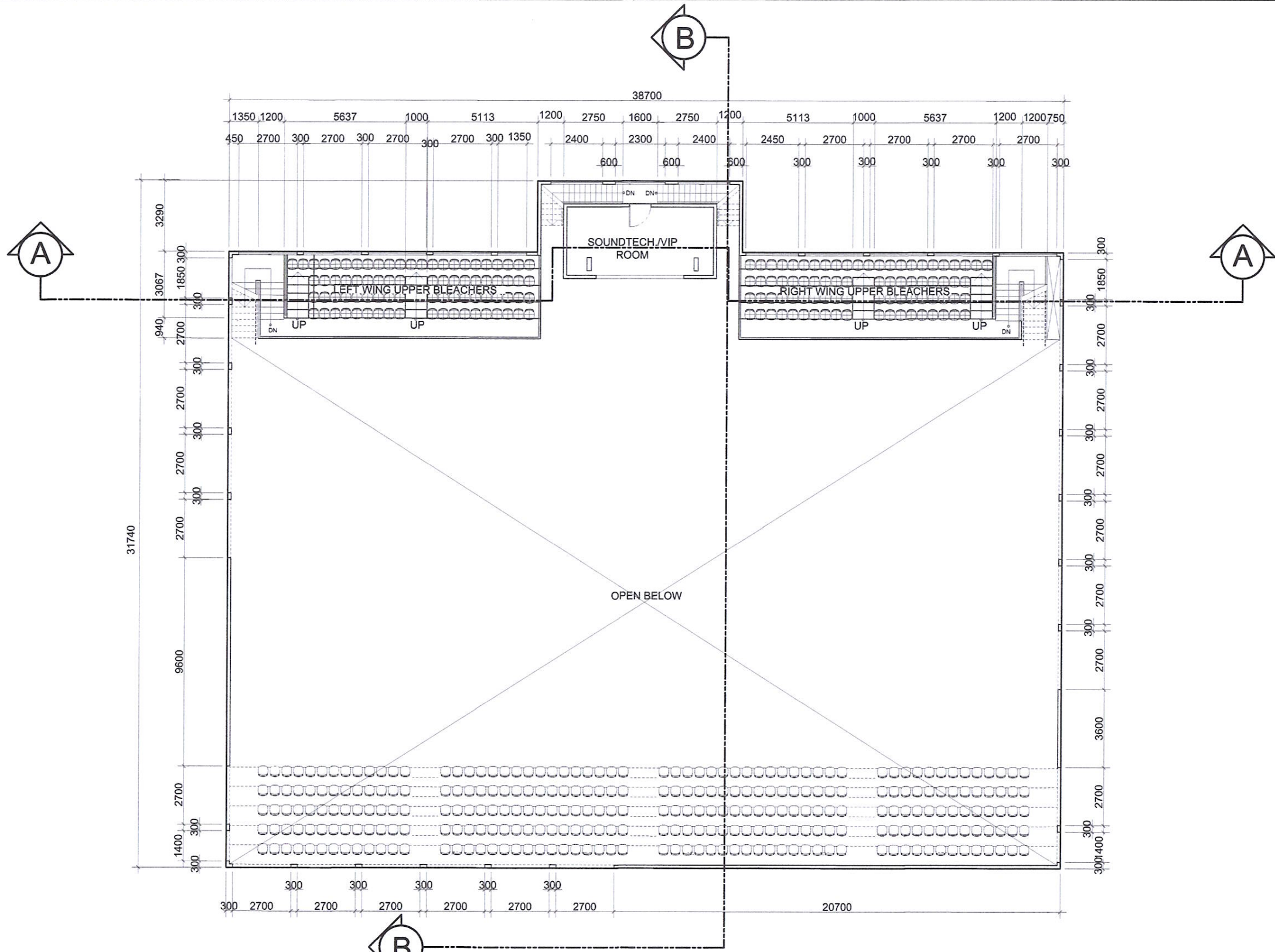

TUPC GYMNASIUM
SECOND FLOOR PLAN

SCALE 1:150

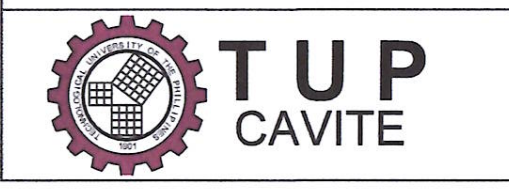

PROJECT TITLE:	PROPOSED BY:	APPROVED BY:	DESIGNED BY:	SHEET NO.
PROPOSED TUPC GYMNASIUM	ENGR. BRYLLE EPHRAEM Q. NAVARRO IDO, CHAIRPERSON	ENGR. ALEXANDER E. MAG-ISA, Ph.D.,PME CAMPUS DIRECTOR	IDO - CAVITE CAD BY:	6 A

TOP OF APEX
ELEV. + 10.86 MTS.

3800

TOP OF ROOF BEAM
ELEV. + 10.56 MTS.

3730

AWNING WINDOW

FIN. F. L. R. (2ND FLR)
ELEV. + 3.20 MTS

370

CEILING LINE (GRD. FLR.)
ELEV. + 2.65 MTS

3020

ELEV. + 0.20 MTS
N. G. L. 0.00

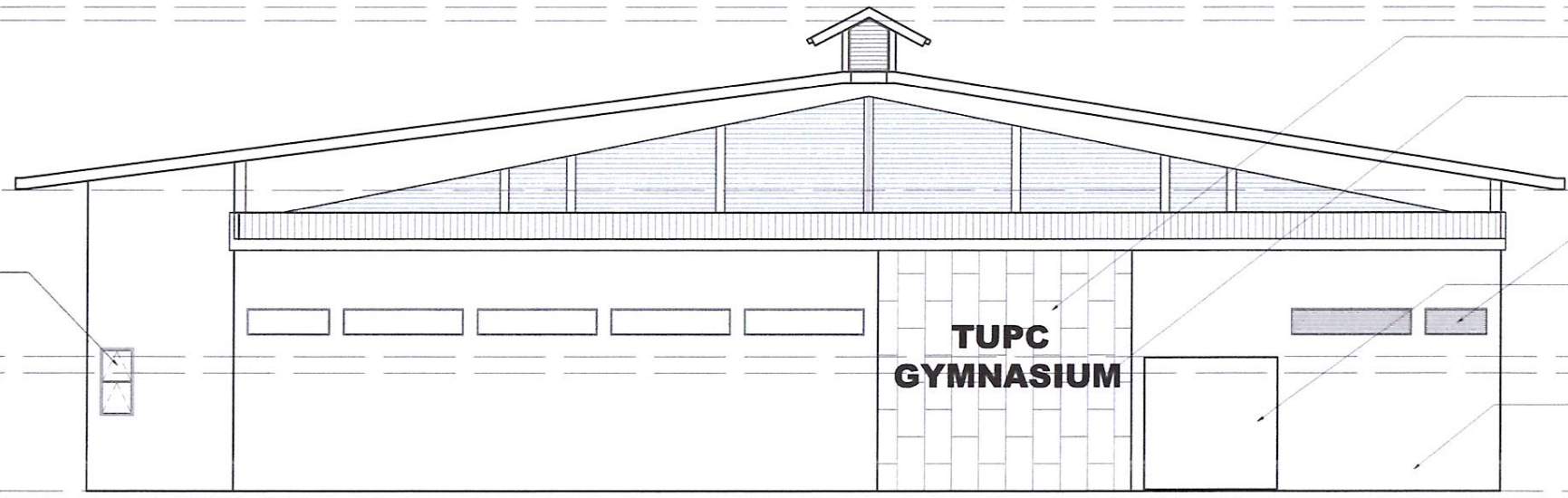

ALUMINUM
COMPOSITE PANEL

STAINLESS LETTERING
HEIGHT : 0.5 M
WIDTH : 0.3 M

2 1/2" x 3/8" FLAT
BAR LOUVER

FRAMED TEMPERED
GLASS DOOR

PAINT ON
CONCRETE FINISH

TUPC GYMNASIUM
FRONT ELEVATION
SCALE 1:150

TOP OF APEX
ELEV. + 10.86 MTS.

3800

TOP OF ROOF BEAM
ELEV. + 10.56 MTS.

3730

AWNING WINDOW

FIN. F. L. R. (2ND FLR)
ELEV. + 3.20 MTS

370

CEILING LINE (GRD. FLR.)
ELEV. + 2.65 MTS

3020

ELEV. + 0.20 MTS
N. G. L. 0.00

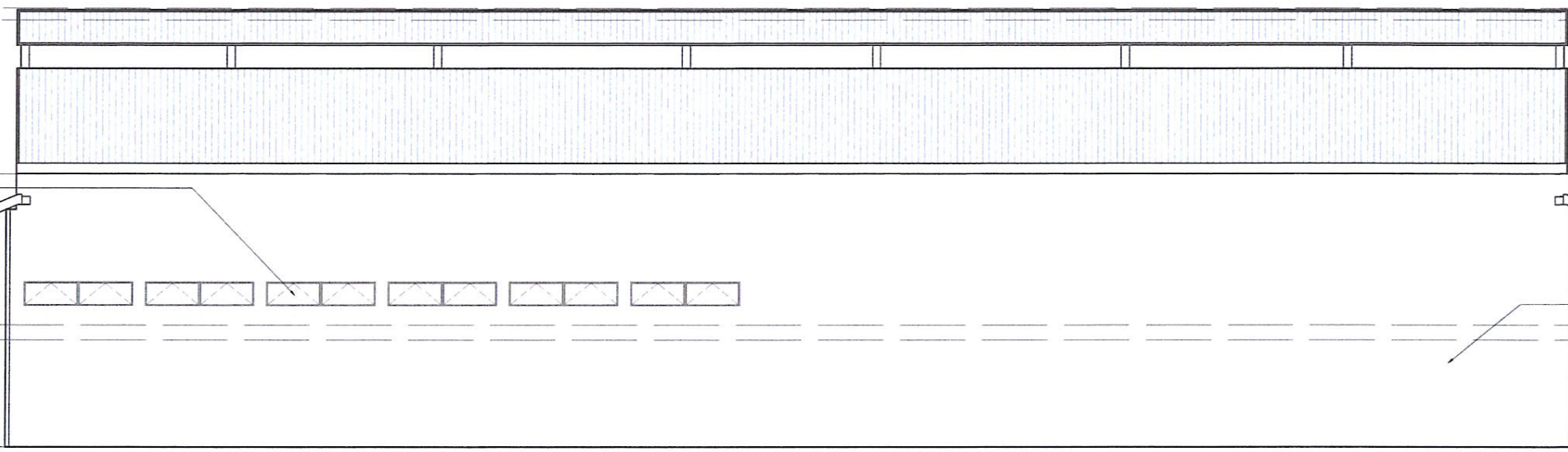

PAINT ON
CONCRETE
FINISH

TUPC GYMNASIUM
RIGHT SIDE ELEVATION
SCALE 1:150

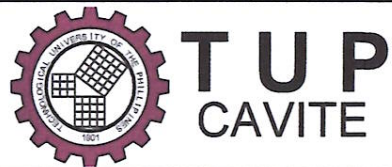

PROJECT TITLE: PROPOSED TUPC GYMNASIUM	PROPOSED BY: ENGR. BRYLLE EPHRAIEM Q. NAVARRO IDO, CHAIRPERSON	APPROVED BY: ENGR. ALEXANDER E. MAG-ISA, Ph.D.,PME CAMPUS DIRECTOR	DESIGNED BY: IDO - CAVITE	SHEET NO. 7 A
			CAD BY:	

TOP OF APEX
ELEV. + 10.86 MTS.

300

3800

TOP OF ROOF BEAM
ELEV. + 10.56 MTS.

3800

FIN. F. L. R. (2ND FLR)
ELEV. + 3.20 MTS

370

CEILING LINE
(GRD. FLR.)
ELEV. + 2.65 MTS

3020

ELEV. + 0.20 MTS
N. G. L. 0.00

200

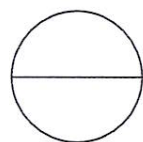

TUPC GYMNASIUM
LEFT SIDE ELEVATION
SCALE 1:150

TOP OF APEX
ELEV. + 10.86 MTS.

300

3800

TOP OF ROOF BEAM
ELEV. + 10.56 MTS.

3730

FIN. F. L. R. (2ND FLR)
ELEV. + 3.20 MTS

370

CEILING LINE (GRD. FLR.)
ELEV. + 2.65 MTS

3020

ELEV. + 0.20 MTS
N. G. L. 0.00

200

FRAMED TEMPERED
GLASS DOOR

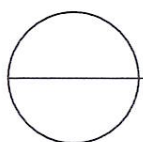
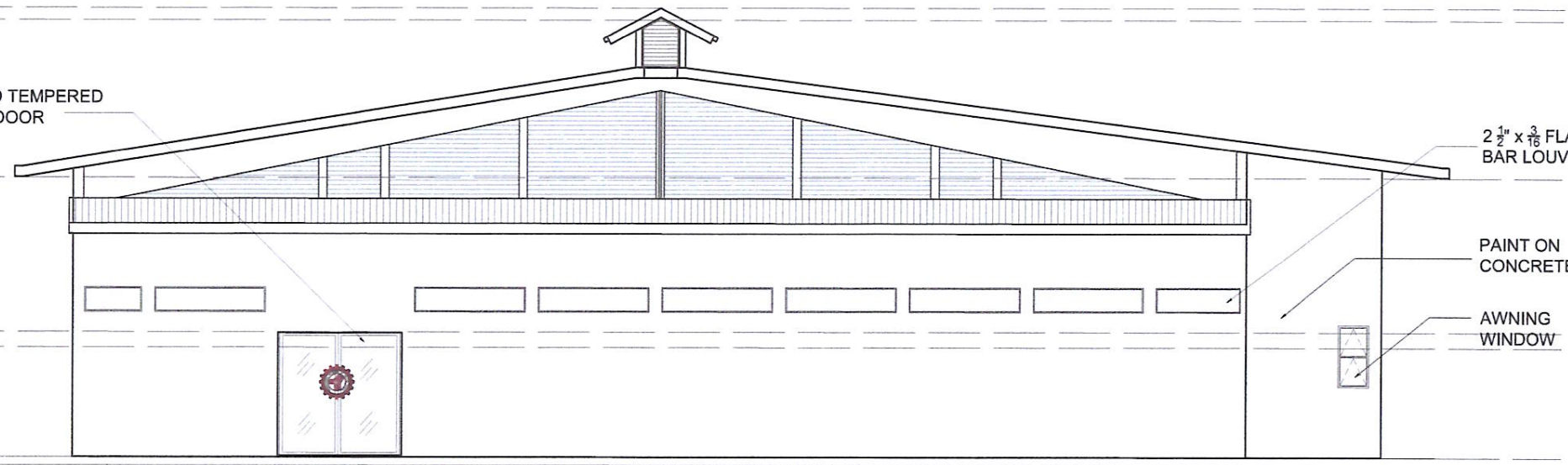

TUPC GYMNASIUM
REAR ELEVATION
SCALE 1:150

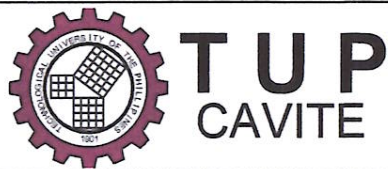

PROJECT TITLE:	PROPOSED BY:	APPROVED BY:	DESIGNED BY:	SHEET NO.
PROPOSED TUPC GYMNASIUM	ENGR. BRYLLE EPHRAIEM Q. NAVARRO IDO, CHAIRPERSON	ENGR. ALEXANDER E. MAG-ISA, Ph.D.,PME CAMPUS DIRECTOR	IDO - CAVITE	8 A
			CAD BY:	



PROGRAM OF WORKS FOR THE RENOVATION OF GYMNASIUM AT TUP CAVITE CAMPUS



**TECHNOLOGICAL UNIVERSITY OF THE PHILIPPINES
CAVITE CAMPUS**

Carlos Q. Trinidad Ave., Salawag, Dasmariñas City, Cavite

**PROGRAM OF WORKS FOR THE PROPOSED
RENOVATION OF TUPC GYMNASIUM**

SCOPE OF WORKS

I. Clearing/Excavation/Mobilization/Demobilization

Excavation of footing, Wall footing, Wastewater and
Drainage, Site Clearing, , testing of materials

MATERIALS:

DESCRIPTION	QTY UNIT	UNIT PRICE	
	1 lot	MATERIAL COST	P
		LABOR COST	P
		DIRECT COST	P

II. CONCRETING/MASONRY WORKS

Concreting of footing, column, beams, wall footing, shear wall and Slab,
CHB laying for masonry walls

Plastering and finishing of masonry and concrete surfaces

Tiles

MATERIALS:

DESCRIPTION	QTY	UNIT PRICE	
	1	LOT	
		MATERIAL COST	P
		LABOR COST	
		DIRECT COST	P

III. REINFORCEMENT WORKS

Reinforcement of footing, column,beams, wall footing, stairs and Slab,
Reinforcement on various masonry and concrete structure

MATERIALS:

DESCRIPTION	QTY	UNIT PRICE	
	1	LOT	
		MATERIAL COST	P
		LABOR COST	
		DIRECT COST	P

IV. FORMS/SCAFFOLDING WORKS

Scaffolding and staging on all masonry works, plastering, concreting, carpentry and roofing works
Installation of forms on all concreting works

MATERIALS:

DESCRIPTION	QTY	UNIT PRICE	
	1	LOT	
		MATERIAL COST	P
		LABOR COST	
		DIRECT COST	P

V. TELECOMMUNICATION

Fabrication and installation of Sound system
Installation of cctvs
Installation of score boards

MATERIALS:

DESCRIPTION	QTY	UNIT PRICE	
	1	LOT	
	1	MATERIAL COST	P
		LABOR COST	
		DIRECT COST	P

VI. FENESTRATION WORKS

Installation of door and windows
Installation of door panels and movable partitions glass partition

MATERIALS:

DESCRIPTION	QTY	UNIT PRICE	
	1	LOT	
		MATERIAL COST	P
		LABOR COST	
		DIRECT COST	P

VII. CEILING WORKS/CARPENTRY/CABINETRY WORKS

Fabrication & installation of steel T-runner & hanger for ceiling frames
Installation of fiber cement ceiling boards and fascia boards, Cabinets and other related wood works dry walling

MATERIALS:

DESCRIPTION	QTY	UNIT PRICE	
	1	LOT	
		MATERIAL COST	P
		LABOR COST	
		DIRECT COST	P

VIII. PAINTING WORKS

Painting of interior and exterior wall including ceiling and all parts of the building

MATERIALS:

DESCRIPTION	QTY	UNIT PRICE	
	1	LOT	
		MATERIAL COST	P
		LABOR COST	
		DIRECT COST	P

IX. PLUMBING WORKS

Installation of water supply and sewerage system
Installation of water closets and other fixtures
Installation of septic tank

MATERIALS:

DESCRIPTION	QTY	UNIT PRICE	
	1	LOT	
		MATERIAL COST	P
		LABOR COST	
		DIRECT COST	P

X. ELECTRICAL WORKS

Installation of panel board & breakers, and connection to main power supply
Installation of lighting and power lines including fixtures & raceways

MATERIALS:

DESCRIPTION	QTY	UNIT PRICE	
	1	LOT	
		MATERIAL COST	P
		LABOR COST	
		DIRECT COST	P

XI. MECHANICAL WORKS

Installation of aircon and ducting
Installation of other mechanical works
Fabrication and installation steel railings, hand rails and the like
Roofing materials

MATERIALS:

DESCRIPTION	QTY	UNIT PRICE	
	1	LOT	
		MATERIAL COST	P
		LABOR COST	
		DIRECT COST	P

XII. FINISHING WORKS

Installation of brise soleil wood plastic composite
and aluminum composite curtain walls
Aluminum Cladding for façade

	1	LOT	
		MATERIAL COST	P
		LABOR COST	
		DIRECT COST	P

XIII. MISCELLANEOUS

Basketball court flooring, basketball goal, bleachers and others, Industrial fan

1	LOT	
	MATERIAL COST	P
	LABOR COST	
	DIRECT COST	P
TOTAL DIRECT COST		P
	OVERHEAD/CONTIGENCY/MISC	
	CONTRACTOR'S PROFIT	
	EVAT (12%)	
	TOTAL ESTIMATED PROJECT COST	P

PREPARED BY:

Engr. Brylle Eonraiem Q. Navarro
IDO-Chairperson

APPROVED BY:

Engr. Alexander E. Mag-Isa, Ph.D., PME
Campus Director



ACQUISITION OF ELECTRIC PUV UNDER GREEN PUBLIC PROCUREMENT FOR SUSTAINABLE AND EQUITABLE CAMPUS MOBILITY



REGIONAL DEVELOPMENT COUNCIL NATIONAL CAPITAL REGION (RDC-NCR)

“Where Metro Manila goes, so the country goes”

FORMULATION OF THE REGIONAL DEVELOPMENT INVESTMENT PROGRAM FOR THE NATIONAL CAPITAL REGION (RDIP-NCR) 2023-2028

IMPLEMENTING AGENCY: TECHNOLOGICAL UNIVERSITY OF THE PHILIPPINES CAVITE CAMPUS

CO-IMPLEMENTING AGENCY: NA

FOCAL PERSON: ATTY. DANILO M. ABAYON/OIC-Campus Director

CONTACT DETAILS: Carlos Q. Trinidad Avenue, Salawag, Dasmariñas City, Cavite/ (046) 416-4920

PROJECT PROFILE	
A. GENERAL INFORMATION	
TITLE	Acquisition of 1 Unit Electric PUV under Green Public Procurement for Sustainable and Equitable Campus Mobility
PROGRAM¹ OR PROJECT²	<input type="checkbox"/> Program <i>Is it a regular program?³</i> <input type="checkbox"/> Yes ✓ <input type="checkbox"/> No <input checked="" type="checkbox"/> Project <i>Is this part/included in your Central Office's Public Investment Program (PIP)?</i> <input checked="" type="checkbox"/> Yes <input type="checkbox"/> No
STATUS	<input type="checkbox"/> Ongoing ⁴ <input checked="" type="checkbox"/> Proposed <input type="checkbox"/> Pipeline <input type="checkbox"/> Completed
DESCRIPTION	This project focuses on the strategic Green Procurement of one (1) unit of the Electric PUV Class 2 Battery Electric Vehicle (BEV) to launch a pilot low-emission, high-capacity transport service. The procurement aligns with the PDP's strategy to strengthen green public procurement and increase the adoption of e-vehicles to reduce transport costs and GHG emissions. The components include the BEV unit (featuring specialized energy-efficient air conditioning and a regenerative braking system) and the necessary charging infrastructure. The definite purpose is to transition the campus fleet towards low-carbon technology and establish an affordable, reliable, and inclusive transport service for students and employees for official business.
OBJECTIVES	This initiative addresses the dual development gap of significant transport-related greenhouse gas (GHG) emissions and the high financial burden of commuting, which contributes to student dropout rates. By acquiring this zero-emission Electric PUV through green procurement principles, the project enables the low carbon economy transition and advances climate action,

¹ A program is a group of activities and projects that contribute to a common particular outcome. A program should have the following: a) unique expected results or outcomes; b) clear target population or client group external to the agency; c) defined method of intervention to achieve the desired result; and d) a clear management structure that defines accountabilities.

² A project is a special undertaking carried out within a definite timeframe and intended to result in some pre-determined measure of goods and services.

³ Refers to a program being implemented on a regular basis. For regular programs, only the investment targets covering 2023-2028 shall be submitted.

⁴ Ongoing P/Ps are considered ongoing if they satisfy any of the following: (a) if locally funded - upon issuance of notice to proceed; (b) if Official Development Assistance (ODA)-assisted - upon effectivity of loan or grant agreement; and (c) if PPP or Joint Venture (JV)- upon signing of concession/JV agreement including unsolicited PPP P/Ps.

PROJECT PROFILE		
	aligning with the national commitment to green economic transformation. Concurrently, the service provides an affordable and inclusive mode of transport, thereby strengthening the protection of student capabilities and ensuring access to high-quality lifelong learning opportunities.	
COMPONENTS	The core component is of one (1) high-capacity PUV Class 2 Battery Electric Vehicle (BEV), specifically chosen for its energy efficiency, low maintenance costs, and high passenger capacity (22+9). An essential accompanying component is the Installation of Required Charging Infrastructure to ensure the continuous and optimal operational viability of the single BEV unit, supported by its 70kWh battery and rapid charging capability. The project includes the Implementation of an Equitable Fare and Route Service Plan designed to reduce commuting costs for students and promote inclusive access across the campus community. Finally, Performance Monitoring and Reporting mechanisms will be established to track the reduction in transportation-related GHG emissions and assess the fleet's positive impact on student retention and institutional climate action compliance.	
LOCATION/SCOPE	Carlos Q. Trinidad Avenue, Salawag, Dasmariñas City, Cavite	
IMPLEMENTATION PERIOD	Start of implementation: 1 st quarter of 2026 End of implementation: 4 th quarter of 2026	
EXPECTED OUTPUTS	The immediate output is the deployment of a fully operational, 1-unit zero-emission Electric PUV campus service fleet, which will result in a measurable reduction in the university's transportation-related greenhouse gas emissions and strengthened institutional capacity for climate action. This new service is expected to enhance student equity and access to higher education by providing an affordable and reliable commuting option, thus directly mitigating dropout risks linked to financial constraints.	
LEVEL OF GAD RESPONSIVENESS⁵	<input type="checkbox"/> GAD is invisible in the program/project <input type="checkbox"/> Program/Project has promising GAD prospects <input type="checkbox"/> Program/Project is gender-sensitive <input checked="" type="checkbox"/> Program/Project is gender-responsive	
B. PROJECT FINANCING		
FINANCING SOURCE	<input checked="" type="checkbox"/> NG-Local <input type="checkbox"/> ODA Loan <input type="checkbox"/> ODA Grant <input type="checkbox"/> Internally-generated fund (for GOCCs/GFIs) <input type="checkbox"/> Private Sector <input type="checkbox"/> Others: Please specify, _____	
YEAR	Amount <i>(separate columns per funding source, if applicable)</i>	
	GAA/Internal Funds	Other Funding Source/s
2023	-	-
2024	-	-
2025	-	-
2026	-	-
2027	3,500,000	-
2028	-	-
Continuing Years	-	-
Total (2023-2028)	3,500,000	-
TOTAL PROJECT COST	3,500,000	-

⁵ Identify the Level of GAD Responsiveness of the program/project based on the score of the program/project using the appropriate Gender and Development (GAD) checklist (<https://neda.gov.ph/gender-and-development/>).

PROJECT PROFILE	
C. TYPOLOGY	
TYPE OF P/P	<input type="checkbox"/> Major Capital Investment Program and Project <input type="checkbox"/> Technical Assistance Program/Project (such as Research and Development, Institutional Development, Human Resource Capacity Building, or System/Process Improvement PAPs) <i>Is the Technical Assistance Program/Project considered a Research and Development Program/Project?</i> <input type="checkbox"/> Yes <input type="checkbox"/> No <input type="checkbox"/> Relending Program/Project of GFIs to LGUs and Target Beneficiary <input checked="" type="checkbox"/> Government Facilities used as an office, housing, and other technical purposes
D. READINESS	
PROJECT PREPARATION DOCUMENT ACCOMPLISHED	<input checked="" type="checkbox"/> Feasibility Study F/S Cost (in exact PHP amount). _____ <i>Status:</i> <input type="checkbox"/> Completed <input type="checkbox"/> -Ongoing. Expected Completion Date: February 2026 <input type="checkbox"/> For Preparation. Start Date: _____ <input type="checkbox"/> Business Case <input type="checkbox"/> Project Proposal <input checked="" type="checkbox"/> Concept Note <input type="checkbox"/> Project Idea <input type="checkbox"/> Others: Brochure
APPROVALS	<input type="checkbox"/> RDC-NCR Approval <i>Date of Approval:</i> _____ <input type="checkbox"/> ICC/NEDA Board Approval not required Approval/s Secured: _____ Date of Approval: _____ Approval/s Required: _____ Target Date of Approval: _____ <input type="checkbox"/> ICC/NEDA Board Approval required <i>Status of ICC/NEDA Board Approval?</i> <input type="checkbox"/> Yet to be submitted to NEDA Secretariat Target Date of Submission: _____ <input type="checkbox"/> Under the NEDA Secretariat Review Date of Submission to NEDA Secretariat: _____ <input type="checkbox"/> ICC-TB Endorsed Date of Endorsement: _____ <input type="checkbox"/> ICC-CC Approved Date of Approval: _____ <input type="checkbox"/> NEDA Board Confirmed Date of Approval: _____

PROJECT PROFILE			
LEVEL OF READINESS	<input type="checkbox"/> Level 1: With the approval of appropriate authority ⁶ but not yet ongoing <input type="checkbox"/> Level 2: Project preparation document completed; For the approval of appropriate approving body in 2022 or 2023 and for inclusion in the NEP for FY 2023 <input checked="" type="checkbox"/> Level 3: Project preparation document currently being prepared and to be completed in 2023; for approval in 2024 and for inclusion in the NEP for FY 2025		
FOR ONGOING P/Ps			
PHYSICAL ACCOMPLISHMENT	NA		
FINANCIAL ACCOMPLISHMENT			
Year	Amount Included/for Inclusion in the NEP	Amount Allocated in the Budget/GAA	Actual Amount Disbursed
2023	-	-	-
2024	-	-	-
2025	-	-	-
2026	-	-	-
2027	3,500,000	-	-
2028	-	-	-
E. PROJECT/PROGRAM VIABILITY			
Project benefits	<p><i>The project significantly reduces transportation-related greenhouse gas emissions within the campus.</i></p> <p><i>It provides students and employees with an affordable and dependable mobility service, lowering overall commuting expenses.</i></p> <p><i>The Electric PUV enhances inclusive access to education by supporting students who face financial constraints.</i></p> <p><i>Maintenance and operating costs are minimized through energy-efficient technology and simplified fleet upkeep.</i></p> <p><i>It strengthens the institution's capacity to comply with national climate mitigation commitments and sustainable procurement policies.</i></p> <p><i>The project serves as a scalable model for future expansion of clean transport solutions in the university.</i></p>		

Prepared by:



DARIUS L. FAJARDO

Planning Officer
March 02, 2026

Approved by:

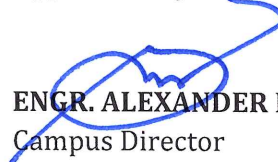

ENGR. ALEXANDER E. MAG-ISA

Campus Director
March 02, 2026

(as of June 26, 2023)

⁶Please attach a copy of approval



Justification for the Acquisition of One (1) Unit Electric PUV under Green Public Procurement for Sustainable and Equitable Campus Mobility

The Acquisition of One (1) Unit Electric PUV under Green Public Procurement for Sustainable and Equitable Campus Mobility is justified as a strategic investment that responds to the urgent need to decarbonize transport services within the university. Transportation remains a major source of greenhouse gas emissions, and introducing a zero-emission mobility option directly contributes to the institution's transition toward a low-carbon campus. Through green public procurement, the university demonstrates leadership in adopting climate-aligned infrastructure, enhancing its compliance with national climate mandates and its role as a model SUC in climate action.

The Electric PUV offers a campus-level solution that can meaningfully reduce transport-related financial burdens experienced by students and employees. Transportation costs are consistently reported as a contributor to student dropout cases, and an affordable, reliable mobility service ensures that financial constraints do not hinder access to education. By providing a safe and accessible campus transport alternative, the university strengthens academic continuity, inclusiveness, and student well-being.

This initiative also integrates operational efficiency as a core element of sustainable mobility. The technology features—such as regenerative braking, high-capacity seating, and energy-efficient systems—translate into lower operating and maintenance costs over the vehicle's lifecycle. These advantages reduce long-term budgetary pressures while improving the efficiency of institutional transport operations. The introduction of charging infrastructure further ensures energy-secure operations that are aligned with long-term sustainability goals.

In addition, the project advances the development of institutional capacity for greenhouse gas (GHG) emission reduction efforts. Deployment of the Electric PUV allows TUP-Cavite to generate measurable GHG inventory baselines linked to its transport sector, improving the accuracy of climate reporting and monitoring systems. This strengthens alignment with national plans for carbon reduction while concretely demonstrating the university's contribution to climate commitments in the education sector.

The project also supports the broader government directive on green public procurement, specifically prioritizing technologies that reduce environmental impacts across the service delivery chain. As the university increasingly participates in national climate-related budgeting exercises, the adoption of an Electric PUV becomes an enabling action for compliant and proactive institutional governance. It reinforces the institution's readiness to utilize climate-tagged expenditures that generate direct environmental and social benefits.

Finally, the Electric PUV serves as a pilot that can pave the way for future replication and scaling. As campuses grow, transport demand will continue to increase, and this project establishes the foundation for a fleet transition toward clean mobility. It delivers practical, evidence-based insights on performance, ridership, and emission reduction, which will guide future feasibility and expansion studies. Through this pilot initiative, TUP-Cavite affirms its commitment to sustainability innovations that balance environmental stewardship, social equity, and operational responsiveness.

LexSWITCH EV6 PUV



(CLASS 2)

● Model Name: Lex-HS6606 ●



Dimension (mm):

5995*1900*2800



LEFT-HAND DRIVE



Vehicle Type:

Battery Electric Vehicle (BEV)

Gross Vehicle Weight:

4,800 kg

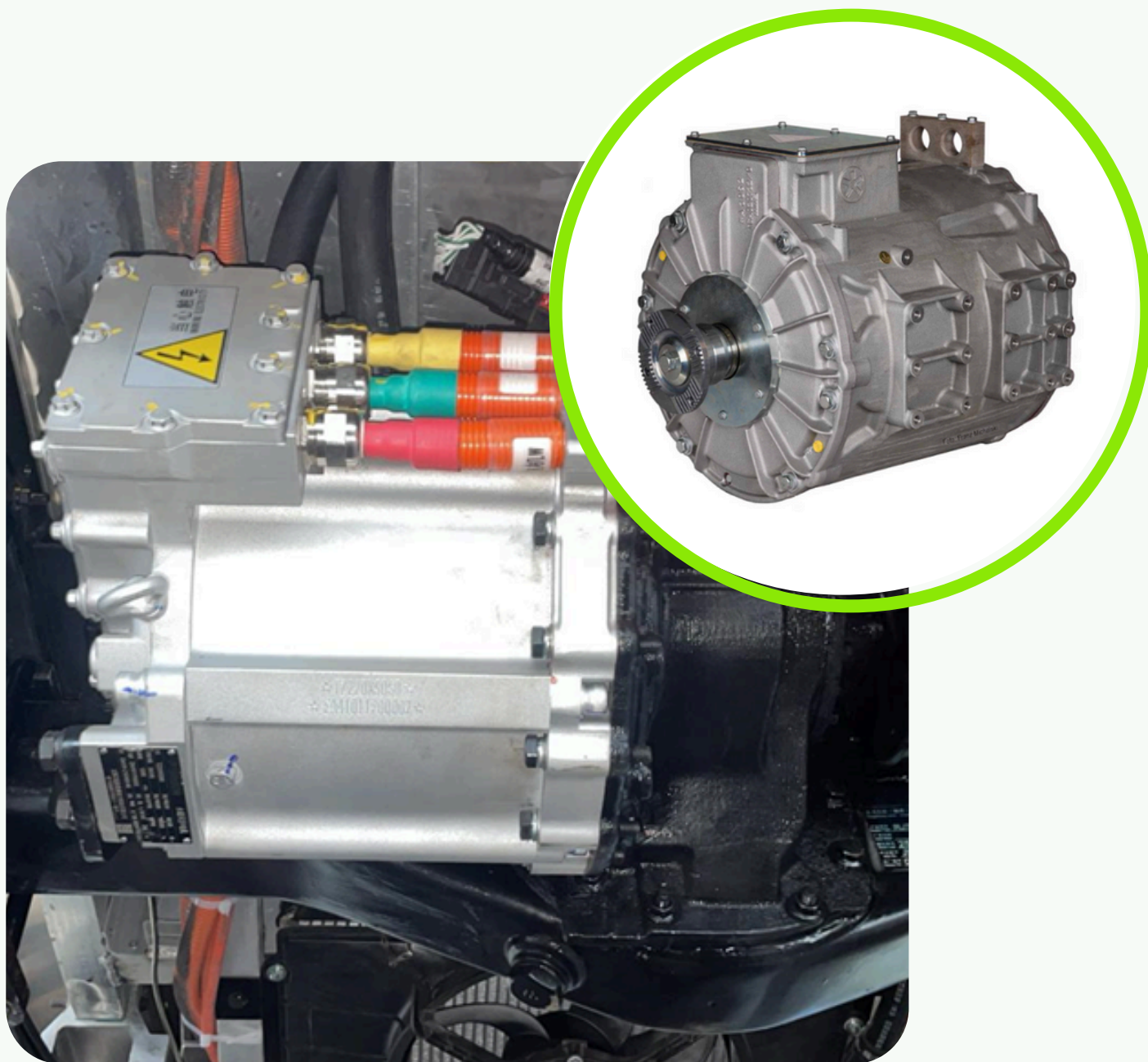

Inovance TZ210 electric motor has a power range of 60-120kW, operating at the torque between 290-480V. Besides that, it **can travel up to 200km** with AirCon ON and in a full load passengers condition

Leaf Spring Suspension

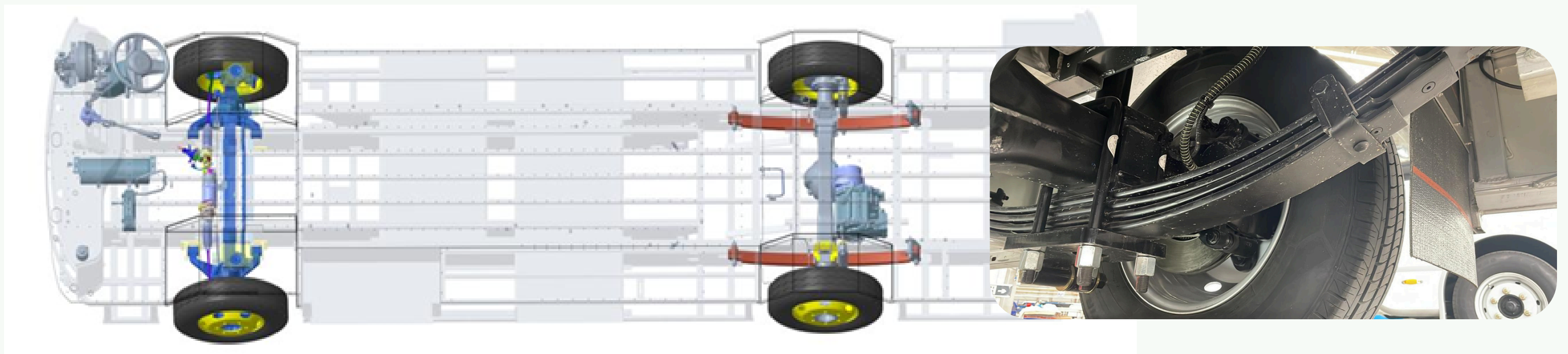

Front Axle:

2.0 ton axle with Disc Brake



Rear Axle:

2.8 ton axle with Disc Brake



Tires:

225/75R16C



Hand Brake:

Electronic type, Cable assists



Brake System:

Hydraulic Brake (Regenerative Braking)

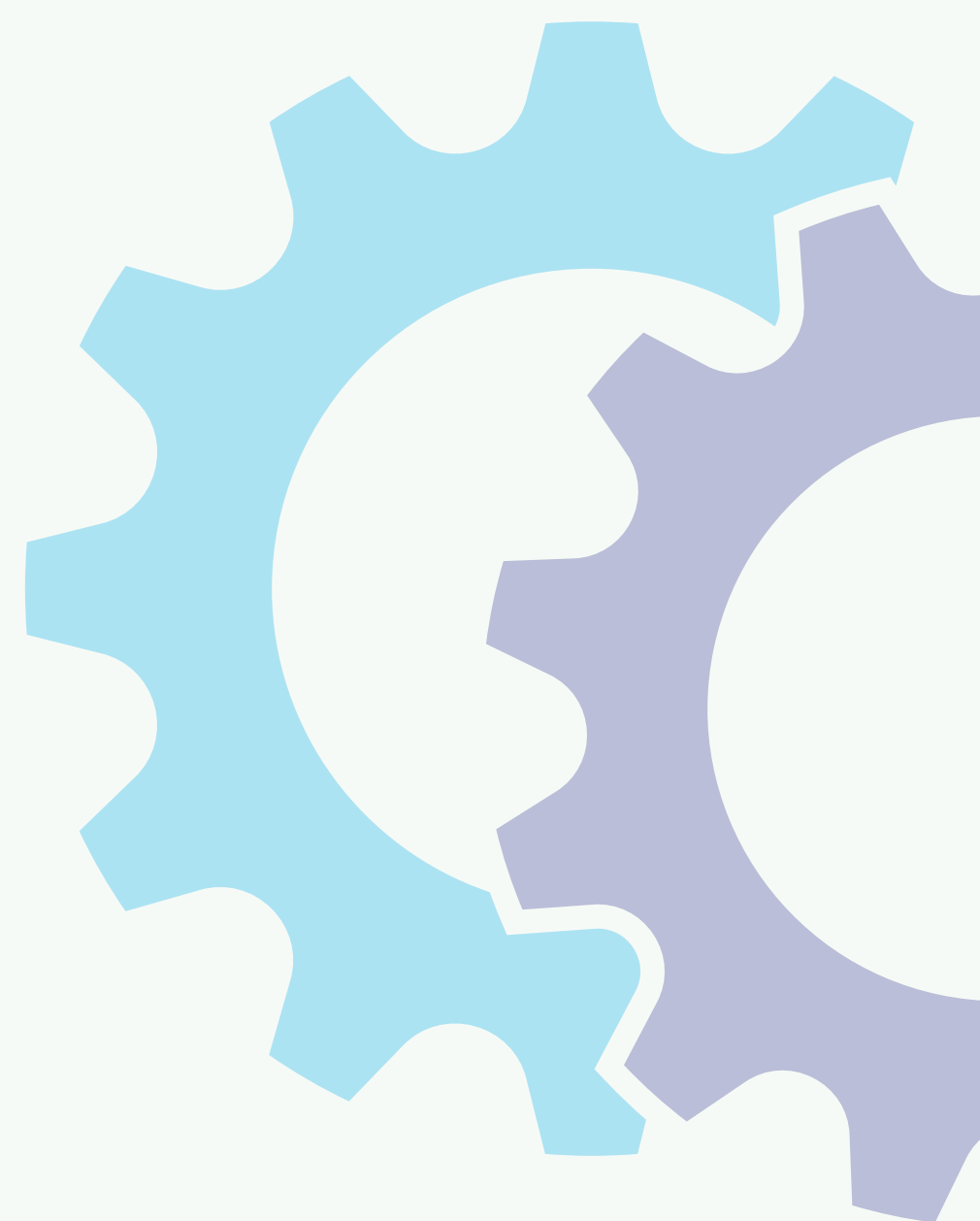



With a full aluminum monocoque body frame, we achieve a **40% reduction in weight** and **corrosion-free durability**. Our warranty extends up to 10 years, reflecting our high confidence in the material aspect.

With Weight Optimization



Consume less energy



Improved maneuverability



Incur lower maintenance costs



Designed in **Singapore**



Assembled in our plant in **China**

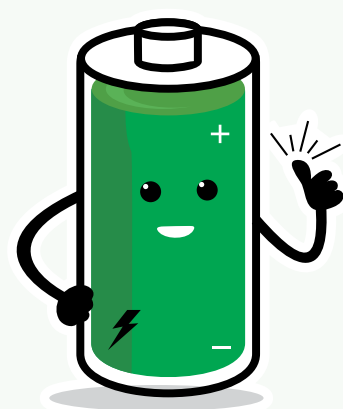

70.19kWh

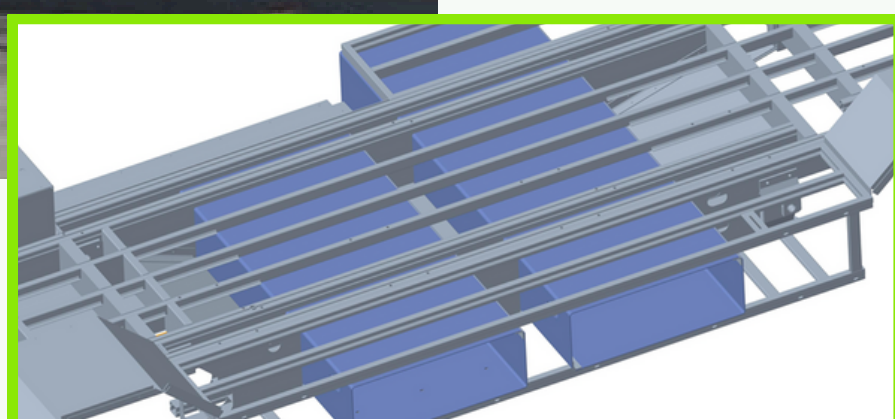

The vehicle delivers outstanding performance using a **Lithium-Ion Battery**, featuring a **co-owned developed BMS and ECU**. It provides an optimal range with a **70kWh battery capacity** and includes a **7kWh slow charger onboard** as a backup. The **fast charging** capability allows the battery to **reach 100% in < 90 minutes**.



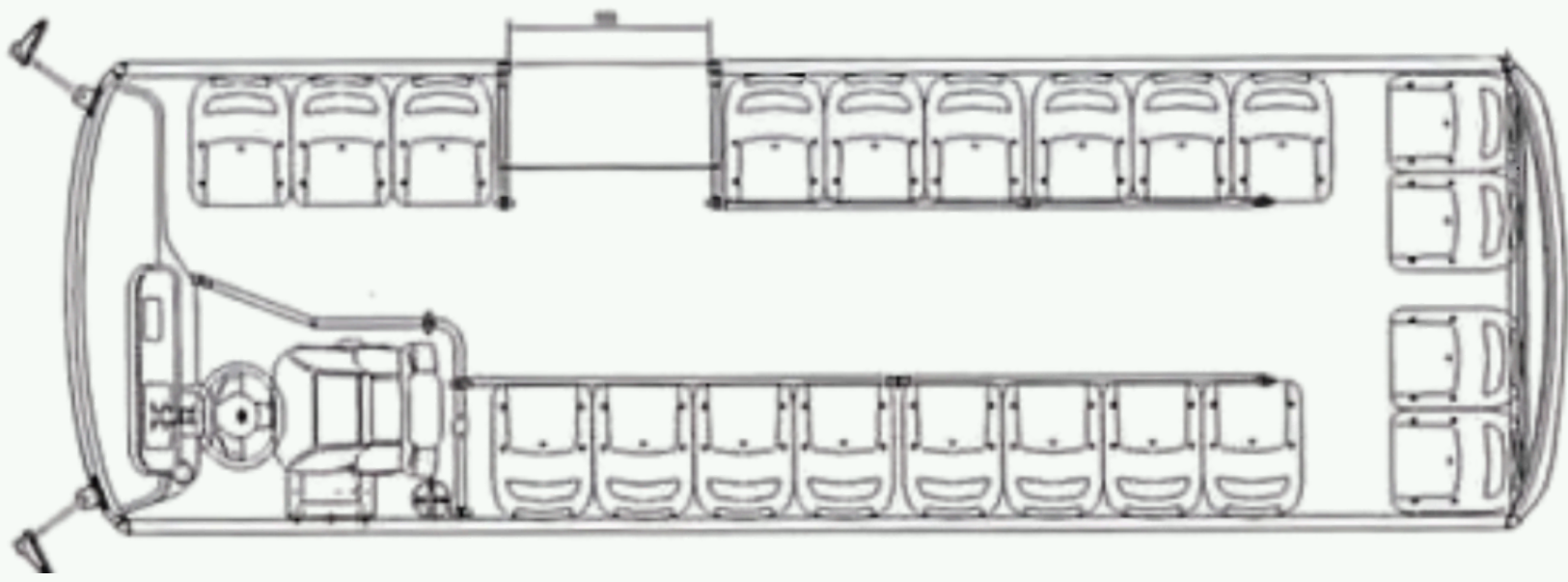

22+9

Customizing the seat arrangement by maximizing the seating capacity with 9 standee to fulfil customer's needs.



Revolutionize your fleet with LexSWITCH AFCS and Monitoring System



LexSWITCH Lex-HS6606 PUV Class 2 also equipped with NTC Aircon which the size is smaller, excellent noise reduction and consumes significantly less power, enhancing overall energy efficiency and sustainability.



The electric folding door of the bus is designed to provide convenient access for passengers while ensuring safety and efficiency during boarding and alighting.

Certificate of Compliance (COC)

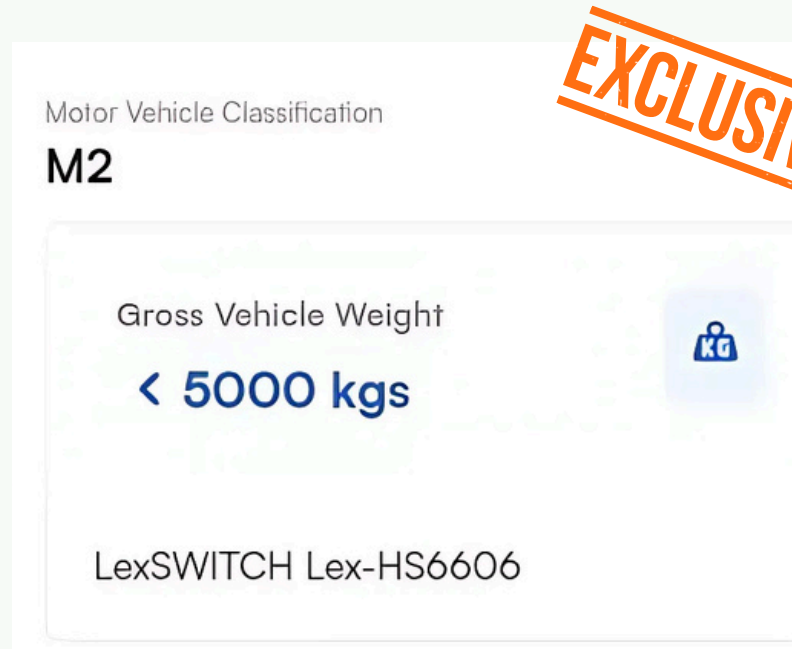
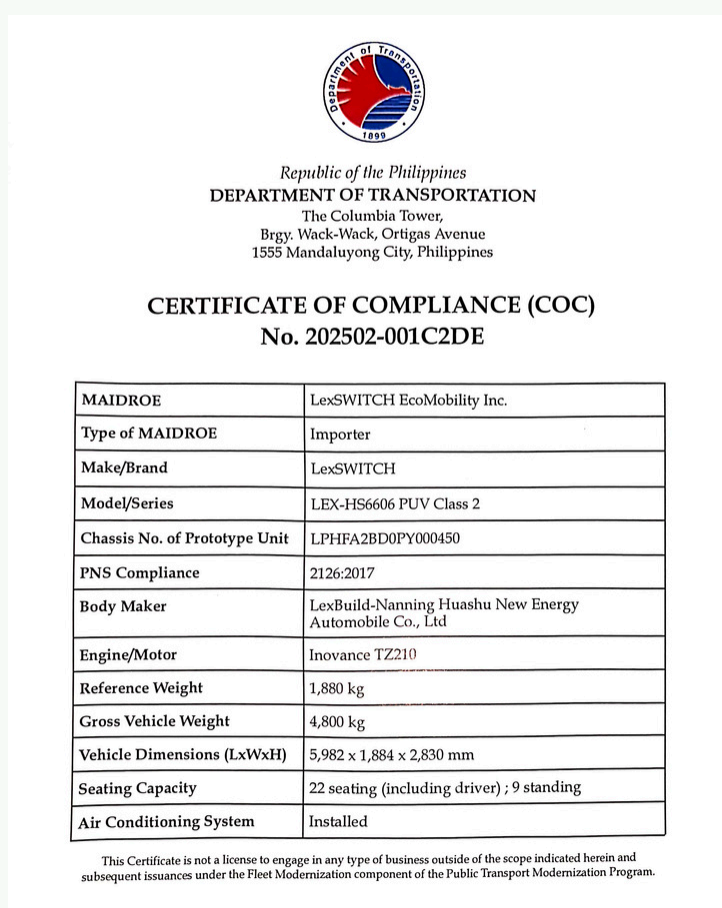

EXCLUSIVE

Tested, Trusted and Revenue-Ready - LexSWITCH it

Officially released on February, 2025 at evindustry.ph



LexSWITCH EcoMobility Inc.

Address: **24th Floor Philippine Stock Exchange Tower BGC Taguig City**

Official Sales Team Email: sales@LexSWITCH.com.sg



Contact Details

Hezekiah Alis

(Corporate Secretary)

✉ hezekiah@LexSWITCH.com.sg

☎ +63 956 537 4938

Jeffrey Michael A. Tumlos

Marketing Manager (Region VI)

✉ jeftumlos@LexSWITCH.com.sg

☎ +63 0960 525 9925

Justin Karl B. Bercades

Sales Manager (Region VI)

✉ justin@LexSWITCH.com.sg

☎ +63 999 981 8010